



LIVING ON THE EDGE

A Programme Resource for Venture Scout Units

Compiled by Colm Kavanagh

LIVING ON THE EDGE

LIVING ON THE EDGE



A Programme Resource for
Venture Scout Units

page 1

This handbook has been developed to support Venture Scout Units and teenagers who wish to do something more than 'hanging about' on street corners.

Concepts and original programme ideas are supported by

Magazine articles from Scout Leader and
No Limits magazines by Colm Kavanagh

Relevant material from The Scouting Trail by Colm Kavanagh

We also wish to acknowledge

Scouting Magazine UK for archive material which was used as the basis of some of the material presented.

Boy Scouts of America COPE Programme for Low Level Rope Courses illustrations

Christian Aid UK for 'The World Trading Game' and 'Paper Bag Game' exercises.

Advanced Paper Plane Construction by Morris Campbell for ideas on paper plane construction

Various websites for material (search Google)

Home made stoves

Mousetrap cars

Paper planes



We wish to also acknowledge the support received from the Department of Education and Science - Youth Affairs section under the National Development Plan 2002-2006



The Association would also like to acknowledge the support it received for this project from the Irish Youth Foundation

Material and concepts in this handbook are designed to be used by young people of teenage years and can be freely used by anyone who is interested in the development of young people - with suitable acknowledgement to source.

The activities suggested are best undertaken as a member of a youth organisation where proper adult supervision, safety and insurance considerations are available.

Index

Working with Groups	005	The Egg Challenge	067
The Island - exploring leadership styles	008	Challenge Games	068
Getting it together	011	Scout Engineering	070
Rules and Regs sample	013	Wide Games	073
Promise and Law	015	Rafting	078
Yearly Programme Plan	018	Street Theatre	080
Year Activity Plan	019	Orienteering	082
Outline plan for a first years programme (January to December)	020	The Problem of Survival	084
Ideas for your Venture Programme	032	World Trade Game	087
Creative Thinking	039	Why expeditions	090
Lateral Thinking	041	Some expeditions to explore	092
Outdoor Activities	042	The Explorer Belt	097
Archery	045	Visits to...	099
Paper Bag Exercise	048	Lets talk!	100
The Coracle	050	Build a fun, folding canoe	102
Venture Fun and Games	052	Camp games	105
Mountain leadership	054	Art is fun	108
Canoe Leadership	056	Mouse Trap cars	110
Town planners	058	Cardboard box ovens	111
Home made stoves	060	Travelling light	112
Power Kites	062	Low level Rope courses	114
Puzzles and games	064	Whizz planes	116
		Specialisation	118

Working with Groups

In Scouting, working with individuals and groups started on Brownsea Island and has been going on ever since. In Scouting, the end is 'the physical, mental and spiritual development of young people'. And in Scouting we use and develop both these situations to achieve that end.

As a Leader in Scouting, and in particular in a Venture Scout Unit you are already involved in a 'group' situation or possibly a series of 'group' situations - whether you realise it or not. How can you use and develop these situations to achieve your ends -and those of Venturing? It sounds a simple question but, like many such questions, it calls for a complicated answer.

The simplest answer is to say that you can only use and develop the group setting, in which you find yourself, if you know something about how people behave in groups, that is, the 'group process'. Once again, this may seem a rather pompous way of stating the obvious. The truth is that, by instinct or by trial and error, you already know a great deal about the group process (even if you do not call it that!). But, however much we know by instinct or have learnt through experience, it is always helpful to check our home spun ideas against those of the expert. Let us look upon your Venture Scout section as a group of individuals with a common purpose -because that is how it would be seen by the expert. This is what the experts have to say.

What Is The Group Process?

A group is any number of people working together. It can consist of two people or twenty people. Experience suggests that five or six is the 'natural' size of a group. A larger group tends to break up, quite naturally, into sub-groups. In any largish group, therefore, you should be able to recognise subgroups, however informal. Most people belong to several groups at the same time - in the home, at school, at work, and in our case the Venture Scout section. Even within your section, a Venture Scout may belong to several sub-groups. He/she may be a member of the climbing group, or one of four who are always together. And he/she may be a member of the Executive Committee, which is a rather more formal sort of sub-group.

When people are together in a group, they influence each other. The interaction of people as members of a group is called the group process.

This process is inevitable. The people within the group cannot avoid influencing one another. Whether that influence is helpful and desirable is another matter (and who is to define desirable anyway?). What we are interested in is, how they influence one another ...

The people in the group play different roles. Someone has the ideas; someone keeps the peace; someone makes the jokes; someone keeps the group together; and someone provides the leadership.

Role of the Leader

The role of the Leader in a group is an interesting one and has always fascinated people. But, in this case, we are only concerned with the fact that, within a group, at any one time, we may expect to find one or more people providing leadership. It is also important to note that people can change the rules within a group. This can occur for a variety of reasons. The aim or the task of the group may change. The membership of the group may change (someone may join; someone may leave). The members of a group of young people, such as a Venture Unit, will be growing up, will be maturing. This will lead to changes in behaviour. Finally, members of the groups will be influenced by the roles they play in other groups (in the family, at school, and so on) and, furthermore, those roles may also be changing.

Changing roles within a group (or, sometimes, not being able to change



them) can produce stress for individual members of the group - and tension within the group as a whole. So, although a group may appear to be static and without tension, it is unlikely to remain so for long. But, despite internal changes and tension, a group can maintain a sort of ongoing equilibrium for quite a long time. Indeed, it must do so to survive as a group.....

Why Group Work?

A Venture Scout Leader can be ignorant of the group process. Or he/she can understand and observe it but, nevertheless, ignore it. Or he/she can understand, observe and use it.

It is better that he/she should understand it, observe it and use it. Unless the Leader uses it, he/she cannot provide effective leadership, nor can he/she provide effective learning experiences for the members of the group. Getting on with people, or personal relationships, is one of the most important aspects of life and of growing up. Venture Scouting offers young people an ideal opportunity to, learn about personal relationships. But this learning can only be done alongside other people, inside a group - in this case, inside your section. When the leader intervenes in the group process and provides leadership or learning experiences for members of the group it is called group work. Our aim is the betterment of those with whom we work. If this is true, we must accept that, from time to time, we must act for its well being.

We cannot just sit back and watch. Otherwise, why did we take up the challenge of youth work in the first place? Briefly, when using this approach, we try to encourage the members of the group to decide everything for themselves. We believe, and experience has shown,

that the successful Leader, whether consciously or not, veers towards this approach. Few leaders have much success when they try to work directly, that is when they veer towards the directive approach and try to decide everything on behalf of the members of the group.

Of course, these two approaches, as defined, represent extremes. Most leaders use a variety of approaches.

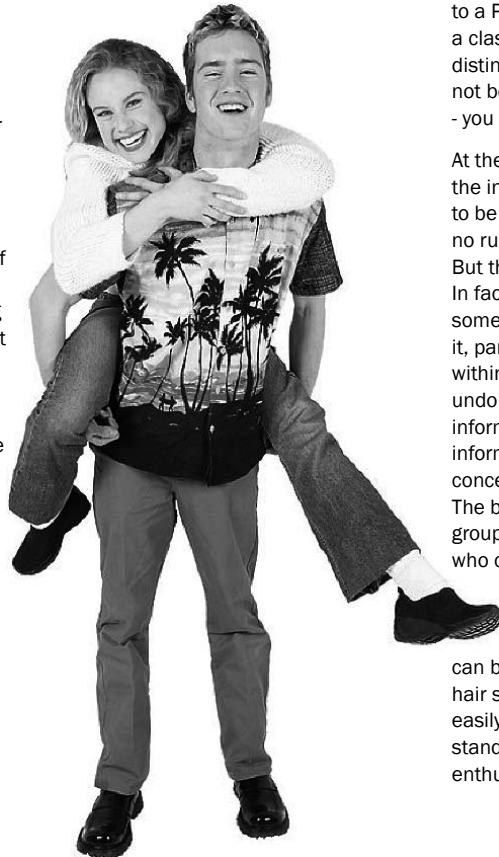

Nevertheless, the Leader who tries to work non-directively has more success in terms of the betterment of those with whom he/she works - than the Leader who tries to work directly.

Formal Group or Informal Group?

The experts recognises several sorts of groups, the formal group and the informal group. The Venture Scout Unit, with its requirements for membership (age, uniform, Award scheme, commitment to a Promise, etc.), would appear to be a classic case of a formal group. The distinction between being a member and not being a member is very clear. You join - you are initiated - investiture, you leave.?

At the other end of the scale, there is the informal group where there appears to be no conditions for membership and no rules concerning joining and leaving. But these, as defined, are two extremes. In fact, every Venture Scout Unit has something of the informal group about it, particularly in regard to the subgroups within it. Any section of ten or so will undoubtedly have sub-groups, however informal. And, on the other hand, the informal group has, in fact, unwritten rules concerning membership and behaviour. The behaviour expected of members of a group is known as a group norm. Those who comply with the group norms belong; those who do not comply are rejected or ostracised.

Group norms are fascinating. Some can be observed easily - clothes, speech, hair styles, mannerisms. Some are less easily observed - beliefs, attitudes, values, standards. These show most clearly in enthusiasm for particular activities - and

often contempt for other activities ... We will find group norms in the ' formal group just as much as in the informal group. The pressure on the members to conform to the group norms is strong and is one of the strongest influences on the development of the individual within the group.

Group Focus

The experts also talk about group focus. They speak of task oriented groups and socially oriented groups.

At one extreme, the group can be solely concerned with a task - with climbing, building a boat, running a folk group, playing football, or whatever. At the other extreme, the group can be solely concerned with the personal relationships within the group, with the interaction of the members of the group. The members meet only to drink coffee, to play computer games, to talk or just to be with one another. Once again, these are two extremes.

No group can be totally task oriented, with no interaction of the members of the group. The football team practice together, travel together, play together, enjoy success (or suffer defeat!) together. They must interact with one another to do all this, particularly if they are to stay together and continue to play football. Equally no group can be totally socially oriented (and engage in no task of any sort). The coffee drinkers come together and must do something even if it is only to organise the coffee! It is impossible to come together and to do absolutely nothing. A task, however modest, will emerge and the group, if it is to remain together, will have to act together. The truth is that the group focus of most groups contains an element of both aspects.

The leader has a responsibility to maintain some sort of balance between these two aspects. The balance should allow all the members of the group to meet their needs, to play a role or variety of roles, and to enjoy success.

People can only benefit from membership of a group if it meets some of their needs. They look for satisfying roles to play. They want to belong and to have status in the group. They want to enjoy personal success and to share in the achievements of the group. If the group does not meet any of their needs, or does not provide them with a satisfying role or some measure of success, they will leave the group.

Your Venture Scout Group -A Cohesive Group?

We have stressed that a group is dynamic. That is to say, it is constantly changing, but at the same time, it remains together, it sticks together. The experts speak of the cohesiveness of a group. 'A cohesive group is one in which the members like

one another, and are therefore attracted towards the group ...

A group will become cohesive under the following conditions: frequent interaction; homogeneity of attitudes, interests and background; rewarding experiences in the group; a Leader who can preserve harmony; absence of aggressive, schizoid or otherwise disturbing personalities; a task which requires cooperative, complementary behaviour for its completion'.

So much for the expert. We now understand the ideas or at least the basic ideas of the experts. Can we see them at work in our own Section?

And can we apply them within our own Group?



The Island

- an exercise in Leadership styles

What style of leadership do I use within my section and with the other adults at Group and County level. Will I play the nice guy and let people get away with murder or will I play the hard military type and "run a tight ship?..." This little story might help to explain:

A group of twenty five passengers are marooned on a desert island along with five officers from their luxury liner that floundered during wild storms. The Officers know the rough location of the island and realise that this spot in the South Pacific is completely off the main shipping lines. The best chance is to build a raft and sail away to safety.

The passengers look to the Ship's Officers for leadership and it is decided that it will be best for all if the group divides up into five teams, each team being led by one of the Ship's Officers. Each team will search the island for a suitable source of raft making material, food and water. If any team gets a raft built they will sail to safety and contact help. Here is an account of how each team got on after they split up.

Team one

The first team was led by the Ship's Entertainment Officer. He had spent many years organising the cabaret, games and dances on board ship. He had great concern for the welfare of the passengers and never wanted to push them too hard. He was the most popular officer of the lot. As soon as the group broke up, he

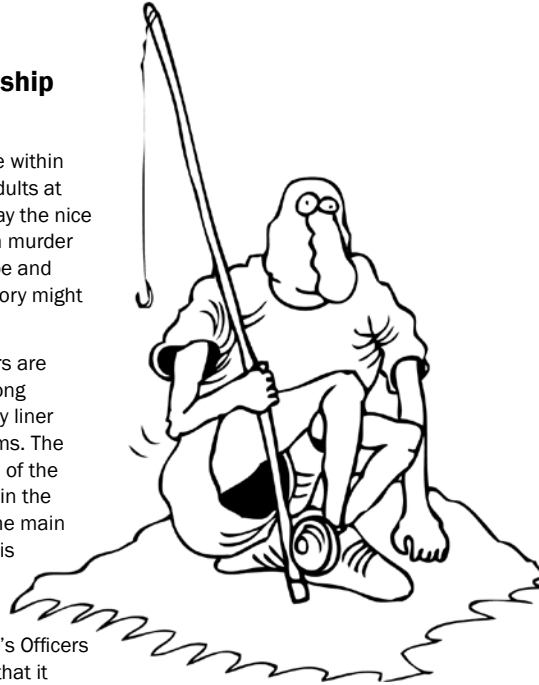

took his team and asked them what they wanted to do. They weren't too keen on travelling East along the island - it seemed too heavily forested. The Western shore looked much easier to travel golden sandy beaches, coconut groves - no real raft making material but nice, easy-going territory. As the beach was surrounded coral reef, making launch impossible.

This team set off along the beach and reached point 1.9 on the map. This, they decided was the furthest they should go. The entertainment's Officer agreed. He didn't want to push them at all, as long as they were happy. He made sure that they had enough food - he let them go swimming as they wished - the lagoon was safe and beautifully warm. Team One

didn't get off the island - but they were all very happy - the Entertainment's Officer made sure of that. He kept them at point 1.9 where they were all very comfortable and he remained as popular as ever.

Team two

The second team was led by the Ship's Engineer. He was a hard old sea dog who believed that the team should get off the island as soon as possible. He had worked with worse teams than this but always came up trumps. Push them hard - that was his motto. Give them no time to think. He chose the Easterly route along the island. At times this looked very overgrown, with some cliff areas along the shore, but there was bound to be plenty of wood there and food and water must abound. He took his team aside, telling them that if anyone didn't pull their weight, they would be left to die. There was no room for slackers here. The survival of the fittest, that's what it was all about!

He pushed his team along the Southern shore of the island for two solid weeks. For much of the time they had to wade through mangrove swamps and once or twice had to scale cliff ledges. They found many sources of timber, food and water, many areas where a launch might have been possible but on arrival at point 9.1 on the map, team two mutinied. One of their members had already died when he fell from a cliff. The others knocked the first mate unconscious and escaped into the forest. The Ship's Engineer awoke at point 9.1 on the island in a daze and wondered what had gone wrong.

Team three

This team was led by the Purser. He was used to taking bookings, counting money, ordering fuel and food. He never really wanted to be a ship's Officer. His father had pushed him into it. All he wanted to do all day was to remain undisturbed. He was happiest when people left him alone. He turned to his team, once the others had gone, and told them he didn't really want the job of leading them. He only took it because he didn't want anyone to give out to him. He didn't really want to get off the island or even make sure that his five passengers were fed and safe. He just wanted to stay where he was and wait, for someone else, to save them. So they panicked, fought among themselves, split up and left him to get more and more depressed.

Team four

This team was led by the Captain. He took his team aside and had a meeting. They made up a map of the island, worked out where the best source of food and materials would be. Then they discussed the skills and capabilities of each member of the team. Balancing the need to get off the island against the capabilities of the team members that they decided to head in a North Easterly direction - avoiding the dangerous swamps. After a week or so they had set up base camp at point 9.9 on the map - a point from which they had easy access to the lush timber and food reserves. There was also an ideal spot for launching their raft - with no fear of crashing on a coral reef. They started to collect timber and build up stocks of food. The Captain worked hard alongside his team. They shared out the work among the team.

One passenger, a carpenter, took on the job of designing the raft, the others started collecting wood. Problems arose from time to time, people felt tired, they saw little progress at times, but the Captain got the team together and discussed the problems - not allowing grudges to build up. Within a month, the team had a raft built and stocked. They launched and spent a week or so on trials. Having sorted out some design faults they sailed away and were discovered two weeks later by an oil tanker and saved.

Team five

The fifth team was led by you. Where exactly would you end up? Which of the first four teams would you follow? You see the first four teams by different kinds of leaders. Each leader had a different emphasis on two things - people and results,

1. The Entertainment's Officer who led Team One was only interested in keeping his people happy. He didn't really care about getting off the island because his people just wanted the easy option - they wanted to laze about on the lagoon rather than work. He didn't even expect them to gather food - he did all that and they loved him for it. He knew that there would probably be a stormy season, but didn't want to bring it up, he just laughed it off. People mightn't like him if he was too serious. His team ended up at point 1.9 on the map so we'll call him a "one-niner".

2. The Ship's Engineer took exactly the opposite approach. He had very little regard for his people - all he cared about was the result which had to be achieved - regardless! He pushed his people hard. He took the side of the island that was obviously going to produce the goods but his people suffered, and as often happens they fought back and left him. He made all the decisions - regardless of whether

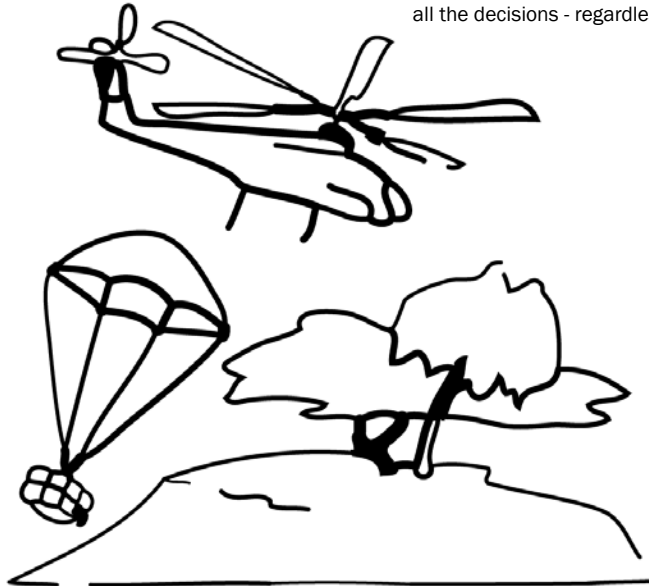

some of his people had good ideas. He won all arguments and made sure the other person knew they had lost.

He ended up on the bottom right hand corner of the island (grid ref. 9.1) so we'll call him "nine-ner".

3. The Purser wasn't really interested in whether his people were happy or not. Nor was he interested in achieving his set goal, i.e. getting off the island. His team could do as they liked as long as they didn't disturb him. As you would expect, his team enjoyed themselves for a while - they did as they wished, but soon panicked, quarreled and left him alone at point 1.1, so we'll call him a "one-ner".

4. The Ship's Captain on the other hand seemed to be able to handle both the people and the task in hand together. While he showed his ability to work his people according to their skills and abilities, he was also able to keep them working towards their goal. He seldom made decisions on his own - by involving the team, he gave them a feeling of importance and -also the quality of decisions was much higher - the carpenter obviously knew what he was talking about when it came to boat building. From time to time his people had arguments amongst themselves and with him. Instead of brushing it under the carpet he made the point of actually discussing these problems, trying to find the root cause.

The Captain made it all the way to point 9.9 on the island, so we'll call him a "nine-niner".

YOU!

So which style do you normally use? How do you go about leading your team of adult leaders or young people in Scouting?

Think of other people in Scouting - what style do they use? Are they "engineers" or "entertainment officers", "pursers" or "captains"? If you are a Venturer Leader, why not use this story for your next training or executive meeting. But the application of this idea to ourselves is what is important. They style of leadership we use has a great effect on the people we work with and of course on the job we do in

Scouting. There are too many ship's engineers in Scouting today and lots of entertainment officers who just want to keep everyone happy. We have some 'pursers' who do just enough to keep their necks out. We don't have enough Ship's Captains around. Those people who would end up at point 9.9 on the island is the kind of leader we need. It's not too hard to become a "nine-niner". It involves developing good teamwork, listening for new ideas, evaluating these, proposing solutions and confronting problems as soon as they arise. Above all it means that at no time do you lose sight of the needs of either the people around you or the task in hand.

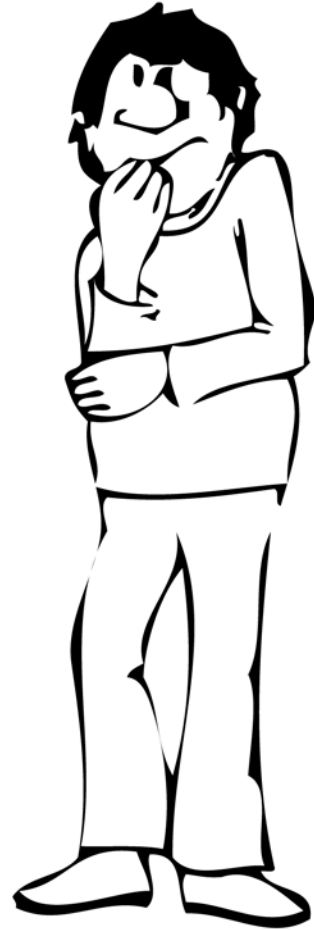

Getting it together

A typical Venture Scout Unit comprises a membership of 8 - 12 young people and two adult Scouters. Most Units are evolved to respond to the needs of young people who have come up through the Scout Section. So, there will be a level of inherent 'scout skill' and expertise within the Unit. It is this expertise that allows the Unit to explore and participate in activities which ordinarily would not be available to young people of this age.

A lot of new Venture Scout Units start in this way - comprised of Scouts - and as they gain confidence in running and managing their section they then invite new members from outside of Scouting.

The size of the Unit is important, a certain critical mass is required to run an effective programme. If the Unit has less than 6 members some of the programme ideas suggested in this handbook will be difficult to realise. At the other end of the scale a group that is too large, in excess of 20 young people, often lacks the tight group/personal involvement element.

The Venture Scout Unit is a cohesive group of young people who plan and organise themselves with adult facilitation and guidance. Whereas in other Sections of the Unit the 'action' is centred around what the adult Scouters plan and provide in the programme, in the Venture Scout Unit the 'action' and 'drive' is provided by its members. Skills that a young person has learnt as a member of the Scout Troop, perhaps as a Patrol Leader are expanded and improved.

Knowing what they want to do and experience is not a problem for any

Venture Scout. Most will be very vocal in this regard, with a little encouragement from the adult Scouters. However, the transition from idea to reality is often the stumbling block. These are great learning experience that adult Scouters can assist and encourage young people to undertake. As each idea is transformed into a great activity or event the Unit gain in confidence and will take on more difficult and complex projects and ideas.

So, looking from the outside in, we see a group of young people, assisted by Adult Scouters, drawing together ideas and plans for things they want to do. Once these plans are agreed, a team of young people will make it happen. They will work out the details and organise the activity. The Unit will take part and enjoy the event. A review of what happened and lessons learned takes place and the Unit then move on to their next idea. So, creates the circle of activity within a Venture Scout Unit.

Organising the Unit

In order to make things happen it will be necessary to create small teams within the Unit who will take on the responsibility to organise an element of the programme. Say for example you have a Unit of 12 members then you might create 4 teams of 3 Venture Scouts for a particular month. These teams do not have to be permanent they can be reformed for the next month so everyone has an opportunity to work together at some stage. In the case of a weekly programme for the Unit - one team is responsible for each meeting.

Teams can also be created to cover the planning of activities.

The job of the Scouters is to work with, encourage and assist the teams in planning and organising the meeting or activity.

So, during a year, a member of the Unit will help to plan and organise at least 12 meetings and perhaps 4 activities. As they work with others and share skills and experience their confidence increases and the quality of the activities undertaken will improve. This method of working involves all members of the section and they feel part of and important to the working of the Unit.

In order for this method to work effectively it needs to be managed by the Scouters. To plan a meeting or activity will take some time so teams need to be created ahead of the meeting and activity. A team should have at least 3 weeks notice of a meeting and at least 6 weeks for an activity. So, a small chart is often useful in this process. Members can see what they have to do and who they are working with. The teams should change with each job of work so that cliques are not created and knowledge and experience is shared across the Unit.

Evaluation and review

The evaluation and review of both the running and programme of the Unit is an important learning tool. This could take place at the end of a meeting perhaps once a month. The Unit should review the activity that has taken place, comment on organisation and provide positive

feedback to teams who have organised and run meetings and activities. This process should be 'short and sweet' prolonged analysis of an event or meeting is often unhelpful. The Scouters should quickly draw from the review process the positive and learning aspects of the experience and take lessons learned to future programme items.

The review period is also a good time to reform new teams as required for the next programmes planned.

In most Units the review process is ongoing, often happening during and at the end of an activity. However, these on the spot reviews are often heated and concentrate mainly on what is going wrong rather than a review of the whole process. The month review is therefore more reflective. It is important for everyone in the Unit to realise that the whole process of forming teams, planning and organising is a learning and developing experience. It is a place where mistakes can be made, and as a result of a mistake lessons and experience is gained. This is particularly important in the first year of operation of a new Venture Scout Unit. As a Unit develops it creates within its membership different levels of experience and expertise. The skill of the Scouter is then in the creation of mixed ability teams where on - the job experience can be gained by all in the team.

So, in practical terms most Units have a meeting on a monthly basis - perhaps at the end of a fun planned meeting by one of your teams. This 'formal' part of the meeting will discuss and create new ideas, review the programme over the past few weeks and create teams for new programme items in the future. They will also deal with the formal business of the Unit as required. This section of a meeting

would normally last for about 45 minutes. There will of course be many opportunities at meetings and activities to chat and discuss many aspects of the Units programmes and plans but this 'formal' part of your meeting should be the place where decisions are formally made and agreed by all.

'Rules and regs'

A Venture Scout Unit is like any other group. Interpersonal skills and group dynamics will come into play resulting in at times conflict and 'madness' for that reason agreed rules and regulations need to be drawn up by everyone involved to enable the Unit to operate in an atmosphere of relative calm and harmony.

There will also be formal rules and operational rules which need to be obeyed. These rules could be formal Association or Group rules related to the management of your Group or the Association and which we agreed to abide as members of Scouting.

There are society rules and norms which also need to be considered.

So, early on in the creation of a Venture Unit the Unit have to sit down and create the constitution and rules of the Unit. These rules can be reviewed and amended each year at the Annual general meeting of the Group if they are deemed to be unsuitable or in need of change. New rules can also be introduced at this meeting.

This process is best managed by the Scouters as it allows everyone to have a free discussion.

In drawing up a set of 'rules and regs' aim to create a short-list rather than a 30 page handbook.

Seven or eight key rules that are clear and easy to understand or better than wordy paragraphs with a number of sub - divisions.

You will need to consider the following:-

The use of facilities - when they can be used, cleaning up duties, obligations with regard to the use of the facility.

Management of the Unit - Scouters and young people. If you have a Chairperson what powers do they have.

Dealing with conflict

Dealing with relationships - of particular importance if you have a mixed Unit.

Management of monies - subs, activity costs, camp bank.

Attendance at meetings and activities.

Wearing of uniform

How 'teams' work and what are they expected to do.

The Scout Promise and Law

Setting limits on behaviour

As you can see it will require some discussion to achieve a working document. When the document is agreed each member is then expected to sign this document, indicating that they will abide by these rules. This is important because if it is necessary to discipline a member of the Unit for stepping out of line it is done so with reference to the Scout Law and Promise and the rules of the Unit.

So, the power to address an issue and in effect 'give out' to someone in the Unit, by say the Unit Chairperson, derives from implementing the rules rather than a personal attack on a member.

Sample rules and regs sheet

204th Dublin Venture Scout Unit.

Rules and conditions of membership

This charter has been compiled through a formal process undertaken by the 204th Dublin Venture Scout Unit. During this process each rule and condition was fully discussed and explored and finally voted in by members of the Unit.

This Charter is a living document and can be amended and changed as the Venture Scout Unit wishes, and as situations change. These Rules and Conditions are reviewed annually at our Annual General Meeting though a process of formal resolution, discussion and vote process. Each member has a vote at this meeting. It is also possible to change this Charter at other time outside of the Annual General Meeting, by calling a special Emergency General Meeting (EGM). In order for this to happen 90% of the membership must agree to this meeting taking place.

A member is any young person who has formally being invested into the Unit. (invested as a Venture Scout)

1. Venture Scouts are expected to have full and proper uniform and will wear it when indicated by the Scouter in Charge.
2. Venture Scouts are expected to attend all meeting and activities of the Unit, unless they indicate to the Scouter in Charge that they cannot attend.

3. The atmosphere and behaviour in the Unit is one of friendliness and welcoming, particularly in the case of new members, or when helping with other sections.

4. The law of the Unit is the Scout Law and Promise.

5. Bullying of all kinds is not allowed. Any member who is caught or is reported to be involved in such behaviour will receive one formal warning only. A second incident will result in the termination of their membership.

6. The weekly subs of the Unit is set each year at the AGM. Members are expected to pay this on a quarterly basis,

7. It is expected that all Venture Scouts keep their Scout Skills up to date. New members should be assisted to learn the basic Scout Skills.

8. No matter what venue we use we will leave it cleaner than it was when we arrived, even if the untidiness was not caused by our activity. This is particularly the case with regards to our meeting room. Tidying up is the responsibility of every member.

9. The associations rules with regards to mixed or co-educational activities will be observed at all times.

11. Venture Scouts should observe the simple rules – no drink, no drugs, no sex.

12. The Unit will participate in all Group activities when requested even if

we don't agree with the activity (fundraising, field days and functions for example)

13. One member of the Venture Unit will be elected each year to participate as a 'Young Person Rep' on the Group Council.

14. All disputes within the Unit will be dealt with fairly and in accordance with the 'Code of Good Practice' and rules of the association. It is hoped that disputes of all kinds can be dealt with quickly and will not need to be brought to a formal discipline setting.

15. The officers of the Unit – Chairperson, Secretary, Treasurer shall be elected by all the members of the Unit. Their term of office is determined by the Unit. The maximum term of office is one year. (This Unit like to give everyone an opportunity to hold one of these positions in a programme period. So a term of office may only last for 3 months, for example, but if a circumstance arises that a person holds a position beyond this time period, the maximum period of office is one year)

I agree to abide by the rules and conditions as outlined in this Charter. I fully understand why this Charter is necessary and the rules and conditions have been explained to me.

Signed _____

Date _____

Evaluation - Happy Charts

People talk quite naturally of their ups and downs, highs and lows, being as high as a kite or down in the dumps.

A Happy Chart is simply a graphic way of recording these fluctuations.

A happy chart can ...

- ... be used to increase awareness of self and others, before or after activities.
- ... help in the review of planned or unplanned events involving groups or individuals.
- ... make it easier to talk about feelings, and it can stimulate interest in how other people have been feeling during an activity.
- ... help people to feel more noticed and understood by others: 'I didn't think you knew what I was feeling!' 'I didn't know you felt like that!'

The event to be 'charted' should be divided up by the group into about ten parts, with some assistance from the Scouter.

- Explain that the purpose is to chart personal ups and downs, including people's highest and lowest points.
- To bring out individual differences, include moments when people seemed to be going through different experiences from each other.
- It is a good idea to save the first one or two scores for the period leading up to the start of the event, perhaps even going back a day or two. And

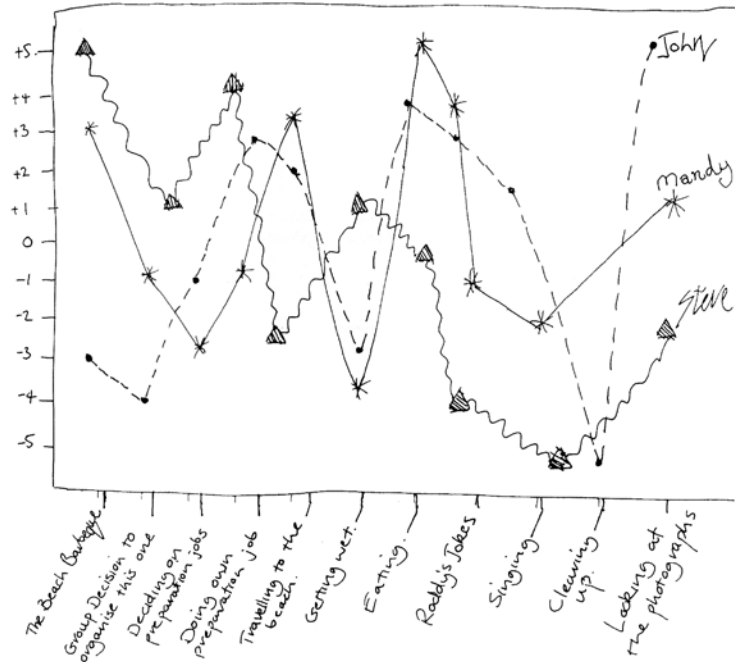

if the 'Happy Chart' review is not taking place straight after the event, it is worth saving one or two scores for feelings since the event.

Each person records a number from minus five to plus five for each of the ten or so occasions that have been agreed.

Each person takes a different coloured pen and draws their line on a large chart (approx. 2 metres long), signing their line at each end.

- If there are not enough colours to go round, symbols can be used.
- The chart should be big enough for each person's line to be clearly seen.

Scout Promise and Law

A Scout is “friendly, courteous, kind, cheerful, brave” explains Baden-Powell:

“When in difficulty; to know which of two things to do, [the scout] must ask himself, ‘Which is my duty?’ that is, ‘Which is best for other people?’—and do that one.” A Scout observes traditional rules of chivalry: he is “polite to all, especially to women, children, old people, and the weak and helpless.” He must obey an ironclad law of personal integrity: “If a Scout were to break his honour by telling a lie . . . he would cease to be a scout—he loses his life,” warns Baden-Powell.

The Scout Law and Promise are the basic elements that underline Scouting. The Scout Promise is a personal commitment to live by the Scout Law, do one’s duty to one’s beliefs and acceptance of a spiritual reality, and to the service of others.

The Scout Promise

On my Honour, I promise that I will do my best to further my understanding and acceptance of a Spiritual Reality, to serve my community, to help other people and to live the Scout Law.

The Scout Law

A Scout is to be trusted

A Scout is loyal

A Scout is helpful and considerate of others

A Scout has courage in all difficulties

A Scout makes good use of time and is careful of possessions and property

A Scout has respect for self and others

A Scout respects nature and the environment

The Scout Law is a moral code that members of Scouting are expected to do their best to live by. The Scout Law is based on the common or core universal virtues and character traits that should be displayed by good decent people. These virtues are based around the idea that society is better for everyone if you live your life according to the principle of ‘Do on to others as you would have done on to you’.

The Scout Law is an invitation to live according to fundamental values: uprightness and loyalty (is to be trusted, is

loyal); respect for, and solidarity towards, others (to be a friend to all, to be helpful and considerate of others, to respect others); protection of life and nature (to respect nature and the environment); a positive attitude to life’s ups and downs (to have courage in all difficulties); a sense of one’s own dignity (respect for self); to be diligent (make good use of time and care for possessions and property).

The Scout Law does not forbid anything. It is an invitation or code to develop oneself, to become more humane. The Scout Law promotes the ideal of ‘scout like’ behaviour and attitude. It is practiced and learned in real life situations within the team structure of each section – Lodge, Six, Patrol, Venture Unit and as adults within the leadership team structure.



The Promise is the starting point of our understanding and a real belief that the doing of one's best to live by the Scout Law is what a person chooses to do when they become a Scout. It is because he/she wants to live according to the Scout Law that he/she will set personal goals and achievements to reach through Scouting activities and everyday life.

As a young person grows within Scouting, they acquire and develop certain character strengths: sound judgment, a sense of responsibility, personal confidence and courage. These habits are built upon with the addition of the Scout Law in their lives as an underlying code of commitment.

Rules

The Scout Law is not a rulebook but more a personal challenge. As an underlying principle of Scouting it will be reflected in many aspects of Scouting. The way we



behave with others, the rules of conduct we draw up and also the measure by which misdemeanours are judged.

The Scout Law is the foundation on which the whole of scout training rests (B.P. Aids to Scoutmastership)

The boy is not governed by D'ONTS, but led on by DO. The Scout Law is devised as a guide to his actions rather than as repressive of his faults (B.P. Aids to Scoutmastership)

The Scout Law and Promise in practice

The Scout Law and Promise are an encapsulation of the spiritual elements of our Programme.

Friendship and fellowship - how we work with and interact with others in a Scout like fashion. The Scout Law expresses this as – A Scout is helpful and considerate of others. A Scout is to be trusted, A Scout is loyal, A Scout has respect for self and others. In the Scout Promise – to help other people. So, 4 parts of the seven-part Scout Law and one part of a four-part commitment within the Scout Promise relate to how we work and interact with others.

The original Scout Law as contained in Scouting for Boys listed 10 points of the Scout Law, which included

A Scout is to be trusted

A Scout is loyal

A Scouts duty is to be useful and to help others

A Scout is a friend to all, and a brother to every other Scout, no matter to what country, class or creed the other may belong.

A Scout is courteous

A Scout is a friend to animals

A Scout obeys orders of his parents, Patrol Leaders or Scout Master without question.

A Scout smiles and whistles under all difficulties

A Scout is thrifty

A Scout is clean in thought, word and deed.

Again we can see from the list above the importance of friendship, fellowship and the working with and care of others. With friendship comes love and kindness and through friendship it is easier to practice the principle – do on to others as you would have done on to you. Friendship is the key to this whole process. The Patrol system/Team structure within Scouting and the closeness within the Venture Unit allows this feature of scouting to blossom. Young people and adults join Scouting as a result of friendship and remain in Scouting through friendship. Friendship is the glue that bonds people of many backgrounds and interests together.

As leaders of young people's friendship is perhaps the single biggest tool available to us to assist young people in their development. Within Scouting, friendship is used in a positive way, the Scout Law and Promise directing young people towards positive rather than negative actions. Young people and adults easily understand the concept of friendship. It is a vital part of our lives and essential for our happiness. The best expression of friendship is love and marriage, a life long commitment to another person.

The face of Scouting is friendship. As Scouters explaining the Law to young people, friendship is simple to explain and practice. Young people should be encouraged to make new friends

and maintain their friendships with others. Conflict should be resolved through friendship. Guiding rules for the management of Scouting in our sections should reflect this feature as well as other elements of the Scout Law.

Doing a daily good deed or act of kindness

The ideal of 'Doing good deeds and acts of kindness for others' is a keystone of Scouting in building bridges to friendship and providing unselfish service to others.

'There isn't anyone who doesn't appreciate kindness and compassion'.
Dalai Lama

The good deed, act of kindness, and service idea is perhaps the biggest spiritually fulfilling act that we can do. The Scout Law and Promise is written around this ideal. Religious beliefs and practices encourage these acts of kindness as a pathway to God and personal fulfillment. The beauty of this idea is that it is easy for everyone to understand no matter what age he or she are. So, from an early age a child can be encourage to do a good deed every day, this deeds can be small, but completed unselfishly. Later, the good deed will become a feature of their daily life undertaken at any opportunity. In a collective group such as a Venture Unit the good deed can have greater impact as a result of the size of the project/service to others.

Leadership is about example and encouragement and we need to ensure that the good deed idea is maintained and becomes part of what we are and what Scouting is - 'to give and not to count the

cost', 'to serve my community and help other people'. The promotion and practice of this ideal will lead young people to better understand Scouting and place the Scout Law and Promise in a practical context in their daily lives.

Scouts Own

The 'Scouts Own' is an ideal opportunity for young people to explore elements of the Scout Law and Promise and how they impact on their lives. A 'Scouts Own' for example can be theme based perhaps focusing on one of the Scout Laws. 'A Scout has courage even under difficulties' what does this mean to those taking part ? It can relate to physical things - being cheerful in bad weather for example but it can also relate to having the courage to stand up for what is right, to fight for the oppressed, to stand up for a religious belief. The 'Scout's Own' can put the Scout Law and Promise into many situations that can broaden the thought

processes of those taking part so that they can reflect on how the Scout Law effects their lives daily.

Its everywhere, its all around us

As Baden Powell said *'The Scout Law is the foundation on which the whole of scout training rests'* (Aids to Scout mastership) it can be seen from the above that this statement is indeed true. The Scout Programme, our structure, our underlining principles and the Scout Law and Promise are all intertwined in what manifests itself as Scouting. You cannot operate any element by itself and call it Scouting. Scouting is the collection of the whole. The Scout Law and Promise is everywhere, it is all around us.



Yearly Programme Plan

First years programme suggestions at a glance.

January	Keep Fit night	Mountaineering night Crystal Maze Challenge	Recruitment night	Photography night
February	Guest speaker - Chef/ Cook	International Cooking evening	Making Bivvy's T-Shirt printing	Your Den
March	Map reading skills Hobby input Memory Skills	Spy Night - wide game for the Troop	Rope work Hobby input	The Challenge Game Town Planners
April	Street Theatre	Night Drop Incident	First Aid incidents Team games Survival Skills	First Aid Great Egg Challenge
May	Orienteering	Bike maintenance Survival Skills Local History	Bar - B - Que	Video/Film Production Swimming
June	Video/film making	Pioneering Archery	Treasure Hunt	Fishing Trip
July	Hobby Input Whittling	Art Night	Bar - B - Que	Visit to ...
August	Camp Games	Annual expedition	Annual expedition	Self defence Cook a meal for 5 euro
September	Annual General Meeting	Visit to ...	Kite making/flying Car Mechanics	First Aid Lateral thinking
October	Third World night	Inter - Unit night	Wide game for the Troop	Radio production/Radio ad/Radio play
November	Scout Craft evening	Mock trial	Jamboree on the air Advertising - its effects on us	Candle making Computer games Pottery
December	Money Management Cooking on a stove	Weather forecasting Games of chance	Christmas party	New Years Eve party

Year Activity Plan

Below is outlined a yearly activity plan which compliments the weekly programmes that follows. These are only suggested activities, the members of your Venture Scout Unit will suggest many more possibilities. What needs to be noted is the variety of activities on offer. Hopefully everyone will enjoy all of your activities but over the year try to incorporate the 'likes' and favourites of all the members of the Unit.

January		Cinema/Theatre/ Skating	Hosteling weekend	
February	Work/service weekend at local campsite		Photography day	Night Hike
March		Leadership Skills course	Orienteering Event	
April	Hillwalking weekend		Abseiling Day	Rescue techniques
May	Canoeing	Running a base at Cub event	Rock Climbing	Cycle Hike
June	Backpacking weekend	Pitch and Putt or Golf	Orienteering event	Pioneering activity with Patrol Leaders
July	Rock Climbing	Raft Building Inter - unit race/competition	Cyclocross/Mountain biking	
August	Canoeing/sailing	Annual expedition	Annual expedition	
September	Horse riding	Night hike/ bivvy out		
October		Day Hike		Power Kiting and karting
November		Environmental project	Skills training for Troop	Hosteling weekend
December	Good turn Project	Treasure Hunt	Christmas party	

January

Keep fit night

How fit are the members of your section? In order to live a long and sickness free life it is important that we live our lives in a healthy way. Exercise, diet, and a healthy attitude to your lifestyle will add to your enjoyment of life. The meeting should centre around the physical fitness of your members. You should also source as many pieces of information that is available related to diet, smoking, drug abuse etc. This information can be had from your local health board. You may also want to consider having a guest speaker along to the meeting. It maybe, a doctor or dietian or perhaps a sports coach. It is important that the meeting should have a variety in its content and should not evolve into a big discussion about drug abuse or a row about underage drinking or smoking.

The meeting should have as its aim a thought provoking effect that will encourage the members of the Unit to re - think or plan a programme of healthy living.

Mountaineering / Crystal Maze challenge

The meeting tonight will have two elements a mountaineering feature and a challenge game. Each item involves some work before the meeting. This entails :-

Contacting a mountaineer at least a few weeks before the meeting in question and ask them would they be willing to introduce the sport of mountaineering to the Unit. This may entail a slide show, demonstration of equipment, a short



talk. If you have a problem contacting a local mountaineer then contact the Irish Mountaineering Council or your local V.E.C. and Adventure Centre. If all else fails then contact the Mountain Pursuit Challenge Team in National Office.

Setting up the Crystal Maze Challenge (as presented on page 64). How you set up the game depends on the number of players. You should allow at least an hour to complete the games.

Recruitment Night

The Venture Unit on show - an evening to show off the Unit to the public, parents, Scouts and Patrol Leaders. New members are the lifeblood of every Unit and must be constantly sourced from the publics available to you. The purpose of the evening is to attract attention to the Unit, as a result of this attention a number of people may show an interest in Venturing. It is important that as a result of interest shown by a person that this is followed up

as soon as possible. One way of doing this is to have a follow up event like a hike or a bring - a - pal activity.

This evening will involve a considerable amount of planning in order to ensure success. Displays will have to be constructed, invitations sent out, slide shows put together, food organised, press releases issued etc., therefore the whole evening will be a Unit activity with everybody involved in the planning and execution of the evening. Even if you do not recruit anybody from this evening, you will have done a valuable public relations exercise for the Unit.

Photography

This programme item offers a number of opportunities to the Unit. The first problem is to obtain the support of a local photographer who would be willing to talk to the Unit about photography. It is important that you solicit the help of someone who knows what they are talking about and not 'Mary's brother who does a bit of photography'. Such a person maybe a professional photographer or a member of a Camera Club. What is proposed is to have a general introductory talk about photography covering as many aspects as possible. This talk could be followed by a practical session perhaps on portraiture or still life photography, this would be done in conjunction with the invited guest, the Unit may wish to bring along their cameras for this part of the evening.

Lastly, you may wish to round up the evening by having a 'Face's of the Unit' or a 'Who's Baby' Competition. This entails some members of the committee sneaking around the members houses and asking their parents for baby pictures and snapshots of the members. These photographs are then carefully presented

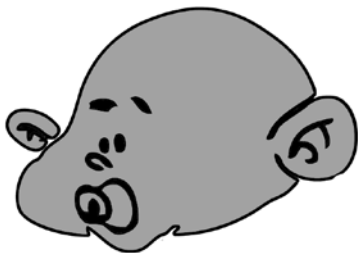

to the Unit mounted on card or in plastic bags to prevent damage. The Unit has to guess who is who. You can be sure the person in question will not be too willing to speak up and will more than likely be extremely embarrassed. However, everyone will have their turn and the competition can be great fun.

February

Guest Speaker - Chef / Cook

The meeting has two items on the programme. The first is a guest speaker who will talk and demonstrate to the Unit the finer points of food preparation and cooking. The purpose of this input is to prepare the Unit for the meeting next week - International Cooking Evening. You may also consider a mother or father of one of the members of the Unit who is into cooking. At the end of the presentation you should break up the Unit into teams (team size depending on Unit numbers) and have a raffle as to the choice of country from which they must prepare a dish for the next meeting. The teams have a week to research and prepare their meal.

International Cooking Evening

Following from last weeks presentation and allotting of countries each team must now prepare the meal they have selected. The rules of the competition should be along the following lines: -

You must select a simple dish from the country allotted which best represents the cuisine of that country.

No prepared dishes are allowed i.e. a jar of spaghetti sauce added to a bowl of



spaghetti or food from a packet. All food must be prepared from scratch at the meeting.

Each team should only be allowed to spend approx. 10 euro or less on ingredients.

Each team is responsible for cooking utensils and equipment. Don't forget the plates, knives and forks or chopsticks etc.

Other practical arrangements in accordance with the meeting place used etc.

Each meal could be judged by all members of the Unit or you may like to invite a number of outside judges and have a prize given to the winners. Marks should be given for such things as ingredients used, choice of meal, preparation, flavour, presentation etc.

Making Bivvies / T - shirt printing

The meeting has two items to the programme;:-

The making of bivvy sheets and the practice of erecting different designs. This will involve the purchase of a roll of heavy gauge plastic sheeting , eyelets and sisal or light rope. It is better to construct a number of bivvys each holding two to three people rather than one or two big ones. These bivvys will be used on the up and coming night hike.

T - shirt printing - you will need a computer and ink-jet printer and iron - on transfer paper. Design a logo for the Unit then print out transfer sheets and iron - on logo onto t-shirts or any other gear which has to be branded. You could also try some tie - dyeing.

Each member of the Unit should also bring a number of items to the meeting on which to print the designs. If this is the first time you have ever tried tie - dyeing or iron - on transfers then you may well be advised to buy some cheap material to practice on before submitting you new sweat shirt to the process.

Your Den

When was the last time you painted the walls in your den / meeting place.? Do you have your own room in the den/ meeting place? How comfortable is it? Is it modern in design? What is the seating like? When was the last time something new went up on the notice board? Do you have a notice board? is your meeting place functional ? Do you need a new meeting place? All the questions you should be asking yourself before this meeting because the purpose of tonight meeting is to set the place right, so get your hammers and paint brushes into action and set to work.

As you can imagine it will require planning well in advance, design proposals drawn up and if necessary permissions obtained from Group Leaders or Group Councils, materials bought and a plan of work put into action. You may require some specialist help from parents so request this assistance well in advance. ' Many hands make light work' so make sure everyone has a task to do. There is no point in everyone watching someone else cutting the timber for a bench. Plan the tasks to be done and create small and large teams to complete each stage

March

Map Reading / Hobbies/ Observations tests

A collection of programme items for tonight meeting:-

Map reading skills are a very necessary skill when we embark on hikes or adventurers in wild and open countryside

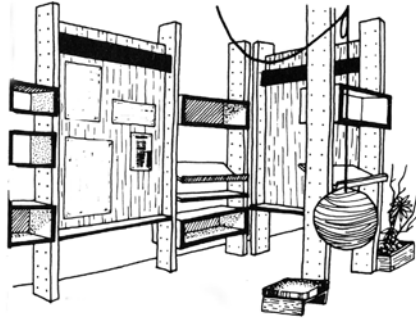

and practice makes perfect. Set up a series of exercises/ games designed to test or reinforce whatever map reading skills are present in the Unit. If on the other hand your Unit would consider themselves pretty dismal in map reading skills then organise a little training session. This item is by way of setting the scene for the orienteering event planned for this month.

Everyone has their own personal hobby. No doubt someone in your Unit has an unusual hobby. Even if their is nobody in your Unit with a strange hobby you should set up a number of presentations whereby a member of the Unit can present their hobby to the Unit. All these presentation do not have to be on the same night. Certainly have one presentation to -night and appoint a series of nights over the year in your programmes for each member to make a presentation. This exercise is a useful way of developing presentations skills and confidence in the individual.

Memory skills

It is proposed that the next meeting will be a joint meeting with the Scout Troop where the Unit will run a Wide game based around a spy theme. Part of this game might be based on Kim's Games. Therefore it would be useful to examine the purposed games and try them out. Such as observation games and skills, tracking, and memory games -you can improve your memory skills and have a bit of crack. Don't forget the finer details of the game for next week.

Wide game with Troop

The meeting tonight is a joint meeting with the Scout Troop and will take the form of a wide game that the Venture Unit has organised for the Troop (see Wide Games page 73 or make up your own). Needless to say the details will have been worked out prior to this evening activity with the Scout Leader and the Court of Honour, The Venture Unit and others will be responsible for running and manning the bases which will form the game. Some of the Unit may also stay behind in the den/meeting place and prepare supper for those returning later. If it is purposed to run the game in the locality of the den you may want to consider putting a Venture with each Patrol for security and piece of mind.

Ropework

Abseiling, fireman chair knots, triple bowlines, belays, rope ladders. Knots have practical uses and in the case of to - nights meeting we want to examine and practice rescue knots.

We never know when we will have to be in a position to put these knots into effect

and it is worth while learning how to do the knots and practice using them. The nature of the Venture programme is that you are likely to be in wild countryside a lot therefore the chances of an accident are heightened. As they say 'practice makes perfect'. In order to set up this session you are going to need some ropes and climbing gear and an area in your den hall to practice from. If you do not have an elevated area available you might consider getting the loan of some scaffolding or using an area out of doors. It is a good idea to set up this session with your mountaineering guest speaker earlier in the year. He / she will have the gear and will be able to assist.

Even though you are in a practice situation you should take care to ensure helmets are worn and that the 'victims' are not in any danger. If in doubt use dummies as 'victims'.

Hobby input

You may also wish to have a hobby input as part of this meeting if a presentation is prepared.

The Challenge Game / Town Planners

Two exercises for to-nights meeting each has a resource material to explain the details.

The Challenge Game will require a little organisation as teams have to be formed and materials obtained before the meeting. It is not necessary to do all the challenges on the resource sheet, Run the game for about an hour doing a variety of challenges.

The Town Planners exercise is a practical role play game which has a number of



stages. Again this exercise should be tightly controlled otherwise it could go on for days. Set strict time limits on each stage.

April

Video Production / Swim

Arrange with the Unit before hand for them to bring along towels and swimming gear for this meeting.



Arrange a swimming session in a local swimming pool prior to the meeting. Or if you live near a popular swimming area like a lake or beach then have your swim there. Don't forget safety measures and the buddy system when swimming in open areas. Nowadays it is quite easy to get your hands on a video camera, so it brings the possibility of video production within your grasp. In preparation for next weeks meeting which will be devoted to the production of a film, in will be necessary to familiarise ourselves with the equipment and prepare a script for the film next week. You may wish to have some input from an expert to help in this familiarisation. Your local V.E.C. maybe able to help locate one, failing that consult a book in the library. Make sure everybody has a job to do next week.

Street Theatre

An evening based around the concept of street theatre. What happens is that each member of the Unit or in teams put together an act in the style of street theatre. Each person/ team has an hour to prepare and practice then each should perform in turn. The acts should be novel and amusing in nature and should employ one of the performance methods outlined in the resource article which include such skills as mime, street bands, juggling, puppetry, magic, circus acts.



Night Drop incident

Phone/text the members of the Unit the day before the meeting and tell them to wear warm clothes and boots to the meeting. Arrange as much transport as necessary so that it is possible to drop off the Unit in one lift. Arrange a base and six drop off points in an area approx. 3 - 4 miles from the base.

When the Unit arrives at the den divide up the Unit into teams. The teams are now blindfolded and driven to the drop off points. As each team is dropped off they should be given a map of the area and an emergency envelope which should contain instructions to get the team to base camp. The teams have to make it back to base

as quickly as possible. At base camp you should have soup and sandwiches available for returning teams. This is the basic activity; you can add various refinements if you wish such as secret police to patrol the roads or giving the teams simple tasks to perform or items to collect on their way back to base.

First Aid/ Team game/ Survival skills

This evening programme offers:-

First aid incidents. A number of incidents should be set up and the Unit acting collectively or in teams should deal with each incident. This exercise should be used to practice first aid skills and to show up shortfalls. You could solicit the help of the Patrol Leaders to act as victims for



this exercise. An analysis of the exercise should take place after the exercise.

Team Game. Whizz Planes is a game designed to develop team building skills. It has two parts the construction phase and the testing stage. A time limit is required in order to control this game (see page 116).

Survival Skills

An input session/talk should be organised to go through the main point of survival and some of the skills that can be used in order to survive. There should be practical exercises as well as an input session

First Aid / Great Egg Race

Following from last weeks programme item on first aid you should organise a practical session based on learning or revising first aid skills. You may wish to bring along a first aider from the Red Cross or St. Johns Ambulance to help. You should concentrate on the main treatments rather than rare conditions, in effect simple first aid treatments.

The Great Egg challenge is a bit of fun. The object of the challenge is to transport

an egg intact from one point to another in a milk carton. The game will involve the teams in the construct of the vehicle employing as many engineering principles as necessary. (See page 67)

May

Orienteering event

The programme to night should be set in a local forest or park involving the Unit in an orienteering activity. This activity maybe set up in conjunction with an orienteering club who will be able to supply proper orienteering maps and punches. You may wish to ask along Patrol Leaders and older Scouts to beef up the competition. If it is impossible to contact an orienteering club locally then you should set up a course along orienteering lines with proper controls and using a blown up map of the area or a larger scale map. Try and set up and run the activity as close to the rules of a proper competition.

Bike maintenance / Survival Skills/ Local history

Three items for consideration :-
In view of the fact that a cycle hike is planned for the end of the month some time spent on bike maintenance and care will pave the way to a successful hike. Practice on such items as puncture repair, setting brakes, setting saddle and handlebar heights, tightening nuts and bolts, safety equipment. You may wish to invite a bike repairman to the meeting from the local bike shop to advise or perhaps someone from a local cycling club.

The second item is a follow on from a session given a few weeks ago. The aim

of this session is to further expand on the skills needed for survival. Details of these skills can be had in the Scouting Trail. An excellent book on the subject is the S.A.S. Survival handbook by John Wiseman.

The third item is based around the subject of local history. How much do you know about the area you live in? What are its



landmarks? What research can the Unit do? Can the Unit preserve any noteworthy landmarks /places of interest in the area? What about our own family histories? This subject can offer the Unit a wide range of activities as spin offs from tonight's input. You should seek the help of a local historian or perhaps members of the Local Historical Society who might give an input into tonight's programme item.

Bar - B - Que

Organise a Bar-b-que for tonight's meeting. Send out invitations to guests or invite another Venture Unit or Ranger Company . Don't forget to set up the bar - b - que well in advanced as the charcoal needs to have settled down before cooking begins. It is also a good idea to boil sausages before they are cooked on the fire. Likewise the burgers can be half cooked and kept warm so that they can be finally cooked up quickly.

Video Production / Swim

Arrange with the Group before hand for them to bring along towels and swimming gear for this meeting.

Arrange a swimming session in a local swimming pool prior to the meeting. Or if you live near a popular swimming area like a lake or beach then have your swim there. Don't forget safety measures and thu buddy system when swimming in open areas.

Now a days it is quite easy to get your hands on a video camera, so it brings the possibility of video production within your grasp. In preparation for next weeks meeting which will be devoted to the production of a film, in will be necessary to familiarise ourselves with the equipment and prepare a script for the film next week. You may wish to have some input from an expert to help in this familiarisation. Your local V.E.C. maybe able to help locate one, failing that consult a book in the library. Make sure everybody has a job to do next week - we can't all be the camera operator

June

Video production

Lights! Camera ! Action! -video production in action. Following on from last weeks meeting tonight you will make the film. This will involve everyone as some members of the Unit will have to be cast members, other in make up, stunts, direction, sound etc. Don't forget to try some special effects and send out tickets for the World Premier.

Pioneering / Archery

Two items for tonight's programme :-

Pioneering

Pioneering is an excellent team building exercise and provided equipment is readily available an exercise that can be organised quickly. What is required is a selection of projects which should be possible to build within an hour. After that what is required is to create teams and lead them at it. Don't forget the tidying up and putting away of equipment.!(see resource article)

Archery

Archery is an excellent sport to participate in on a June evening. Equipment is the problem so contacting a local adventure centre or archery club will help if access is a problem or you could also make your own - just as we did when we were kids. The fun of archery is in hitting the target so homemade equipment is just as good. Bows and arrows are dangerous weapons and therefore great care should be taken at all times. Strict rules should be laid down at the beginning of the activity and enforced, (see resource article)

Treasure Hunt

Get a small team of whizz kids together to put together a treasure hunt around the area maybe inviting friends or older Scouts to take part also. The activity could finish with perhaps a campfire or mini bar - b - que or at the local chipper / cafe. There should be a treasure containing whatever - goodies, vouchers for the chipper, jewels etc.



Fishing Trip

Get your fishing rod or bamboo poles , sisal, safety pin and worm and head for the nearest river, lake, pier. If you do not have equipment contact local fishing / angling club who may assist you. Either way even if you have equipment the help of a local angler will help to develop your angling skills. Who knows you may even catch a fish or two. Why not finish off the evening by planking the fish over an open fire. Yum! Yum!

July

Hobby input and whittling

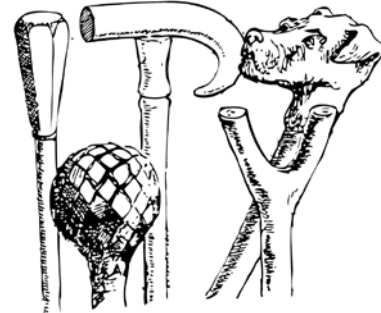

Hobby input

Everyone have their own personal hobby. No doubt someone in your Unit has an unusual hobby. Even if their is nobody in your Unit with a strange hobby you should set up a number of presentations whereby a member of the Unit can present their hobby to the Unit. All these presentation do not have to be on the same night. Certainly have one presentation tonight and appoint a series of nights over the year in your programmes for each member to make a presentation. This exercise is a useful way of developing presentations skills and confidence in the individual.

Whittling

Have you ever sat down on camp, picked up a piece of stick and started carving or whittling something out of that piece of wood. Whittling is the craft of carving with a penknife. All sorts of things can be carved from walking sticks to tent pegs. When setting up this activity you should also lay on the means to sharpen the knives. A small bush saw is also useful for cutting away unwanted wood quickly. (See Scouting Trail)

Art is fun night

Art is a way that people can express themselves artistically. In order to do this you do not have to be a Michaelangelo. Everybody has the capability to paint a

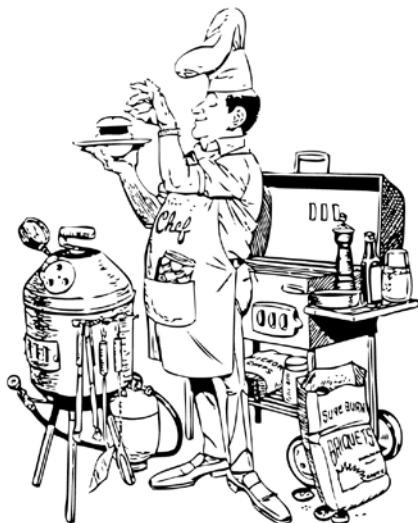

picture or sculpt an object. There are many mediums by which this can be done and to - night we will explore some of them. If the evening is bright you may wish to grab your canvas and paint brushes and head to the country and paint that masterpiece.

Bar - B - Que

Organise a Bar - B - Que for tonight's meeting. In this warm weather the place to be is outside, so why not have a bit of crack at a 'barby'. Don't forget to set up the bar - b - que well in advanced as the charcoal needs to have settled down before cooking begins. It is also a good idea to boil sausages before they are

cooked on the fire. Likewise the burgers can be half cooked and kept warm so that they can be finally cooked up quickly.

Visit to

Time to visit somewhere or place. The list is endless. Check out the list suggested in the resource leaflet and choose those places that interest you. It will involve a bit of work before hand contacting people to arrange the visit so appoint a coordinator early. Don't forget a thank you note after the visit.

August

Camp games

This is the type of activity that can be organised for the Unit perhaps or for one of the sections. The Unit can get involved by setting up the event and by taking part in teams later in competition with the other sections. This activity could also be organised for Venturers only. You may also choose to run this activity during the day as most of the members of the Unit will be on holidays.



On Expedition

You don't need to have a meeting tonight as you will be on expedition for the next two weeks - won't you

Self defence / Cook a meal for 5 euro

Two items for tonight's meeting:-

Self defence

Invite a self defence expert down to the meeting to explain a number of self defence moves/ approaches. Or you could drop down to the nearest gym or martial arts centre. The exercises/ self defence approaches should be kept to a minimum and should concentrate on avoiding trouble rather than equipping you to take on the nearest gang of thugs. Special emphasis should be paid to self defence skills for woman.

Cook a meal for 5 euro

Each member of the Unit is given 5 euro a couple of days before the meeting and asked to devise a menu consisting of 3 courses or more. They must now buy the foodstuffs which must not exceed the budget allocation and cook the meal at the meeting. Each Venturer is responsible for cooking and eating equipment.

Menu's should be adventurous and not consist of bangers and mash. Award a prize to the best effort, perhaps a voucher for a meal for two in a local restaurant, they may even sponsor the activity.



September

Annual General Meeting

Every Venturer Unit should hold an Annual General Meeting of the Unit where the Unit can have a chance to elect officers for the coming year. There should also be an opportunity for any member of the Unit to propose changes in the rules of the Unit or suggest possible activities in the future. You may also use the opportunity of the Annual General Meeting to display the Unit to parents, friends and other members of the Unit, once the official business is out of the way. Perhaps even showing a slide show of the annual expedition or a round up of activities undertaken during the year.

Visit to the Cinema

After all the drama of last weeks meeting a visit to the cinema will allow you to have some fun and relaxation.

Kite making and flying / car mechanics

The meeting tonight is split over two activities. When was the last time you flew a kite, maybe you have never flown a kite, now is your big chance. Kite flying should not be taken lightly it requires quite a bit of skill to make and fly a kite. You may also like to keep an eye out in the local park for kite flyers, there are a number of clubs being set up around the country dedicated to kite flying who could help, they mainly fly stunter kites in formation. Great stuff to watch.



Certainly you should know the parts of an engine and how it works, and how to do the minor jobs necessary on a engine.

First aid incidents / Lateral thinking

First aid incidents - the object of tonights exercises should be to keep your first aid skills sharp. A few incidents should be set up, as with the last incidents the Patrol Leaders will be willing to act as victims. The incidents should be more complicated in set up perhaps involving the lifting of heavy weights or the lowering of victims.

Lateral thinking - Lateral thinking is the skill of transcending normal thinking methods so as to discover the solution to problems. The resource article will suggest how to set up this activity. It can be run just in the Unit or you may wish to ask along another Unit just to heighten the competition.



Do you know a spark plug from a brake pad or is inside of a car bonnet a mystery to you??. You should ask a local mechanic to lend a hand or perhaps a parent who knows what is what. It maybe useful to consult your old merit badge book for guidelines as to what you should know.

October

Third World night

October is usually 'One World Awareness' month and what is suggested for tonight is a Third World exercise which will explore the conditions that people in the Third World experience. A number of exercises are suggested on pages 48 and 87, which will help you to organise this activity. Perhaps the most important part of this evening should be the debate on issues raised in the exercises. This is the only way that the points of the exercises can be brought home to us in the developed world



Inter - Unit night

The activities organised for this evening should take the form of a Inter - Unit competition, set up in the most friendly of terms. Activities might include a general knowledge quiz or a challenge game - each Unit setting a challenge for each other in turn. The challenges maybe agreed before the night by the Leaders just in case gear is required. Each challenge should be capable of being completed in say 5 minutes.

Its radio night

Ever wanted to be a DJ or producer of a radio show or play, now is your chance. You will need a couple of tape recorders and a few mikes to get you going. You should try to be as professional as possible in your productions. You may even get some help from a local radio station or from the media studies department in the local V.E.C. college. Your Unit should aim to produce a radio music show, a radio play, and a radio ad.

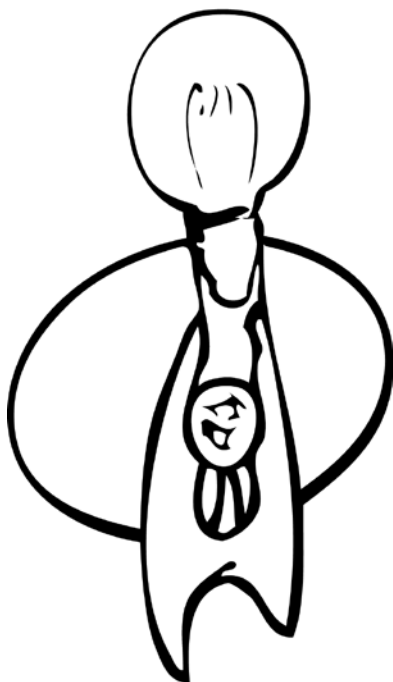

Wide Game

The Troop are always interested in taking part in a wide game. Earlier in the year you ran a wide game for the Troop. Now, using your own imagination create your own wide game for the Troop. A resource article on page 73 will aid you and prompt your imagination. The most important thing to remember is that the game should be won by teamwork and skill and not by force or strength. The finer details should be ironed out with the Court of Honour before the night of the activity.

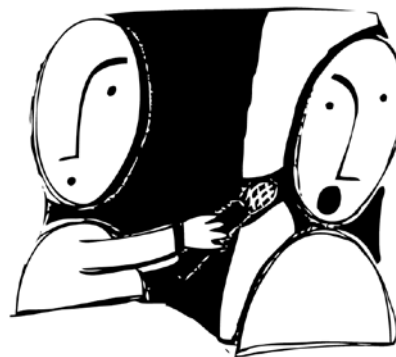

November

Leathercraft, woggies and lanyards

- do you know how to make them? Well now is your chance to find out and practice. See Scouting Trail for details. You will have to buy some equipment such as basketry materials and coloured braid or you could use leather thong.

Debate

A subject should be chosen for debate and allotted to two teams of speakers at least a week before to - nights meeting so that they can prepare their subject matter. The resource leaflet on page 100 explains how the activity should be set up and controlled. The activity should be a civilised affair and not result in a row or free for all.

Mock Trial

Do you know your rights? How do the courts operate? What is the role of the jury?. To - nights meeting is a role play exercise whereby you will assume the roles of the various officers of the court. You will try a case based on a set scenario (see resource leaflet). It maybe a useful exercise to hold a debate on Justice and the Law after the activity, or perhaps ask a member of the Gardai/ PSNI along to give a chat to the Unit.

Jamboree - on - Air / Advertising

Jamboree - on - Air is an international event that uses ham radios to communicate to our brother and sister

scouts world wide. In order to set up this activity you may wish to contact the International Department in N.O. who maybe able to help and supply contacts locally, or you could contact a local ham radio operator. This evening activity is based around ham radios -how to use them, what are call signs etc. Morse code is also used when communicating by radio and perhaps you could build a morse buzzer and practice sending messages (see Scouting Trail)

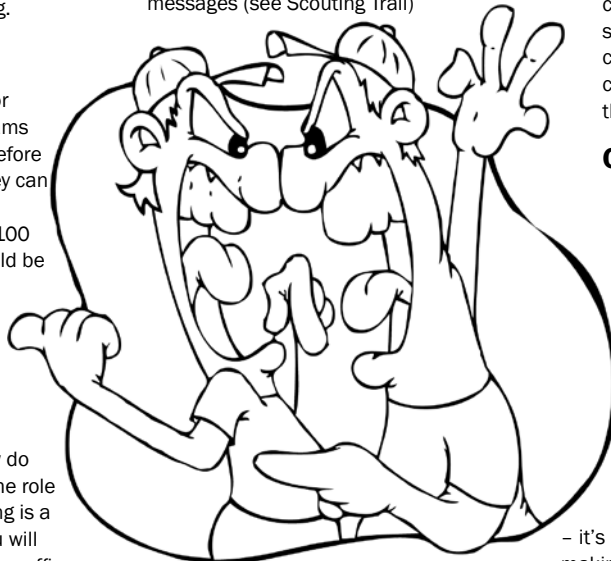

Advertising

What part does advertising play in our lives. Does it influence the way we buy things. Do we realise what messages are being presented or underlining advertisements. All these questions and more or up for exploration and discussion. It setting up this activity each member of the Unit should bring down a video tape of their favorite ad. Don't forget to organise a television and recorder to be brought down to the meeting for this activity.

Candle making / Computer Game Contest / Pottery

A collection of activities for to - nights meeting to cater for the needs of different tastes (not everyone is interested in computer games/Candle making maybe a money spinner for the Unit with Christmas only around the corner. Your local library can provide you with craft books which can enlighten you to the skills of candlemaking. A craft shop can supply you with materials or you may chose to melt down ordinary white candles and reform them or colour them with pieces of crayon.

Computer Game Contest.

Organise for someone to bring down a game console and find out who is the Unit champion.

Pottery

Like candlemaking, the local library can help with books and information. Once you have read up on the subject you should be able to put together an activity. It could be based on coil pots, or you maybe able to get a local potter to bring along a pottery wheel - it's not as easy as you think. Like candle making, materials are usually available in craft shops.

December

Money Management / Primus stove cooking

How do you operate on a budget? How do you manage a household? What is life like on the dole? What is the difference between a bank account and a building society account? Questions that should be answered before tonight's meeting is over. You will have to organise a speaker for this evening perhaps a member of the bank, a parent, an accountant, a person on the dole. The object of the activity is to present budgeting skills to the Unit and to make them more aware of the realities of life once you are away from the protection of your parents, in the big bad world.

Stove cooking

Cooking a meal on a camping stove can be a tricky skill to master when you have only one cooking ring. Don't wait till you are on the side of a mountain in driving rain to discover how to light a stove and cook a meal on it - practice makes perfect. You may wish to couple this activity with exploring and food testing some of the dehydrated meals which are now available.

Weather forecasting /The President's Award / Games of chance

Weather forecasting and understanding weather is a useful skills for everyone to know but it is particularly useful when on expeditions and activities in wild and open country side where the weather is subject to chance at short notice. As with other



ideas suggested in some of the meeting above a trip to the local library or web will always be of help. In fact our own Scout Manuals contain detailed information on the subject. This activity can be coupled with an exploration of star formation and a local astronomer can help.

The Presidents Award - what is it, can your Unit that part. Ask a local PAL (Presidents Award Leader) to talk to your Unit about it. The name of the local PAL can be had from your local V.E.C. Adult Education Officer or by contacting the Presidents Award Office.

Games of chance

Following on from last week's exploration of money Management set up some games of Monopoly, The game of Life or games based on the stock exchange

Christmas party

Do we really need to explain this activity

New years eve Party

Again, do we really need to explain this activity

Ideas for your Venturer Programme

Service Made Easy

SCOUT'S OWN - Plan, organise and present the Scout's Own Service at the next County Camp.

CAMPSITE FIX-IT - How's your Group/County Campsite? Huts need painting? Paths overgrown? Our mob donated and erected a flagpole.

SEND IN THE HEAVIES - So the Ladies Club is putting on a fete/fashion parade/old time dance, etc. . . wouldn't they love some hefty volunteers (including males).

VENTURER TRAINING - Rovers or Venture Scout who have done it before can help out at the next Initiative or Leadership Course. What unusual stunts can you think up? Obstacle courses and injured-parachutist-up-a-tree, behind-an-electric-wire-fence, etc. go down well.

IMAGE - Does your /Group/County have a Public Relations Team? Local newspapers love to receive articles on Scouting, especially with good photos. Does your local radio have a Scouting session.

TENDERFOOTS - You probably take all this outdoors stuff for granted. Run a camp for some kids who aren't Scouts. Be tolerant and helpful and maybe they will become Scouts!

B.P. did this on Brownsea Island and look what happened to him!!

SPORTS EVENTS - You can act as impartial officials at the next sports event run for Cubs or Scouts (or Brownies? ...). Give everyone a job; timekeeping, scoring, first aid, etc.

HAVING A BREAK - So the section leaders are having a well earned rest, and the kids are at a loose end for something to do. Of course your group are organising a camp or at least some activities to occupy the little darlings. Who's qualified to help with test work?

WORTH BOTTLING - Save a couple of lives by donating a pint each at the Blood Bank.



HAY FEVER - Next time there is a County Cub Day, offer to build a hay bale maze. Where can you borrow the hay?

STOP THIEF - Any decent electricians in your group? Ever thought of installing a burglar alarm in your Scout Hall?

DIG IT - The old Widow Murphy around the corner would love to have some weeding and mowing done. Tea and bickies guaranteed.

RE RUNS - Is your local Historical Society putting on some sort of re-enactment in the near future? Can they use some extras?

OVER THE TOP - Build a commando course for the next Scout camp, Pack Holiday, etc.

MOBILE MUNCHIES - Even if you only do it to see how the other half lives, lend a hand with your local Meals-on-Wheels Service.

JAMBOREES AND OTHERS - There are many county/national activities on which you can lend a hand. . . After all, you are in the Movement! Cooking, putting up tents, running activities, etc.

PACK! PACK! PACK! - Many charities send food parcels to the poor. Now's your chance to practice your gift wrapping try the Vincent De Paul.

DANCETIME - But what sort? Disco, Rock, Square, Ceile? Any other sort? Fancy dress makes it more interesting and cheaper. Don't forget soft drinks to sell to thirsty shapers.

THING-A-THON - Ever heard of the Scout Walkathon - Peak 2000? Or you could organise your own, or a Bike-a-thon, knot-a-thon, pram-a-thon, joke-a-thon, campfire-sing-along- a thon.

MEALS BETWEEN WHEELS - Progressive dinners, in case you didn't know, consist of each course being served at a different house, with the participants driving (or walking) between each locality and paying for the privilege of doing so.

GONE NATIVE - Plan a major expedition far from civilization.

OPEN ROAD - You don't have to go off the beaten track to have a hike. A casual ramble along a country road can be fun whether you only take one day or longer. How about taking the Scouts?

SWIMMING - Beach, pool or lake? And while you're thinking about it, when was the last time you rehearsed artificial resuscitation and heart massage?

SOMETHING FISHY - On river or sea. You could hire a boat. A prize for the biggest caught - then get a taxidermist to show you how to mount it.

RAFTING - You could race or just drift with the current.

CANOEING - No canoes? Rent 'em or make 'em.

CAVING - Or speliology to be more precise. Get in touch with a caving club.

DOWN ON THE FARM - Lend a hand on a farm for a weekend. Or if you're a country Group invite some city slickers up.

PROSPECTING - Get hold of a few metal detectors and spend the weekend searching. You probably won't find any gold, but you'll soon locate the rubbish

heaps behind the houses. Horseshoes, flat irons, antique bottles ...

GETTING YOUR BEARINGS - Practice your compass work, either in the hall or outside. Get one person to set out the bearings and places, and then each person tries it. See how many end up in the same place.

FOILED AGAIN - Have you experimented with foil cookery? What time does it take to cook various foods? It sure beats carting pots and pans on a hike . . . P.S. Try chocolate bananas! Yummy!!

HELP!! - Do you know the land-to-air rescue signals? How do you tell a passing aircraft that you need a doctor or other help? And what about Morse and semaphore?

SAILING - Visit the National Water Activity Centre in Killaloe

ROCKCLIMBING - Scramble your way to the top. Find an instructor.

LIFE ON WHEELS - Organise a bike hike. An old popular favourite, but make sure there's a lack of hills.

Life in the Open Air

GOLD PANNING - O.K., so maybe you won't find much, but at least you'll have a clean frypan.

MESSING ABOUT IN BOATS -Lots of groups use canoes and rafts, but what about the old fashioned rowboat? A lazy afternoon or a long expedition?

CORACLES - What?!? They originated in Wales as a light weight, circular, one-man boat made of skins stretched over wicker. Check out page 50 and make your own from whatever you can scrounge.

DARK WANDERINGS - Try a night hike as part of your next camp, or even a regular meeting night.

SURVIVE OR PERISH - Study techniques of living off the land, then run a survival camp eating freshly caught fish and rabbits, wild berries, fern tips. Make sure you know what you're doing!!! Don't eat anything poisonous will you?

GYPSIES - Don't just hike - travel around with a horsedrawn caravan. It's a great way to see the country.



Let's Get Physical

ARCHERY - Pop along to your local archery club and watch out Robin Hood. Why not try making your own bow and arrows?(see page 45)

SLIM IN THE GYM - Get the old iron pumping with a bit of weight lifting and other exercises.

MANY HAPPY RETURNS - Can you throw a boomerang?

WATER SKIING - Either get hold of a boat or a lake with a slope. Some instruction may be necessary if you don't want to kill yourself.

ABSEILING - jumping off cliffs with ropes. A bit of instruction and you can put on your own displays.

BURNING PAPER - Ever built a go-kart? Get your mechanical skills to work. Great fun.

TEE TIME - Well, you've never played golf with the group before, so give it a go. Challenge the parents.

WRESTLING - Arm wrestling? Leg wrestling? or the best of three lifts of the ground wins. Chuck in a game of British Bulldog for good measure.

MAKING A RAQUET - Try tennis for a change and bring a friend, or perhaps challenge another group to a game of Ping Pong or maybe Badminton.

GOING TO COURT - If you're really feeling energetic why not try a nice quiet game of squash. There's bound to be a squash court somewhere near you.

GEE GEES - Can you ride a horse without falling off too often? Give it a go. Maybe



you live on a farm and do it all the time. O.K., why not invite some city slickers up for the weekend. It's worth a chuckle.

VOLLEYBALL - A bit of skill and teamwork goes a long way but you should easily be able to scrounge the sports equipment.

CUNNING RUNNING - Try orienteering. Here you can combine your Scoutcraft skills with your wonderful physique.

ROUNDERS - Never played it? Try it on your next weekend.

TRAIL BIKES - Beg, borrow or hire a few bikes and try it out. Don't hurt the environment too much, please.

B.M.X. - Pinch your little brother's bike and hit the track. Can you stay on?

GERONIMO - Ever jumped out of a plane? Make sure you're wearing a parachute and not a pack. You'll need lessons, of course. Normally done for charity.

NIGHT DROP - A great activity with the Scouts too! Get yourself driven out into the middle of nowhere, then hike back in the dark. Hot coffee all round.

S.C.U.B.A. - Self contained Breathing Apparatus. Do you know how to use it? A good weekend, perhaps coupled with a bit of underwater photography.

ON TOW - What's parasailing? Find out about it and give it a go.

MISSILES - Caber tossing and javeline throwing and shot putting and discus throwing and . . . How about a Highland Games contest.

BECAUSE IT'S THERE - Mountaineering has its ups and downs. Don't attempt Everest until you've had some practice.

ON GUARD - The ancient art of fencing. That's with foils and sabres, not barbed wire, stupid.

SELF DEFENCE - Learn the basics on judo, ju-jitsu, karate, kung-fu, etc. You'll never know when you'll need it.

SHARP AND KEEN - Run a woodchopping event, before you have a campfire.

MONKEY SHINES - Try tree-climbing, with spikes, or a Marlin hitch. Any ideas for a competition?

COME AND DO - In teams of two, build one obstacle for a commando course. Then everybody gets a go at the whole course.

OLD FAVOURITES - Try something Medieval for old times sake; quarterstaff, jousting, horseshoes.

Inter - sectional Rivalry

WHAT'S COOKING - Challenge another Unit to prepare a three course meal. Invite a couple of professional caterers to act as judges. Set a theme like "French", "Chinese", "Vegetarian", Make it an annual event with a perpetual trophy.

SPY NIGHT - The Scouts are told there is a spy carrying secret documents in a brown paper bag somewhere in the shopping centre. They are told to discreetly follow him. They are not told that the Venturers are all in disguise and are passing the bag to each other at planned rendezvous points. Any more ideas?

CAR TRIAL - O.K., so Venturers can't drive, but they can navigate! Plan it well with cryptic clues, an emergency panic envelope and a barbecue afterwards.

SNEAK WEEK - Requires heaps of organising, bushcraft, stealth, compass work and skill in camouflage. The idea is that teams spend the week or weekend on some huge campsite, discreetly observing each other without being observed themselves. No contact allowed between teams, all the enemies movements must be noted. Perhaps extra points for stolen trophies?

FLOUR POWER - Have a flour bomb raid on the next Scout camp. But make sure you've talked it over with the Scout Leader first so that he's got lots of ammunition for the lads.

OLYMPICS - Challenge another Venture Unit or more to a games night. Volleyball, leapfrog, tug-of-war, basketball, stilt races, tag, etc.

SOCIALISING - Don't keep it to yourselves! Invite the entire County. A barbecue party?

STROLLING - Take the Troop or the Pack out for some exercise. A not-so-hard day hike is a great way to make yourselves know.

CAMPFIRE - Prepare now! Make up a few skits and learn some songs.

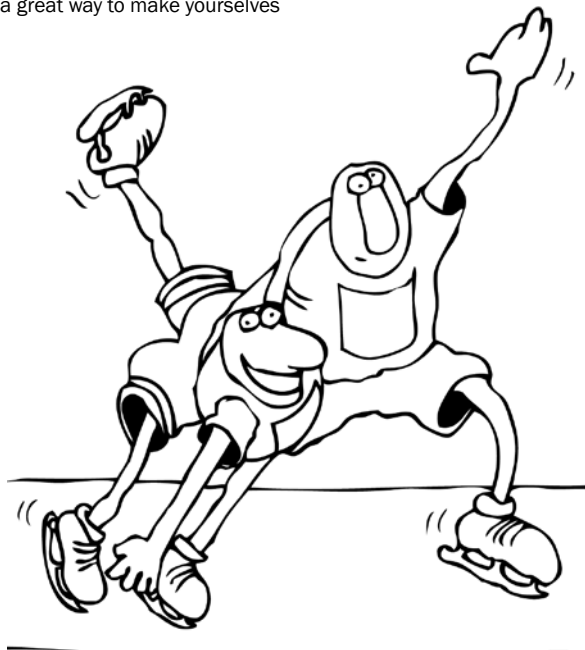

LOOK WIDE - The old-fashioned wide game always goes down well with the Troop. Be inventive, or do something simple like making the Scouts sneak up a hill undetected and put out a lamp.

FIGHTING MACHINES - Challenge them others to a no-holds barred, all-in, blood-and-guts game of tiddly winks, or chess for the faint hearted.

UNACUSTOMED AS I AM - Each person is given a set subject the week before the meeting and they have to give a five minute talk using any props and equipment he/she needs.

THE SMELL OF GREASE PAINT - Write, produce and perform your own play or concert before an invited audience. Doesn't have to be lavish.

MOVIE STARS - Get hold of a movie or video camera and make your own film. It could be a major project.

RADIO ACTIVITY - Hamming it up on the air waves is a lot of fun, especially during jamboree-On-The Air. How many International Scouts can you contact? Your local ham radio operator will be pleased to help.

Culture for Beginners

GONE POTTY - Get a local potter to teach you how to throw. Not as easy as you think.

CARVING - Start with soap and then try wood, stone, bone - woggles, trophies, chessmen, etc.

STICK WHITTLING - B.P. had a fine collection of carved walking sticks in the days when Scout staves were mandatory. How ornate can you get? Special attachments, secret compartments, built-in watch or compass . . .

WEAPONRY - Use your imagination and your pioneering skills to construct ancient warfare machines. Battering rams, catapults, swinging targets, or how about an automatic bellringing burglar alarm.

TAKE UP THY TENT - So you reckon your tents are pretty poorly designed? Could you do better? Verandahs, shelves, pockets, rain water gutters.

T SHIRTS - So you'd all like a Venture Unit T-shirt or windcheater? Get some transfer paper for your ink jet make up your design and print and iron.



SNAPHAPPY - What is the best sort of camera to buy? Which is most suited to your needs? Your photography expert would be glad to show you. How about a photo competition? There are regular competitions for the best Scouting photo run by the World Bureau.

WHAT MAN HATH WROUGHT - Ever tried wrought iron art? Can you use a welder? What are the pros and cons of blacksmithing?

DIM WICKS - Candlemaking can shed a bit of light on your imagination. Paraffin or Beeswax? Scented? Tapers? Shapes? Colours?

WHAT KNOT - So you're an expert knot tyer, eh? Could you make a macrame wall hanging or Hammock?

HIDE AND SEEK - A few hours of practice at leather craft and you'll be making your own belts, wallets and woggles.

KITE MAKING - Hold a competition. Use natural materials or scraps. Can you get it off the ground?

MOVE OVER PICASSO - Try portrait painting or landscapes. Pen and ink, pencil, oils, charcoal, fingerpainting, and water colours are all worth thinking about. You may like to have your own exhibition, with all the trimmings of course.

HOW'S TRICKS - Conjuring is a legitimate art form. Each member learn to devise a few simple tricks and then put on a show for the Cubs?



FURNISHINGS - Design and construct those things which you have always needed for the den, but never got around to making them: bookshelves, cupboards, waste paper baskets, etc.

Surviving Your Environment

NATURE TRAIL - How many types of tree, plant, insect, etc. can you identify them .

WATCH THE BIRDIE - Get up early and listen for the dawn chorus. Why not use tape recorders?

WOMBLES - How is pollution affecting our environment? Look around you. What is being done about it? What is your Group doing about it?

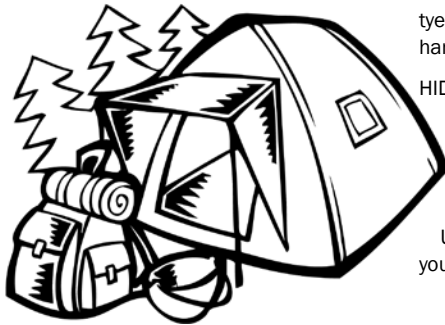

THAT-A-WAY - What do you know about celestial navigation? Can you use a sextant? How many constellations can you name and recognise?

DIG DEEP - Find out about archaeology. Get a guest speaker or visit the museum. Perhaps a good service project would be helping at an archaeological dig.

LOST SOULS - Train yourselves in survival skills - crossing rivers, exposure treatment, snow shelters, signalling for help etc.

ON THE HOME FRONT - Make sure everyone can cook forty or fifty basic foods - eggs, potatoes, porridge, meat, etc.

Ideals for All

EVERYTHING YOU WANTED TO KNOW ABOUT SECTS - You are planning a weekend camp consisting of one Muslim, one Jew, one Roman Catholic, one Seventh Day Adventist, one Protestant, etc. Plan an appropriate menu and programme, allowing time for individual services.



COUGH! COUGH! - Is smoking smart? Why do young people smoke? How do you stop?

BOOZE AND DRUGS - Get someone to come along and talk about drug abuse. You'll be unpleasantly surprised.

LET ME IN - Here's a thought provoking discussion topic suppose they dropped a bomb and you had a fallout shelter big enough to house all the Venture Unit except three' Who do you leave out? Which individuals can contribute the most to your survival? You would only have ten minutes to decide before the fallout started ... a hard one!!!

Crazy Things for No Reason at All

MEALS ON WHEELS - Cook an omelette or pancakes in a wheelbarrow while being pushed around the block.

KIDS NIGHT - Have a children's party for adults; party hats, jelly, ice-cream, 100's and 1000's sandwiches pin-the-tail on-the-donkey, blind man's bluff . . .

APPLIED LUNACY - Try erecting a tent on sand. Try lighting a fire underwater. Try cooking an egg in a paper bag. It can be done - think about it.

COME INTO MY PARLOUR - Get a library book on parlour games. Charades, twenty questions, sardines, is that your Moriarty?, Guggenheim, consequences....

SKYSCRAPERS - The business part of the meeting will be conducted up in the rafters of the hall. You'll need seating and a writing table. A good test of initiative and pioneering skills.

DING A LINGS - Can your Venture Unit fit comfortably in a phone box? We always eat our pizzas in one if it's raining.

JUST TRY IT - Design a mouse trap to catch only white mice. Slam a revolving door. Walk on water. Have a fight in slow motion. Try not to think about polar bears.

PLEASE DROP A LINE - Send a message in a plastic bottle attached to a bunch of gas-filled balloons and eagerly await a reply.

CHAMELEONS - Could you camouflage yourself? Your campsite? I once fooled my leader by pretending to be a pile of packs and raincoats.

LILLIPUT COOKS - What's the quickest time you can boil six teaspoons of water in an eggshell using a fire built of matches on three 2 euro pieces? Can you cook sausages on a coathanger over a candle?

SAND CASTLES - why not run a sand sculpture competition on a local beach.

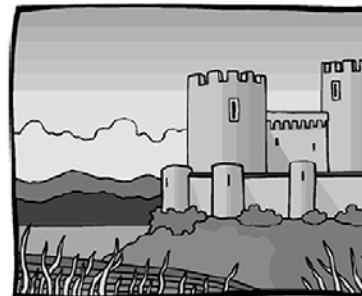



WILD WEST - A quick draw gunfight using water pistols. A lassoing contest. Bronco riding (but how do you build a horse?).

TRANSVESTITES - Organise a change of-sex night (without warning). Girls help the boys with make-up, then bring out the camera!!!!

CRASH AND BASH - Next time there is a fete, Scout Display etc. get hold of an old car destined for the tip. Hire out sledgehammers at 1 euro a minute. Make sure you clean up afterwards . . . by the way, do you know the world record for piano smashing.

CHARCOAL COOKING -Experiment a little. Spend an evening at it, then use it at the next weekend away.

SCOUT LAWS - Of course you know them. O.K., then, what's the Fifth one? Or the Seventh? Discuss them.

NIGHTBEAT - Start at dusk, finish at dawn. Organise visits to places open at night. Hospital, Garda, docks, airport, etc. Finish with breakfast at the wholesale fruit or fish market. Needs a lot of organising and coffee.

MONEY MONEY MONEY - Get expert advice on budgeting, borrowing money, bankcard, taxation, hire purchase . . . What are the pitfalls and advantages?

PERSUASION - Is advertising ethical? What are the tricks of the trade? How can the Group use them for recruiting

FREEDOM - Be prepared for the outside world. Can you cook a decent meal? Have a shirt ironing competition.

HOW DO YOU TICK? -Transactional analysis? Group dynamics? Personality clashes? Peer group pressure? What!?!

POW! WOW! - Tired of the old tent? Pop along to the library or get on the internet and find out how to build a genuine Indian tee-pee. It would look great on your next big camp.



Creative thinking

Generating your own ideas

As Scouts you will work in teams - a Patrol or Unit. The game of Scouting will challenge your Unit in every way both physically and mentally. The Team will be presented with many problems to solve and the solution to these problems will involve team work, leadership and creative thinking.

Creative thinking involves using a number of techniques which will enable you and your Unit to think in new ways and be more effective as a team.

There is nothing more excitingthan thinking of a new idea

There is nothing more rewarding....than seeing a new idea work

There is nothing more useful...than a new idea that helps you meet a goal

Creative thinking comes about by having the ability to create new ideas by accidentally or deliberately joining two or more unrelated ideas, thoughts or concepts together.

Thinking

Humans are naturally lazy and will generally not push themselves beyond what is necessary. So most people are happy to limit their thinking skills. 'That's impossible', 'I can't do that', 'I give up' are statements we are all fond of and say when we are confronted with tasks and thinking which requires effort. Nothing is impossible, it is only so because we can't think of a way to make it possible. By

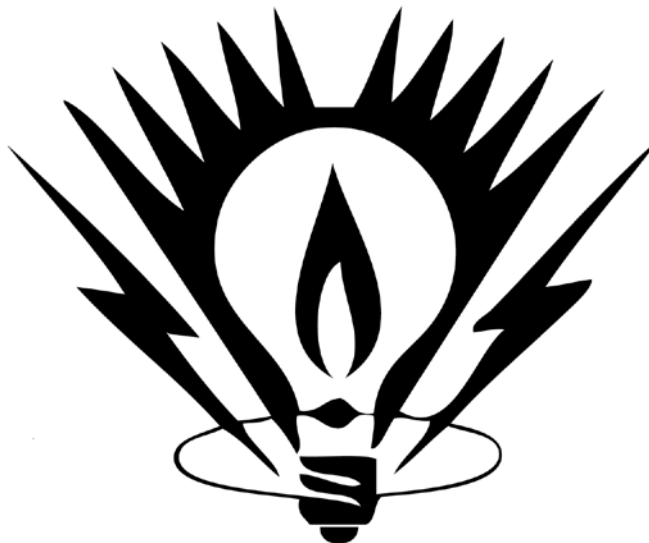

forcing yourself to think in new ways many alternative approaches and ideas can be generated to solve the same problem.

The brain divides its thinking into two forms left hand thinking and right hand thinking. The left hand side of the brain controls most of our thinking and tends to dominate it. The left hand side of the brain controls logic, calculations, analysis, ordering facts and figures whereas the right hand side of the brain controls music, colour, art, scale, rhythm. Generally speaking the right hand side of your brain tends to be more creative in your thinking process and can visualise and connect ideas that the left hand side may reject as 'impossible'. This is often the case when trying to solve a puzzle or code. The left hand side rejects the coded message as impossible because it does not recognise the language or sequence of letters. The right hand side however can visualise a language which uses numbers instead

of letters and so may provide alternative thinking . The solution therefore is a combination of left and right thinking. As the left tends to dominate, it is often hard for the right to create new ideas and so we give up, but by working at it a little longer the left will recede so that the right can dominate and supply new thinking.

Group thinking

Thinking creatively is best done with others. Each member of a group can contribute an idea and the pool of ideas will spark other ideas in the group - this technique is called brainstorming. During a brainstorming session, ideas are contributed no matter how mad or wild for a short period of time. Each idea is then assessed on the list for workability etc. and finally a number of possible ideas are explored.

Another good method is daydreaming, best done in a tent late at night or sitting

around a campfire. Everyone is allowed to contribute their wildest daydreams - 'wouldn't it be great if....' or expand on or explore other peoples ideas. It is normally best to stick to a theme or subject to get best results. When daydreaming try to image what it would be like in reality, by doing this it is often easier to see how it can happen in the future. There is a famous quote which goes along the lines of 'If you can dream it, you can do it'

Refining

Coming up with an idea can sometimes be the easy part making it work is the hard part. There are a number of ways of refining your thinking so that you have a clearer understanding of what has to be done to make it happen. Edward De Bono a famous thinker and creator of a number of thinking techniques uses a method called the Six Thinking Hats. Each hat has a different colour and when your are wearing or using this colour hat you only think in a particular way for a set period of time. By using this method it allows you to drag apart and explore an idea to the fullest and perhaps create new and more exciting ideas in the process. The technique is controlled by a leader who suggests the use of each thinking hat in turn - everyone thinks the same way - and monitors and takes notes of ideas and suggestions. The process can take time at first but as you practice the method your speed of processing a idea will improve.

White hat

This covers facts, figures, further information we need, gaps in knowledge. The object in using this thinking hat is to assess what we know and what we need to know to make the idea work.

Red hat

This covers feelings and emotions. The object is to find out 'gut feelings' on an idea will it work is it a good idea etc.

Black hat

This directs thinking in judgement and caution. It won't work because...., if we do this we are in danger because...., it is a stupid idea because... Thinking in this area should always be logical.

Yellow hat

Yellow hat thinking is positive. The object is to explore all the positive benefits and results that an idea will have.

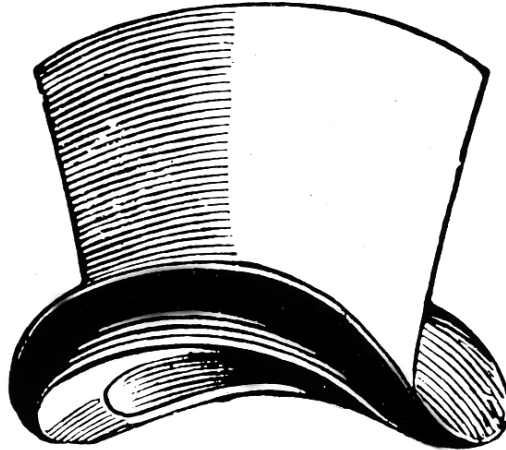

Green hat

The green hat is the creativity hat. The object is to change, add too, expand, 'it would be interesting if....' To think of other ways to make the original idea better.

Blue hat

The blue hat control the overall process. Have we explored all the possibilities for this idea. Do we need to revisit a coloured hat again to review what we have done.

By using this process you should end up with a new idea that has been explored and can be used. As you work in your Unit on a weekly basis and on activities, adventures and challenges you will become a collective thinking unit that will be able to create new ideas and solutions to better enhance your Scouting.

In your personal life learning how to think creatively allows your mind to expand and increase your capacity to learn and explore.

Lateral Thinking

Edward de Bono first coined the phrase 'Lateral Thinking' to refer to the process of thinking that is different from the normal trends of thought. In traditional reasoning, we progress logically from one step to the next. However, in lateral thinking, you must abandon normal thinking to eliminate inherent inhibitions and create new creative ways of thinking and solving problems. The sample problems listed below will at first seem unlikely and in some cases illogical, however, if you approach the problem taking into account the set of circumstances that describe the situation carefully you are half way to solving the problem. In completely solving the problem it will be necessary in a number of cases to make giant leaps of imagination in order to solve it. The solutions when presented always make sense. We illustrate 3 problems here but it is possible to find hundreds of problems of this type on the web - search lateral thinking problems.

Creating the environment

The best way to set up this exercise is to form a number of teams such as for a quiz game. The leader or an appointed Quiz master should then present each problem to the teams. This can be done by either reading out the problem or giving each team the problem typed or written on a card. It is sometimes better to present the problem on a card as the teams will want to read a problem a couple of times to examine the fine detail. If you have access to an projector you could also present the problems in this way. The quiz master can

then offer a number of clues or directions of thought to the teams if they appear to be perplexed after a number of minutes after these initial clues are presented the quizmaster should limit their answers to a YES or NO response. In order to achieve the answers to a number of problems in one session you should limit the time for a solution to a particular problem to say 10-15 minutes. Marks can be awarded to teams who come up with a logical explanation to the problem even though it may not tally with the answer suggested.

Sample problems

The man in the lift

A man lives on the tenth floor of a building. Every day, he takes the lift to the ground floor to go to work or to go shopping. When he returns, he always takes the lift to the seventh floor and then walks the remaining flights of stairs to his apartment on the tenth floor. Why does he do this.

Clues

Is there anything that he does between the seventh and tenth floors other than climb stairs
If he had someone else with him, would they both get out at the seventh floor and walk up to the tenth floor

Answer

The man is a dwarf. He can reach the button in the lift for the ground floor, but he cannot reach the button for the tenth floor. The seventh floor button is the highest he can reach.

Bombs away

One night during the Second World War, an allied bomber was on a mission over Germany. The plane was in perfect condition and everything was in working order. When it had reached it's target, the pilot ordered the bomb doors opened. They opened. He then ordered the bombs released. They were released but the bombs did not fall from the plane. Why should this be so?

Clues

Would the fact that the bombs did not drop surprise any of the crew
Was the manner in which the plane was flying the cause of the bombs not dropping

Answer

The bomber was flying upside - down

The Coal, Carrot, and Scarf

Five pieces of coal, a carrot and a scarf are lying on the lawn. Nobody put them on the lawn but there is a perfectly logical reason for their being there. What is it?

Clues

Does the time of year matter
Were the items brought out to the garden by human beings

Answer

They were used by children who made a snowman. The snow has now melted.

Outdoor Activities

The answer to the frequently asked question, 'what makes Scouting different from other organisations?' is, in two words, outdoor activities. We look for adventure, and we find it in the hills, the sea and the sky. Indeed, there is not much point in becoming a Venture Scout if you are not drawn by the prospect of adventure in the company of like-minded companions.

In the open air you come face to face with situations in which your physical self is all important. It may be that rock climbing does not appeal to you but one of the great features of Venturing is that it allows its members to choose their own activities and this applies to outdoor as much as to the indoor activities. Again, there is no shortage of pursuits to choose from. If rock climbing is not for you, select photography or anything else you like. Somewhere along the line, there has got to be some give and take. You are, after all, a member of a Venture Unit, and you have to build a programme that will entertain, satisfy and instruct all the members. So, if something on the outdoor programme does not appeal to you, orienteering perhaps, try not to turn up your nose and decide not to go that weekend.

Take a more positive line. Show a real interest, or, at least, approach it with an open mind and you may very well find that orienteering begins to stir your



imagination and creates the urge to find out more and take your interest further. Planning a programme to take account of all individual tastes is far from easy. The enthusiasms of some are met with the yawns of boredom from others. The best way of catering for most of the Venture Units needs is to have a programme which has regular summer outdoor meetings for everybody and extra meetings for those with other interests, in that way, everyone will get a fair crack of the whip.

Pleasing everybody

There is, of course, a way of pleasing everybody. Camps and expeditions contain just about every ingredient or appeal and nobody gets left out. But, here, we are concerned with outdoor activities in the ordinary programme setting. In deciding which outdoor pursuits to choose in, say, the autumn period, it will obviously need to find out from everybody what they

would like to do. First, they will suggest a mixture of already popular activities. Next will come new ones which they would like to try and others will be chosen to help towards one of the awards. With the ideas in hand, the Unit will be able to put together a worthwhile forward-looking and adventurous programme of outdoor activity which will, over a four month period, involve everybody at some time or other.

There is no need, of course, to follow a regular time-table in these activities, meetings, say, at a regular time once a fortnight. Therefore, three hours orienteering might be followed two or three weeks later by a whole day of rock climbing on crags forty miles from home. A few weeks later, a weekend's compass and mapping exercise with a night of lightweight camping can meet several purposes and make a worthwhile expedition in itself. And, as a bonus, there is added variety. You must be thoroughly trained in all the activities you choose to

do, whether they are simply for interest or steps towards an award. In a typical Scout Group and perhaps in your Venture Unit, there will not be people who are expert in everything. There may be a competent rock climber or canoeist, there may be a sub-aqua enthusiast or someone into archery but you will not have them all. If who want the right information and training find the right people and the right courses.

How do they go about this?

The first person to consult is the Venture Leader. He/she may have first hand information, know the right courses to look for or can point you in the right direction. Such courses are not usually expensive, but assistance can sometimes be obtained from your local VEC. The main organisations and governing bodies also arrange introductory courses to their sports and arrange the kind of courses you will be interested in. The number of clubs, organisations and societies which can help your Venture Unit towards a more adventurous outdoor life is very great indeed, and the more you look, the more you will find. If you want to do well in your chosen activities, you will need expert help from people who have trod the same path before you. Find the organisations which can help you, join and ask the experts for guidance. Without it, you will not get far, and without progress, you will not develop your enthusiasm.

It is, of course, vital that you have the right equipment for the activities of your choice. Every keen rock climber wants a good belt, climbing rope and rock boots, and he/she will get them somehow, no matter how great the effort needed or the price asked. Similarly, a Venture Scout whose

imagination is captured by the white water of a swift river will, before long, start to build or save up for his/her own slalom canoe. But there is, as we all know, a limit to what each individual can afford and the time will come when the Venture Unit has to step in and acquire a selection of good quality outdoor equipment.

The Venture Unit should draw up a list of priorities, asking itself which activities the Venturers are most interested in. Most things that are done out of doors, necessitate some gear. It is a case of deciding what should be bought first and how is the money to be found?

Equipment

There is a minimum list of equipment which any self-respecting Venture Unit

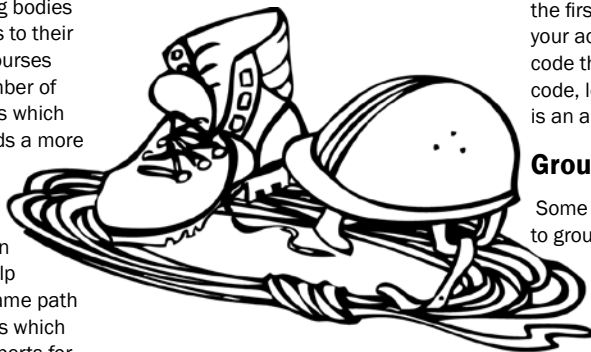

should maintain. It will include good standard compasses, a wide range of Ordnance Survey maps, climbing ropes, every kind of modern camping equipment and tools like axes and saws. If the Unit really specialises in canoeing or skiing, for example, it will build up its own fleet of canoes or a mountain-resort's worth of skis, sticks and even boots.

But what do you do if everyone is keen on something that is both new and expensive

to take up? Then start first with try out weekends and events. Normally, you pay a fee and equipment hire is included.

Venturer Scouts should take a proud, professional interest in their personal and Unit equipment, making certain that it is the best, safest and most reliable for its purpose. It must be realised that adventure involves risk. There is a greater danger from falling off a cliff than from a chair in the kitchen. But risks can be minimised by learning and respecting the appropriate safety precautions. They are drawn up for your benefit and ignoring them jeopardises not only your life, but the lives of those who would turn out selflessly to rescue you. To go on mountains in foul weather, badly equipped, unprepared for danger and ignorant about the safety rules is worse than stupid; it is selfish. So, the first thing to do when you have chosen your activity is to see if there is a safety code that governs it. Then get hold of the code, learn it until it is really familiar. That is an absolute priority.

Group Activities

Some activities are best suited to groups rather than individuals,

Your Programme should be wide and varied to attract all the members to participate and open up new opportunities to all. In choosing your activities, be realistic as well as adventurous.

As a Group, choose activities which everyone is interested in or, at least, prepared to try; choose things you can afford to do or for which you can find the resources. Activities which will not involve travelling long distances before they can be started are obviously more economical. Finally, make sure you can get expert advice.

As an individual, you should select activities which appeal strongly and are likely to become long term hobbies. Again, make sure you can finance them somehow. Pursuits that you can tackle alone or with a small group can be followed up whenever the enthusiasts want to get on with them.

Outdoor activity opportunities

High land adventures

Abseiling
 Bouldering
 Caving
 Fell running
 Ice climbing
 Mountain biking
 Mountaineering
 Orienteering
 Pony trekking
 Rock Climbing
 Search and Rescue exercises
 Hill Walking
 Snow activities
 High level camping

Water adventures

Bird watching
 Boardsailing
 Bridge building
 Canoe building
 Canoeing
 Fishing
 Gorge and gulley trails
 Raft construction and rafting
 Rowing
 Coracle building
 Rubber rafting
 Sailing
 Swimming

Night adventures

Night hikes
 Star trails
 Wide games
 Backwoods cooking
 Night navigation
 Bivouacking
 Wild life spotting
 Orienteering



Low level adventures

Archery
 Backpacking
 Cycling
 Farming



Forestry
 Horse riding
 Obstacle courses
 Pioneering
 Camping
 Survival hikes
 Tracking
 Environmental projects

Ocean Adventures

Coastal hikes
 Fishing
 Island survival
 Life saving
 Sailing
 Dolphin and whale spotting
 Diving
 Snorkelling
 Beach combing
 Bird watching

Archery

If you think of archery as a big bull's-eye on a bale of straw with archers trying to get the arrows to hit the target area, may we present an exciting alternative. Action archery is far more fun than conventional archery and allows everyone in the Unit to get involved.

A contest can be as simple as putting a few plastic detergent or milk cartons around a clearing in the woods. Try to locate the plastic jug bottles so that there is open ground or a bank behind them for safety reasons as well as preventing your contest turning into an 'arrow hunt'. The participants can warm up by blasting a few jugs and billies on the practice range before they go on the trail. The practice range also gives the shooters something to do while they await their turn on the trail.

A few difficult shots along the trail from a tree crouch or between a couple of boulders will add to the fun. Before placing any of the containers make sure that they are thoroughly cleaned. Each container should be pegged to the ground or tied to a branch to avoid the target blowing away and being knocked off its spot as it is hit.

Equipment

A couple of bows and a dozen arrows will do for a Venture Unit. These bows could be brought in a sports shop or each Venture Scout could make their own - which is much more fun. Arrows should be of the blunt type - better still with rubber tips. If your Venture Scouts are making

arrows then the tips should be protected by taping the tips with a small ball of masking tape.

The targets should be made from plastic containers. It is best to use the type of container that has a handle. By using this type it allows you to tie on to the handle easily when tying to a peg. You may want to have each station numbered on a sheet of cardboard. A number of pegs will be needed both to peg the containers and also to use as the shooting spot markers.

Scorecard and rules

Observe all regular safety precautions even though rubber tipped arrows are being used. Go over the trail in pairs. Shoot three arrows at each location. Keep one foot touching the shooting stake (or spot if it is a tree). When there are more than one target or more than one shooting stake, one arrow is shot at each target or from each shooting stake. Score 10 points for each hit. Verify your opponents score.

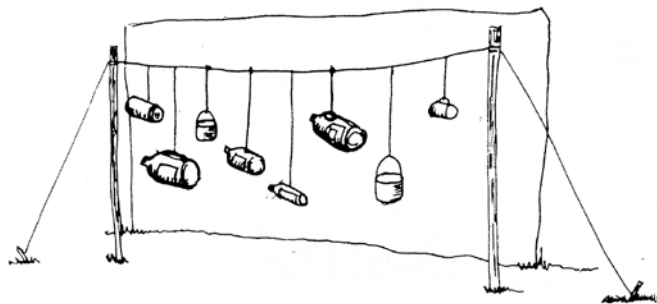
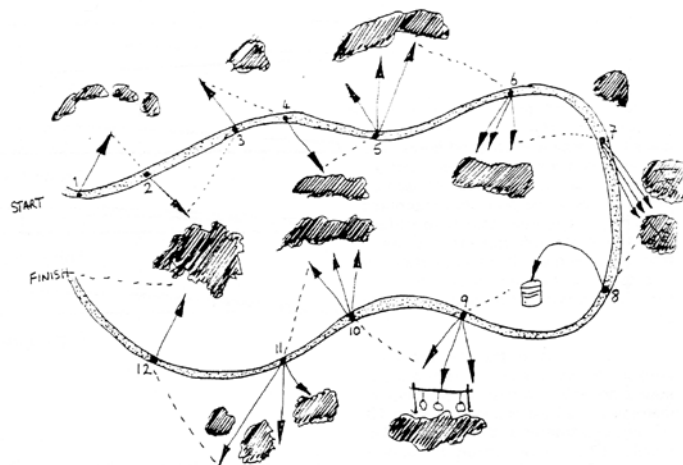

How to lay out a course

Select an area where there is a lot of scrub ground comprising trees, bushes open spaces. Mark out a trail with sisal or coloured binder twine. Place the shooting locations and shooting stakes on alternative sides of the trail. Make the shoots easy at first increasing with difficulty as the trail progresses. Use empty plastic bottles and milk cartons for the targets. These targets should be hung from tree branches, poles and stakes in such a way as they resemble a hunting situation from behind trees or through openings as you stand with your foot at the firing stake. See that no target is in the line of fire of any other target. Add a variety by setting three targets at different distances from one shooting stake (No. 5) and one target to be shot from three shooting points (No.10). At the entrance to the trail set up a shooting gallery with a tarp or plastic backdrop for practice while waiting.

Supervision

Although the archers bypass the trail at many points the complete trail is necessary because it provides a safe passage in both directions. Archers waiting to use the trail may practice at the shooting gallery to perfect their skills. Naturally, control of the gallery to allow for the safe recovery of arrows is essential.

Safety

Safety should be the concern of all. No messing of any kind should be tolerated. The trail should be set up as illustrated and in such a way that arrows are being shot into waste ground rather than across the trail or into another target area. Teams should be small, ideally two people but certainly no bigger than four. Before



anyone is let on the course the Leader should set down guidelines for the course.

These might include:-

- Everybody not shooting must stand behind the person taking the shoot.
- Nobody should approach the target until all archers have fired at the target.

Under no circumstances should an arrow be fired into the air. It can be seen going up but once it turns it is impossible to see it as it descends to earth.

All arrows should be blunt and have rubber stoppers on their tips or protected with masking tape 'ball'

The forearm of your arm holding the bow should be protected from the recoil of the bow string. A piece of cardboard or plastic wrapped around the forearm will do the trick.

Making a bow

The finest wood for making bows include ash and yew. However, hazel and birch poles have also yielded good bows. You should seek out a seasoned pole not a freshly cut branch. A straight stave that is free from knots and small branches should be selected, and the stave should be carefully cut with a saw and not broken off.

The measurement of the bow will vary with the available supply. The best diameter is from 40 -50 mm in diameter at the handgrip. This should be determined before the bark is removed. The length

should be approximately 120cm, but this will vary according to the height of the user. A good method of determining length is for one to hold the stave on a horizontal plane extending from the left shoulder to the tip of the fingers of the extended right arm.

The process of shaping should be done with care. It should be a gradual process rather than a method of hacking away the unwanted wood. Place a light scratch on

the stave where the hand grip will be and start to pare down the upper half of the bow to the tip. When one side is done then trim down the other side comparing the taper as you go. The circumference should be kept as round as possible from the handgrip to the tip. Testing can be done by slightly bending the bow at intervals and judging its strength or stiffness by sight and weight. A good bow will look good and will be graceful and light.

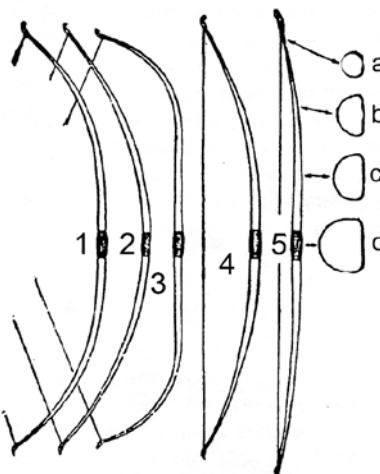
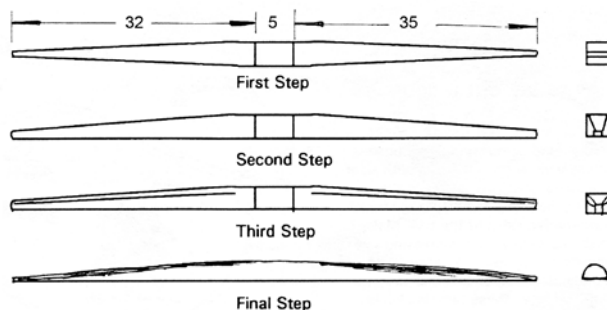

1. Correctly proportioned bow. The perfect bow is a trifle stiff at the centre, and the lower limb is a shade stronger than the upper.
2. Incorrectly proportioned bow. Bends in the centre.
3. Incorrectly proportioned bow. Too much bend in the mid - limbs
4. A well proportioned bow when braced
5. A good bow at rest. Slight following of the string is not objectionable.
6. Cross sections

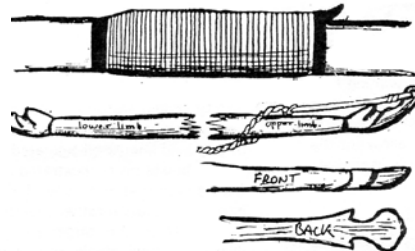

Paper Bag exercise

understanding the life of people who live on the streets of Calcutta

This exercise is a simulation game which will help participants to gain an insight into how poor people of India cope and survive on the streets of Calcutta. You will need lots of paper and tokens to represent money - each token is worth half a rupee - 0.5R. Participants are broken up into 'family' groups of 4 - 5 people.

In Calcutta many families live on the pavements because they can't afford to rent a one-roomed shack in the bustees. The children have to find, or create, work to survive; one means of doing this is paper-bag making. The children tear up old exercise books or use newspapers to make the bags, which they then sell to shop-keepers or street vendors.

Tell the groups that: "They are families living in the bustees of Calcutta. They have no permanent jobs, and there is no social security, but they earn their living by making bags from scrap paper. Many families are involved in bag-making, so competition is fierce."

"Bags are made by folding and glueing." Demonstrate how to make one. (You will need to practice first!) and give out the sample bags.

"Bags can be sold in batches often to the shopkeeper" (the group leader).

"The going rate is 5 paise per bag, therefore you have to make 20 bags to earn a rupee."

"Any sub-standard bags will be rejected by the shopkeeper."

Prices in Calcutta

Food:

1 kilo vegetables	2.00
1 kilo rice	3.00
1 doz eggs	6.00
1 lt. milk	2.00
1 kilo flour	2.00
1 whole chicken	20.00
1 kilo ghee (butter)	30.00
6 oranges	2.00
6 bananas	1.00

Sundries

Daily newspaper	0.50
Bus Ticket	0.30

Clothes

Trousers	40.00
Shirt	30.00
Cheap sari	25.00
Cheap sandals	10.00

Medicines

Doctors fee	4.00
Asprin (each)	0.05
50 antibiotics	5.00
Cough bottle	1.00

Other goods

Blanket	40.00
Monthly rent (bustee)	50.00
Primus stove	50.00
1 lt Paraffin	2.00
Saucepan	15.00
1 Kilo soap	10.00

How to Play

Groups work for 20-30 mins., depending upon the size and interest of the group.

They bring batches of 10 bags to the shopkeeper and accumulate their payments.

At the end of 'work' time, hand out worksheets. They are to add up their payments, and work out how much they could earn in an average day.

They must then work out how they would spend their 'wage'. Put the price sheet up on the wall. As a rough guide an adult in Calcutta would need daily:

Rent - 1.50R

Half kilo rice - 1.50R

Half. kilo vegetables -1.00R

Fuel for cooking - 1.00R ,

This would be enough for two meals

Extras

A cup of tea 0.50R

Some fruit 1.00R

Basic daily expenditure is therefore 6-7R per person. A family of 4 will therefore need at least 25R a day. But this is the bare minimum for survival.

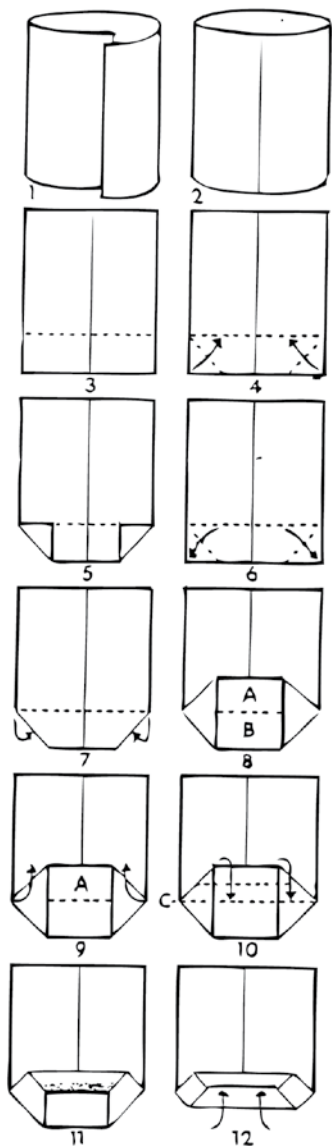

How to make your paper bag

- Fold the paper to the middle. Glue one edge and stick down.
- Flatten bag. Turn up bottom edge about 5 cm; crease as shown and unfold.
- Fold up bottom corners to the crease, press down and also unfold.
- Tuck the corners up inside the tube. Now you have a bag with two flaps, A and B as in stage 8.
- Fold back the upper flap 'A', and then fold down on itself to the middle line.
- Put some paste on the edge of flap 'A' as indicated by shaded area in stage 11.
- Fold up the lower flap 'B' to the overlap with glued area and stick down.



Worksheet

No. of bags in 10 mins

No. of bags in 1 hour

No. of bags in 8 hr day

Number of bags @ 5 paise

Going rate: 5 paise per bag
(100 Paise = 1 Rupee)

Discussion

First find out which groups survived and which did not produce enough to survive.

How did the groups organise themselves? Did those that produced the most bags work more as a team, one folding, one glueing, etc?

Did any groups help one another? How did the groups find the shopkeeper? Was he/she fair? Why is he/she powerful? Who are the equivalents in our society?

If there was no social security in Ireland, could we make paper bags? Could we sell them locally?

What could we do?

Can the group think of any products that we could usefully recycle?

The Coracle

-traditional water craft

The coracle is a traditional water craft used for centuries by rivermen fishing salmon. It was particularly popular on the Boyne where the last known coracle was used. It is an excellent and fun filled activity for Venture Scouts and its backwoods element certainly makes it a scouting skill worth possessing. They can be simply built in one day or two days if you want a more permanent craft.



The picture shows traditional Welsh coracle circa.1890. This craft is built using ash lathes and covered with cowhide.

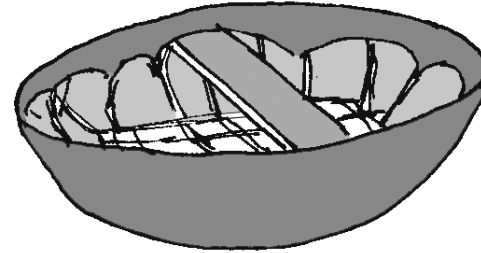
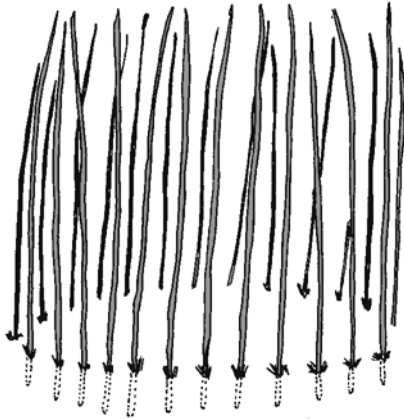

The coracle is created by making a frame and then covering it with a tarpaulin sheet or heavy plastic sheet which is stretched over the frame and secured to the inside of the craft.

The frame of the coracle is constructed using 32 hazel or ash rods about 25mm in diameter. The rods are pushed into the ground to create a 2 metre by 1.5 metre frame. The idea is to create a basket about 50cm high. When the frame is created place rocks or a heavy weight on top of the frame to keep it in shape over night.

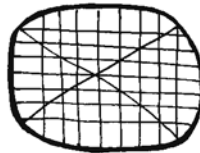

Bend over the rods to create a basket shape. The rods need to be tied together first before trimming the overlap. Don't trim straight away but rather wait until the frame is correctly shaped. The trimming needs to be done carefully so that there are no burrs that may damage the skin of the craft



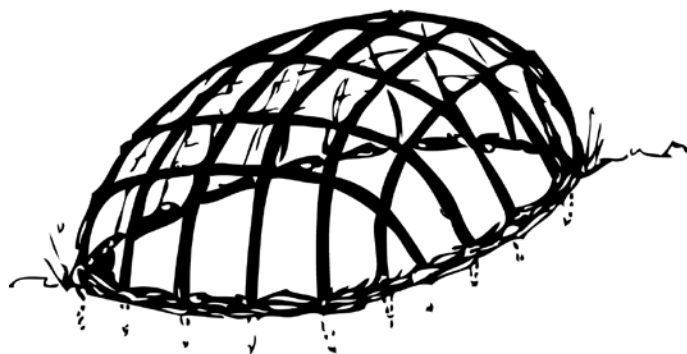

When the frame is complete check it for any sharp edges. Trim these and sand down if necessary. Place a simple lashing at each intersection of the frame, this helps to hold it together. When you are happy cut the frame away from the ground rather than pull it out of the ground. This action prevents the frame from being damaged. Secure the interlacing binding and fix in the seat. Be happy that the frame is sound before drawing on the over sheeting.

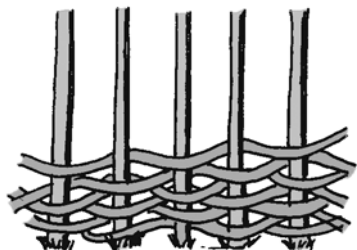

An interlacing binding is woven around the base of the rods before the frame is removed from the ground. This needs to be about 100mm deep and constructed using light willow or hazel rods

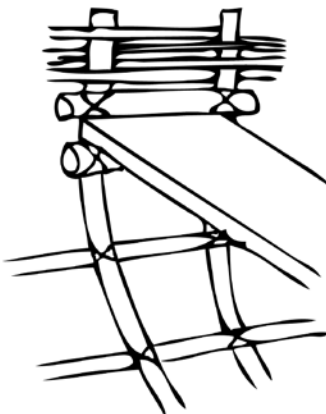

Seat Detail

The seat should be fixed against the frame of the craft and secured by a top and bottom brace.



The coracle is paddled by leaning over the edge of the craft as shown and using a drawing stroke in a 'S' movement. This may feel strange at first but is the best method of propelling the craft.

Ensure everyone who uses the craft can swim and is wearing a lifejacket.

Venturer Fun and Games

Onion Jousting

Mark off a boundary that's about 2 metres in diameter. Find two participants. Give each person two spoons (soup spoons or large serving spoons) and an onion that will rest comfortably in one of the spoons (no onions so large that they topple out at the slightest movement)-Indicate to players that they must place onion in one spoon then hold that spoon by the handle only-, they may not touch the onion. They should hold the empty spoon in the other hand. Once the players are ready, let the joust begin. Players attempt to knock their opponents onion to the ground using the empty spoon only while protecting their own onion from falling

Rules

No excessive bodily contact is allowed no pushing, shoving, tackling, tickling or foot stomping. The well-played joust resembles a dance as players twist, bob, weave, bend, gyrate and contort themselves to avoid the thud of their onion falling to the turf. It's beautiful in an odd way, and quite a bit of fun as well. To up the ante a wee bit, substitute eggs for the onions

Paper drop

An exercise to improve eye to hand contact and reaction time.

You will need a number of paper or light card strips 15 cm by 6 cms. The game is challenge based using two players. One



player holds the strip of paper between his/her thumb and forefinger in a pinching motion. The other positions his/her hand in an open pinch position about a 20mm below the strip of paper as shown. The paper is now dropped by the challenger and his/her opponent tries to catch it as it drops through their fingers (just pinching - no dropping or scooping motions with the hand allowed). Not many individuals have the reaction time to make that kind of rapid psychomotor movement. Before you start the drop and-grab sequence, mark the length of paper (top to bottom) in 2 cm gradations so you can estimate and measure the reaction time of different people. Start with the bottom of the paper just between the fingers. Don't allow any anticipatory sounds or movements. For example, don't say, '...ready, set, GO.' Have lots of measured sheets available so that players can operate in pairs.

Back Stabbers

You will need about 50 clothes pegs. If the pegs come in different colors, that's a bonus for eventual team designation. You can spray paint the wood pins to achieve the team colors needed.

Hand out 4 pegs of any color to each participant. Indicate that players are to try and get rid of their pegs by clipping them onto the clothing of any other player, who will also be trying to do the same. As soon as a player legally gets rid of all four clips, he jumps up and down, simultaneously shouting that he has accomplished this. and if anyone is listening, that person is eventually recognized as the winner. Emphasis is obviously on the action rather than the outcome. Clipping of pegs is only allowed above the waist. As such, all the clippers begin to look like matadors attempting to place banderillos in the bull

Rules

Clipping or entangling hair is a no-no. If a clip stays on for 5 seconds, it is considered a legal clip.

If a clip spontaneously falls off before 4.99 seconds have elapsed, it must be picked up by the clipper for another try. Clippers may not rub their clipped body against another person, or the wall, or whatever in order to dislodge a legal clip. Clothing cannot be grabbed to slow down a running player, or to facilitate a clip.

Boundaries area needs to be established.

Stepping Stones

One prop per person and two ropes or another suitable method for identifying the Take-Off (Point A) and the Safe Zone (Point B).

Props can be:

Carpet tiles - 12' squares work well or, odd-shaped pieces big enough for 2 - 4 - peoples feet to squish onto 18' lengths of 4'x 4" timber
Extras: One suitable object to be carried along by the group

Set-Up

The basic set-up here is the old Point A to Point B without touching the ground in between-routine. People are assembled at Point A. given one prop less than their number; i.e., nine people get eight props and told to arrive safely with the entire group at Point B before time runs out. If this sounds too much like the same old thing, here's the fun way.

Pencil fun

Try and draw the shapes displayed is one action - without taking the pencil from the paper. You can not backtrack over previously drawn lines

Life support

People are on Planet Venturos a marvelous world of beauty, peace and

intellect. The people there want to spread their lifeform throughout the universe so they are embarking on a space voyage to another world. To leave the planet they will need special life-support vehicles to carry them safely through space and shield their genetic treasure. Their life-support vehicles are the props. Any life-support system can support as many people as can stand on it.

Rules

Anyone touching the ground in space; i.e., between the boundaries, must return to the home planet for decontamination and spiritual healing. Rescuing these fertile travellers is recommended, since all people are expected to arrive safely at the new planet. For a life support vehicle/system to function, someone must be touching it at all times when it is in space to maintain the 98.6° temperature necessary to maintain DNA viability. If a life-support is untouched for even an instant, it ceases to function and it is immediately removed from the activity.

Example: A person tosses the support onto the ground, and then steps onto it Because it left that person's grasp when it was tossed, it is lost forever. A correct use would be to place it on the

ground and step onto it while having constant touch with the prop by hand. Be extremely watchful for untouched life supports. People try to hide the fact that they make a mistake. Don't let a untouched prop remain in use

Setting boundaries: Generally, it makes sense to set the boundaries far enough apart so that the group will need to recycle some of their props in order to cross the gap

Foot-o-war

A length of lashing rope has a loop tied into, each end using a bowline, being large, enough to slip on (and off) a foot and a rag is tied around the centre. 3



lines are drawn on floor or ground as for tug-o-war. Participants are called to the play area, a pair at a time, and must sit opposite each other. They each slip the rope onto one, of their feet, and the rag is placed over the middle line.

On the word 'Go', they must attempt to pull their opponent so that the rag passes the line nearest to them. If the loop-slips off a Venture Scouts's foot, he/she has lost.

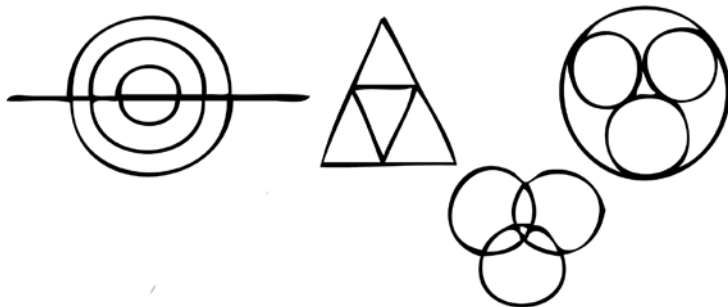

Mountain Leadership

BOS (The Irish Mountain Training Board) is the body designated by the Mountaineering Council of Ireland (MCI) in association with educational and youth groups to supervise mountaineering training in the Republic of Ireland. The Board does not arrange courses, but approves courses based on its standards and makes the appropriate awards to those who have completed the requirements and passed the assessments.

The Mountain Skills Scheme

The Mountain Skills Scheme aims to help hill walkers to look after themselves in the Irish Mountains. The courses provide training in the basic skills required to carry out hill walking competently, safely and enjoyably. Aspects of navigation, equipment, safety and mountain hazards are covered. The training is particularly suitable for:

1. Members of mountaineering clubs who wish to obtain formal instruction in basic skills to supplement experience gained in club activity;
2. Members of educational, voluntary and youth organisations being introduced to Hill Walking as part of a broader training in Adventure Sports.
3. Prospective Mountain Leadership Candidates.
4. Anyone who wants to learn basic mountaineering skills for personal interest.

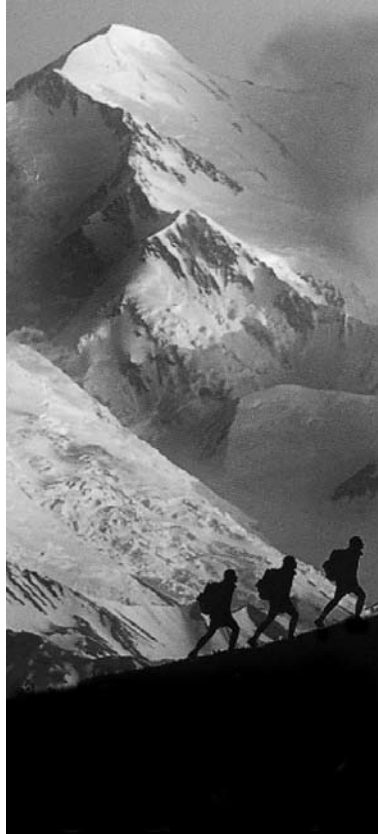

Completion of a Mountain Skills Course does not constitute a qualification to lead others in the hills.

Mountain Skills Programme

The courses are run by approved centres and organisations and follows the syllabus laid down by BOS (The Irish Mountain Training Board). The minimum duration for the course is 4 days and 2 evenings but it can take other formats. At least 5 hours of each day is spent on practical instruction in outdoor skills on the hills and

mountains and a reasonable standard of fitness is necessary if candidates are to benefit from these sessions. Participants are recommended to obtain further hill walking experience in the company of small groups in which they have an input into group decisions.

The Mountain Leadership Scheme

The Mountain Leadership Scheme provides training for any hill walker who takes responsibility for others in the hills. It is designed to help hill walkers to lead groups safely in the conditions normally encountered in the Irish hills and is most appropriate to those who are:

1. teachers or youth leaders taking groups into the hills, whether or not mountaineering is their primary aim;
2. leading groups on basic courses in a Centre, Camp or Mountain Tour Organisation;
3. training inexperienced people in a Mountaineering Club. it does not provide training in rock climbing or in winter mountaineering except as is necessary to give a leader confidence in dealing with rocky terrain or coping with an emergency situation.

Entry and Participation

Candidates who hold a current First Aid Certificate and have passed the Mountain Skills Test within the previous 3 years may register with the Board which administers the Scheme. They are then issued with a Log Book, and may commence training under the scheme. The fee and registration lasts for two years after which it must be renewed if the candidate has not gained the award within that time.

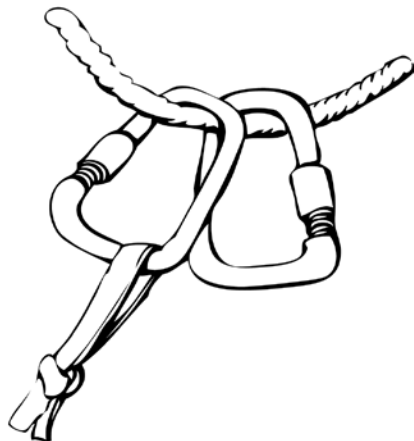

Scheme Requirements

These can normally be completed in twelve to eighteen months but longer may be taken if necessary. The training falls naturally into four parts:

- (a) formal training in Mountain Leadership and First Aid;
- (b) the acquisition of personal skills and experience;
- (c) the acquisition of leadership and instructional skills;
- (d) the acquisition of background knowledge.

The formal instruction and assessment can only be taken on courses approved by BOS. You should contact these centres directly for details of course dates, costs etc.

Training Courses

Candidates must attend a Mountain Leadership Training course of five days. The course, which may be spread over 2 weekends, provides an introduction to

the training and functions of a mountain leader. The Syllabus expands on the basic skills of hillcraft. It also includes aspects of leadership, conservation and access, movement and protection on steep ground, river crossing techniques, and incident and accident procedure. The final 3 days of training are held in rugged mountain terrain and include a high mountain camp.

Mountain Experience

It must be stressed that the experience gained by the candidate is at least as important as the formal instruction received when it comes to assessment. A total commitment of at least 40 days, (including at least 20 quality hill days of personal mountaineering experience) would normally be required to cover the experience and leadership requirements and to practice and gain proficiency in the assessed skills.

Further information on these course and others can be obtained from the Mountaineering Council of Ireland

Web site - <http://www.mountaineering.ie>



Canoeing and Canoe Leadership

Canoeing falls into two distinct types - the Kayak - enclosed canoe and the Canadian Canoe - open canoe. Both types are popular in Ireland and offer different experiences on the water.

The Canadian Canoe

The Canadian Canoe or Open Canadian is immediately distinguishable from a kayak because it is paddled using a single bladed paddle. The canoe originated with the native tribes of North America and was traditionally made from a timber frame covered in one of a variety of barks, usually birch. Nowadays, most canoes are made from plastic, fibreglass, or aluminium. The original designs which were used to travel across the large expansive lakes of Canada were open on top for transporting people and goods.

Canadian canoeing is particularly suited to exploring the inland waterways of our country. Ireland offers an attractive network of inland waterways for canoeing - providing endless possibilities for exploring, fishing, and multi-day expeditions. One attraction of this form of canoeing is that it can be enjoyed by the whole family. Whilst the majority of those involved in canadian canoeing favour leisurely trips on slow moving rivers such as the Shannon or Barrow, others have begun to use canadian canoes in marathon races. Due to innovations in

materials and design, canoes are now seen increasingly on rivers with small rapids and fast moving water.

Kayaking

Kayaks are enclosed canoes and although they can be used on quite waterways it is more suited to rough water and as a result is suited to wild water and slalom competitions and races. The Slalom canoeist races alone against the clock. In this discipline, the challenge is to pass through approximately twenty five gates suspended above the water, avoiding a touch with any part of the boat, paddle, or body. The competitor must pass through the gates in the correct order and direction.

An exhilarating canoeing discipline in which participants race down white water rivers against the clock. Races are conducted on a time trail basis with each competitor starting at one minute

intervals and racing over rapids of varying difficulties. The successful racer chooses and negotiates a route which is as obstacle free as possible and at the same time utilises the fast current to the best advantage.

The Irish Canoe Union run a series of course which will enable canoeists to gain instructor or canoe leadership qualifications. These course are run by approved centres and by the Irish Canoe Union. If your Venture Unit wish to persue canoeing as a long term activity, such as through a sea scout group then leaders must hold a Canoe Leadership qualification. If however, your Venture Unit want to dabble in canoeing at diffenret times during the year then we recommend doing activity sessions at an approved adventure centre or with a canoe club or Sea Scout Group. Below we outline the basic structure of the Canoe Leadership Courses. Contact the Irish canoe Union for current course calender.



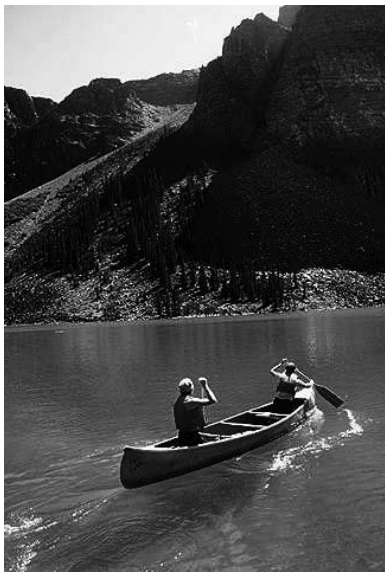

Level 1 Kayak Instructor

Qualification

The Level 1 Kayak Instructor Qualification aims to enable candidates to become qualified to instruct introductory, basic, and intermediate proficiency level kayaking skills on water of no higher than Grade I difficulty including Very Sheltered Waters and/or Sheltered Tidal Areas. A Level 1 Kayak Instructor is specifically not qualified to lead groups and is restricted to static instructional sessions only.

Training Course Outline

The Level 1 Kayak Instructor Qualification requires that a candidate attend a two day training course (or a programme of similar duration) and a one day assessment.

Applying to attend a Level 1 Kayak Instructor Training Course.

Before applying to attend a Level 1 Kayak Instructor Training Course, a candidate

Must have registered with the Irish Canoe Union as a Level 1 Kayak Instructor Trainee. Be of a proficiency level equivalent to the Level 3 Kayak Proficiency Award. Be at least 16 years of age at the time of application.

Have unrestricted access to a fully equipped kayak, personal equipment, and additional equipment as listed for a Level 1 Kayak Instructor Assessment.

Progress

This is an outline of the basic instructor level once completed you can then progress to other levels of proficiency. The progression across the more advance levels will require a lot of time and experience. Generally speaking those who progress to these levels are serious participants in the sport of canoeing.

Area Definitions for Canoeing on Rivers and Lakes

Very Sheltered Water

Canals

Canals with bank side access and egress and which have a minimum of commercial traffic.

Lakes

Small lakes which do not have difficult landing areas and which are not large enough for problems to occur if there is a sudden change in conditions.

Rivers

Specified sites on slow moving rivers.

Sheltered Water

Rivers

Flat slow moving rivers without weirs or rapids.

Lakes

Discretion and common sense must apply when considering the use of lakes. This definition includes a perimeter of no more than 250 metres from shore on a large lake. To paddle in offshore breezes on large lakes requires the same degree of caution as for the sea.



Town Planners

One way of developing useful group qualities such as team building, negotiation and compromise skills is through exercises such as this. The purpose of this exercise is to put the group through a process whereby:-

Each member must examine a problem and form an opinion.

The group is then asked to reach a consensus solution to the problem - thus conflicting opinions must be challenged and questioned.

The group is put in an artificially induced situation where it must handle conflict and disagreement between members while keeping a target in mind.

Town planners

You are a group of town planners employed by a local county council to design a new town. In designing the town you are limited to the restrictions imposed by the County Council.

You must design the ideal Newtown which will agree with our philosophy of equality of opportunity and freedom to all regardless of wealth, religion, class or politics.

On your site you must build the following:-



Housing Types

- 2 No. Blocks of luxury flats (20 units)
- 1 No. Council Housing Estate (200 families)
- 1 No. Private Owned Housing Estate (500 families)
- 1 No. Itinerant Site (10 families)
- 2 No. Blocks Council Flats{ 50 Families)
- 1 No. Luxury Bungalow Estate(50 Units)
- 1 No. Block of Old Folks Flats{ 30 units)

Community Resources (Choose only 9)

- R.C. Church
- Church of Ireland Church
- Post Office
- Shopping Centre
- Fish and Chip shop
- Hairdresser
- Health Clinic
- Doctors Surgery
- Rape Crisis Centre
- Social Worker Office
- Pub
- Family Butcher
- Fire station
- Garda Station

Schools { Choose only 4 }

- Vocational School
- Secondary school (Boys)
- Secondary school { Girls}
- Community Comprehensive School (Co-ed)
- Primary school (Co-ed)
- Boys Primary School
- Girls Primary school
- Montessori School
- Play school
- All Irish school (Primary & Secondary)

Other services (Choose 3)

- G.A.A. Club (with bar)
- Rugby Club Youth Club
- Scout Hall
- Community Centre (also used as Drop - in Centre)
- Golf Club

Financial services {Choose 2 }

- Credit Union Building Society Bank
- Commercial bank Pawn Broker

Compulsory

- Chemical factory
- Dump
- Cemetery

Detailed plans can be drawn up based on the map opposite.

Map of proposed area to be used for Newtown development

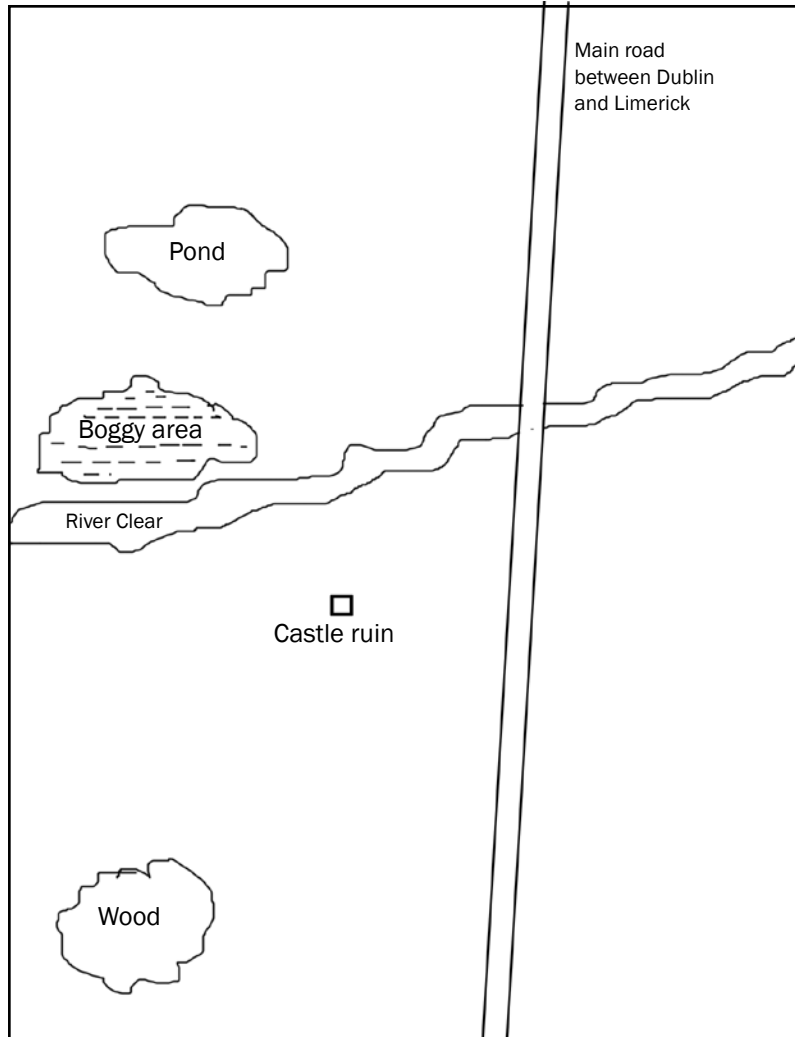

Scale
1 Km

Homemade stoves

All of these stove are experimental, cheap alternatives to manufactured stoves. You should always test them in the out of doors. Never use them inside a tent.

Illustrated here are a number of home made stoves you could try to make and use. All are made from scrap materials. When you have made them, test them in an outdoor setting and calibrate their efficiency against a manufactured stove. The test should be simple - how long does it take to boil a billy of water. You will be surprised at the results. These stoves are very efficient. There are many more examples to try, search the 'net' to discover other examples.

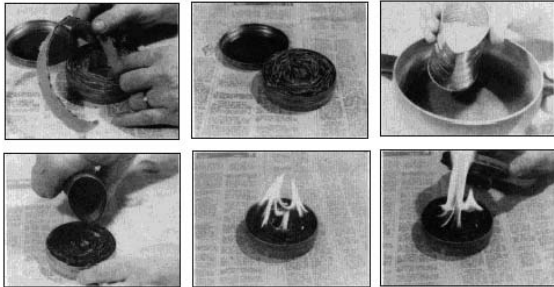

The cardboard/wax stove is easy to construct. Tear up strips of cardboard so that they fit inside a travel sweet tin. Melt some old candle stubs to create a wax and pour into the tin so that the cardboard is set in the wax. using a scissors cut the tops of the cardboard coil slightly then set alight to char the cardboard. Your burner is now ready for use.



There are two parts to this Meths stove - the burner and the stove housing. The stove housing is created from an empty wide topped tin - like a salmon or fruit tin - using a tin can punch. The burner is created using an empty drinks tin, some fibreglass and a piece of mesh.



When testing and using this burner half - fill only with methylated spirit.

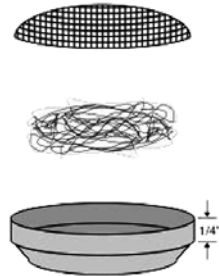
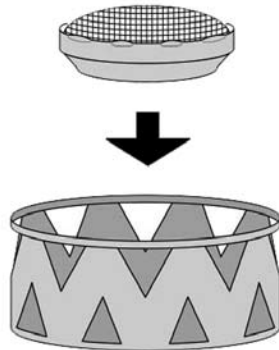

Cut base of drinks tin as shown.

Place some fibreglass in base - pack firmly but not too tight.

Place mesh of fibreglass and press in edges of tin to make a unit.

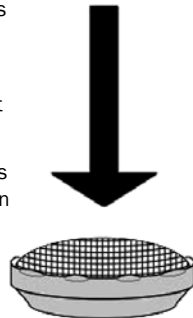



Meths stove mark II

This stove uses a burner created using empty drinks tins, some 'Perlite' from a garden centre and a coat hanger.

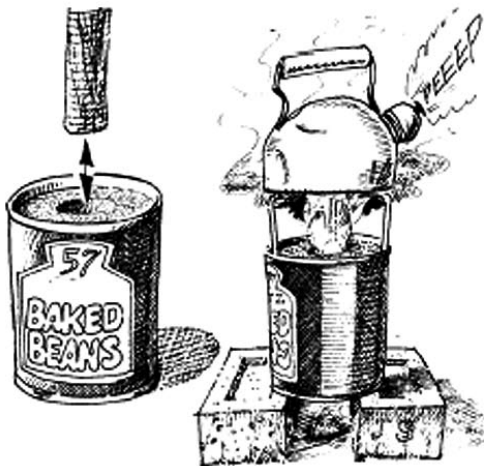

Sawdust Stove

This is a fun little stove to use. Get a bean tin and place a number of holes in the middle of the base of the tin. Now place a stick in the middle of the tin and pack around the stick with sawdust. Gently remove the stick so as to create a tunnel. Place a few metal tent pegs around the sides of the tin and away you go. To light - place on a few rocks so that air can enter from the bottom of the tin, then light a piece of paper and place in the tunnel and she will burn away.



Start by creating the burner. You will need two drink tins cut as shown with the side walls slightly shorter on one of the bases. The bases need to fit together to create a chamber. A good scissors is ideal for cutting the tin.



Take the base with the smallest wall and using a 'darning' needle punch 4-6 holes in the middle of the base and a large number of holes around the rim. Try to space the rim holes as evenly as possible.

Buy a bag of 'Perlite' in a local garden centre - is is used in compost mix to open up the soil structure - it is like a white absorbant grit.

Fill the larger base with 'Perlite' and place the cover on top. Crimple the edges to create a solid burner.

When testing and using the burner only half - fill the burner with methylyated spirit. Light the burner in the middle of the base first. it will spread to other holes once it heats up.

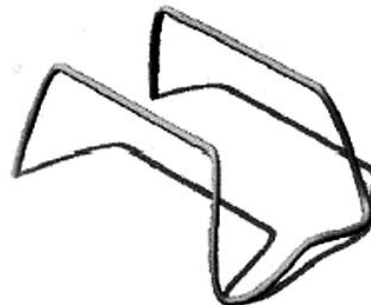

A pot stand is easy to create using an old coathanger or strong fence wire.

Power Kites

For centuries the only type of kite you could get was a single string kite, what you would recognize today as a diamond or box kite, that simply went up and stayed there. If your memories of kite flying are tangled lines, kites in trees and running backwards trying hopelessly to get your kite into the air, then you are in for a big surprise. Kite flying has come a long way over the last 20 years and many are now high tech, high performance machines.

The Beginning of an Adventure

It is said that the kite was the second toy ever invented by humankind. So you can argue that the enjoyment of kites is now deeply embedded in the human psyche. You can also argue that, until recently, kites had kept the some basic design and flying qualities they were first made with. In spite of this few children or adults could resist the magic feel of the tugging line or the idea that they could control this flying object.

Mankind has been obsessed with the idea of flying for thousands of years. The kite represented one way he could physically attach himself to the concept of flying. It was inevitable that one day kites would drag themselves into the modern age and that's what has happened to stunt/sport kites particularly. The fun and excitement that comes from a stunt kite is the same as you can get from bikes, skateboards, roller blades and snowboards. Once you've got the kite you can let rip with your imagination and find enjoyment in your toy far beyond what may, at first, appear to be possible.



Power kiting uses a large kite or high winds to produce a load big enough to move the flyer. Most of the variants of power kiting— especially the popular ones— are some type of sailing. All of the sailing forms use a large kite or a stack of kites as the power source for some vehicle however large or small. The kite is always steerable so that the flier can position it in the sky similar to the way a sailor trims a sail. The pilot can sail the craft upwind downwind or across the wind just like a conventional sail boat. However the kite allows techniques and speed not possible in any conventional sail boat.

Kite dragging and sand skiing use the kite to move the flyer downwind. Kite jumping uses the kite to lift the flyer off the ground and cushion the return to the ground. Man lifting suspends the flyer off the ground.

Activities

The following are all examples of Power kiting activities where kites are used as the traction system:

- Stacking
- Jumping
- Scudding
- Body Surfing
- Bugying
- Kite Surfing

Jumping

Jumping can be done using either two line or four line kites. Use the power of the kite(s) to lift you off the ground both upwards and forwards. This is best done on the beach as the sand provides you with a soft landing.

Scudding

Scudding is the art of skidding along the ground on your feet. You can use either a two or four line kite for this but a four line kite will provide you with smoother and more constant power. The longer you can keep the kite in the Power zone, the further you will skid. The stronger the wind, the faster you will travel.

Body Surfing

Stand in the sea with the water around waist height with the kite flying directly above your head. Bring the kite down in to the Power zone and lean forward at the same time. Keep the kite flying in the Power zone and you will be pulled forward through the water. You may find that at times you are pulled right out of the water by the power of the kite, considering the strength of the wind.

Both Body Surfing and Scudding are excellent ways to discover the kite power before you move on to activities such as buggying

Kite Buggying

Kite buggying is probably the most popular form of power kiting. It is easy to learn, safe, fun, and there is good gear available commercially. When buggying, the buggy pilot sits in a small, light vehicle while flying a kite that pulls the pilot and buggy. The seat is usually low to the ground and the wheels are no more than an arm's reach away. The pilot steers the buggy with pegs attached to the front forks. For power the pilot flies a steerable kite. The kite pulls the pilot and buggy much as a sail pulls a sailboat. The buggy can go upwind, downwind or across the wind at



speeds from 5 mph (8 kph) to 50 mph (80 kph) or higher.

Kite buggies are quite maneuverable and easily controlled. The pilot can steer a course between objects, accelerate or decelerate at will and easily stop the buggy. The buggy can safely approach people and even turn circles around them. Similarly, the kite is easily steered around trees, sand dunes and other kites. Aside from the obvious need for a kite buggy and a kite, kite buggying requires only a large, open space and a some wind. The most popular surfaces are beaches as they provide some of the best and broadest rolling surfaces, but a mown field can be quite fun and is a common choice



Puzzles and games

for a 'crystal maze' activity night

Presented in the next few pages are a number of puzzles than can be used to form the basis of a mind challenge programme or 'Crystal Maze' Activity night. There are many others that can be used and are available in puzzle books and on the web. The group is best organised into small teams of 2-3 people with each challenge run to a time limit.

Challenge 1

Place all the words in the crossword grid so that every word across and down is a proper word.

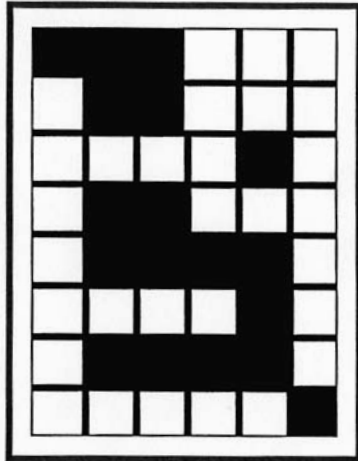

H
O
P

O P E N

S
O

T
E
A

E V E R

O
N

B
A
L
L

A
N

M E N

G A S

Challenge 2

Using each number, 1 through 10, place them in the circles so that no consecutive numbers are connected by a line.

For example, 4 cannot be connected by a line (in any direction) to 3 or 5

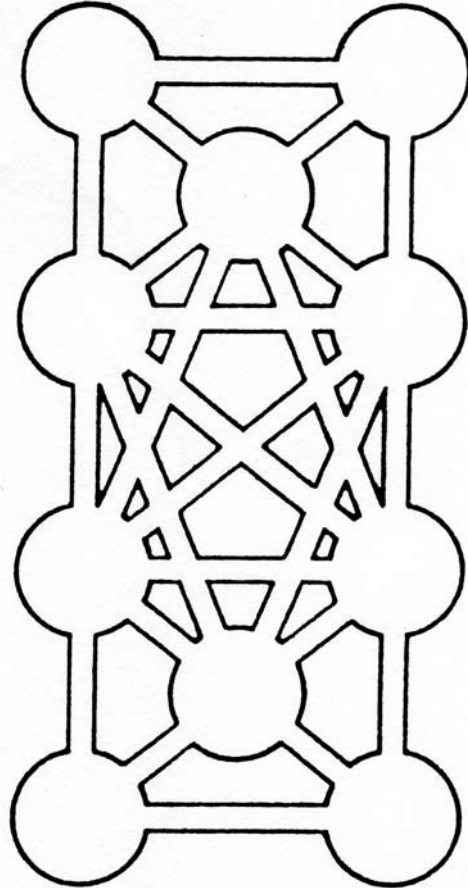

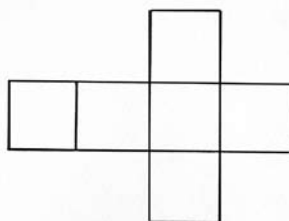

Dice Plan

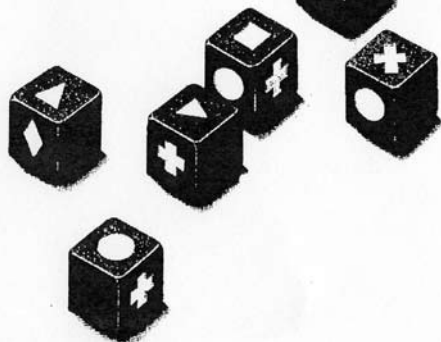
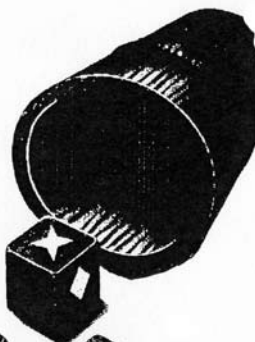

Challenge 3

The six dice shown here represent different views of a single dice. Some symbols on the dice are missing however - and one of the views is deliberately misleading; it is from a completely different dice.

Can you work out the symbols of each side of the dice. Draw up a dice plan as shown and place your answers on it.

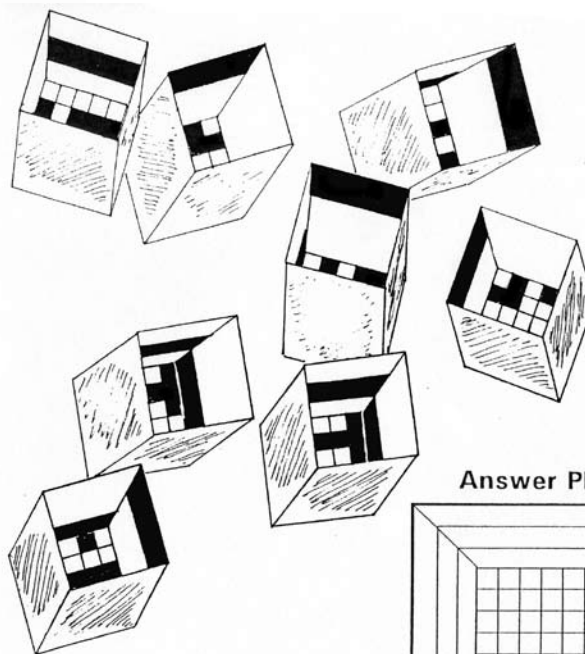

Answer Plan

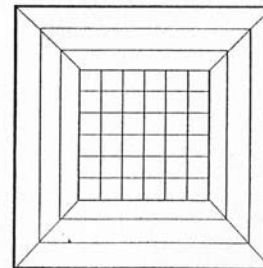

Challenge 4

Imagine you are looking into a hollow cube. At the bottom of the cube you see a pattern of 6 X 6 squares. The complete pattern cannot be seen at any time however there is enough information in what you can see to deduce the pattern. The decoration on the side wall of the cube may be helpful. Create a pattern sheet as shown and map out your answer on it.

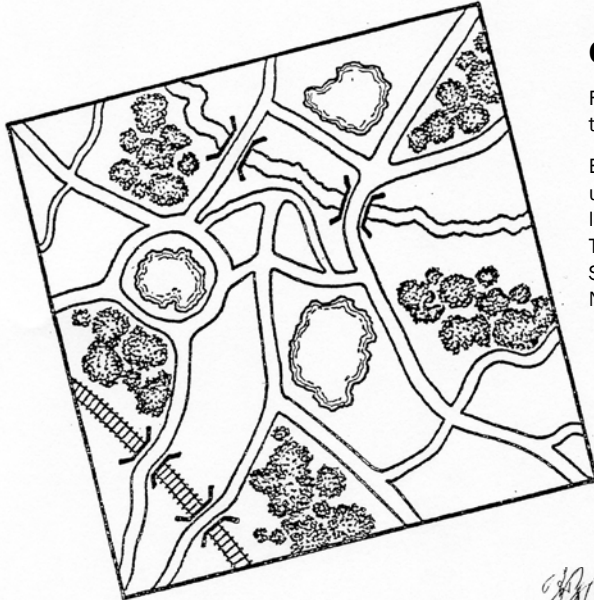

Challenge 5

Find the treasure - thread carefully as no direction is provided on the map.

Begin at the northwest corner. Go South east along the road until you reach a bridge. Cross over and take the first road which leads away from the woods. Follow this road until you come to a T - junction by the pond, where you must turn right, then take the South west road. At the next point where four roads lead to neither North, South, East nor West, the treasure lies buried.

Challenge 6

Five missionaries are on one bank of a river and five cannibals are on the other. The only method of crossing is by a canoe and only one missionary and cannibal can paddle. The boat can hold three men. The missionaries do not trust the cannibals, and are unwilling to be outnumbered either in the boat or on either shore for the time it takes the boat to cross. What is more, the cannibals feel exactly the same way about the missionaries. Can you devise a way in which each group can cross the river.



The Egg Challenge

This exercise is designed to develop teamwork, inventiveness, and construction skills as well as developing the mental skills of the group.

Each team of Venture Scouts are set a constructive task, whereby they have to design and build a gadget from miscellaneous bits and pieces of no real value. The teams must then complete the objective against each other and the clock.

Each team will need some equipment

1 No. Elastic Band (power source), Cling film, newspaper, sellotape, pipe cleaners, milk cartons, paperclips, odds and ends

Projects

Move an egg from one position to another 10 metres away. Without breaking it, or touching the ground

Lift an egg 1 metre off the ground over a barrier and onto the other side, without breaking it.

Construct an egg timer, to tell exactly 2 minutes, every time.

Construct a devise that will package an egg, this devise must be capable of travelling a distance of at least 3 metres (off the end of a plank) and survive a freefall from the top of the hall or den - a decent fall.

Time limit

Write out the projects and seal in an envelope. Give each team at least 1 hour to

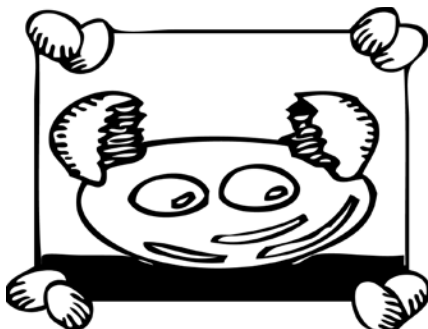

make the craft or devise. Allow half an hour for testing.

Contest Rules

Only one egg will be given for testing purposes, and one egg for final test.

Eggs may not be taped or cast in a solid

The craft / devise must be easily opened to display, insert and remove the egg.

A streamer maybe attached to the freefall craft but it can be no longer than 3 metres

In the construction of the craft / devise you may not use padding of any type to protect the egg. You can however employ shock absorbers but they can only be activated on impact - something like an air bag in a car or crumple panels in cars that collapse on impact.

The craft / devise must be self propelled - once it is set up to go it must travel by its self.

Rules can be changed at short notice to circumvent the 'benders -of- rules' and (heaven forbid) 'cheaters'

Hints

for experiment and practice

In designing your craft/devise, first consider the basics you have to work with - a one litre milk carton, an egg, some sort of shock absorber, bits and pieces and perhaps a streamer. As you experiment, consider what you can change, here are a few suggestions: -

Change the shape of the carton, its weight, surface. Add nose cones, bumpers, cushioners.

Change the egg position

Change the shock absorber, size,shape, weight, material. Try elasticity, crushability, padding, and cradling.

Change the streamer, size, shape, weight, material.

Changes to the fins and flaps for guidance.

Okay you say but you can try out a lot of eggs trying out different designs and modifications. You don't need to waste fresh eggs. You could use hard boiled eggs and eat them later.

Marking the contest

Suggested marking system

Design	25
Teamwork	25
Result	40 (Does it work)
Effort	10

The Mess

It is an excellent idea to cover the floor of your test area with a sheet of plastic taped to the floor. Each team is responsible for cleaning up their mess (the best part of it at least). When the challenge is over, the plastic can be rolled up and placed in the bin.

Challenge Games

Many science game activities can be utilised into an effective challenge activity for your venture Unit. The challenges are designed as team challenges some with time limits. Others can be stand alone programme inserts or part of the overall evening challenge.

Preparation

In order for this activity to be successful it will be necessary to compile and have available the relevant materials in quantity for the teams to use. In compiling this equipment you will have to imagine in a number of cases what the teams may come up with as a solution to the problem and anticipate the equipment needed.

The Challenges

Make a beam with a span as wide as possible which, when supported (but Not Fixed) at each end, will support a weight at its mid - point.

Materials
One sheet of thin card, one roll of sticky tape, scissors, a 250 gram, weight.

Support a drinking glass on a bridge made from a five euro note.

Materials
Three drinking glasses of the same size, a crisp new five euro note

Use one tabloid newspaper to build a bridge that will span one metre and hold the largest load possible. You have 25 minutes.

Materials
Newspaper, paper clips, staples, glue, scissors, objects of varying weights.

In 20 minutes, build the highest possible tower using all the cards.

Materials
A full pack of playing cards.

Construct a structure or mechanism that will carry a marble over the greatest horizontal distance before it comes to rest.

Materials
Two sheets of card, 100 paper clips, 10 drinking straws. 40 pins, one marble.

Build a free standing structure that will support a 0X0 cube as far out as possible from the edge of a table without touching the floor.

Materials
50 drinking straws, 40 pins, one 0X0 cube

Build a device within an area 25cm X 25cms that will allow your entire team to stand 60cms off the floor at the same time.

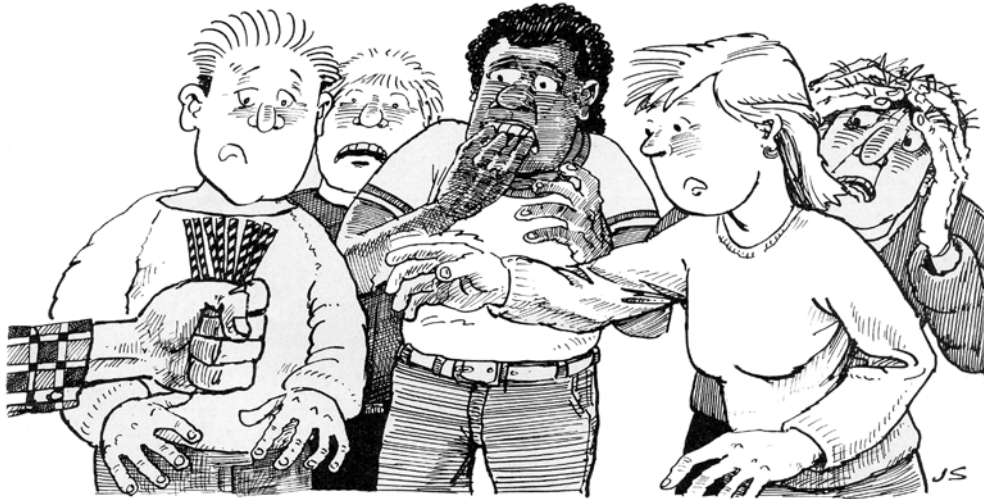

Materials
six spars, rope

Build a raft able to hold the largest mass without sinking. You may use as many sheets of paper as you like, but may not cut them to make them smaller. After 10 minutes construction time, you will put your rafts to the test by floating them. You may not test designs in water before the final float test.

Materials
A stack of sheets of paper all the same size, a supply of marbles or pennies and a basin of water for the testing

Invent a device to : - weigh a wild bird without causing it any harm, and another measure the growth of a plant over a period of one week.

Invent a musical instrument - percussion, stringed, or wind. Play a little tune on it. Put together a band.

Material
Bottles, tins, water, elastic bands , dried peas.

In 20 minutes, build a free standing tower that will hold a tennis ball one metre above the floor

Material
tape, drinking straws, scissors, tennis ball, elastic bands, paper clips.

Design and construct a vertical 'Adventure Playground' for a marble. The aim is to produce a system of interesting devices or events that will delay the marble's descent from one metre without the application of external power. The winning device will be

the one that delays the marble's descent the longest and includes the greatest number of devices.

Material
A base board 30cm X 1 mt, craft sticks, pieces of cardboard, pins, odds and ends, a marble.

Use a warming candle to provide power to a mechanical device that will move an object a distance of one metre.

Make a paper helicopter that will take the longest time to fall to the ground from a height of 3 metres.

Material
Sheets of paper, tape, scissors.



Put a piece of paper underwater without getting it wet.

Material
Sheets of paper, a drinking glass, a pail of water.

Construct a device that will propel itself along the floor.

Material
Craft sticks, twigs, tape, glue, pins, elastic band.

From any household items, build a gadget with as many moving parts as possible that will successfully perform as an alarm clock.

Material
A stockpile of candles, elastic bands, tin cans, thread spools, and other odds and ends.

With the fewest drinking straws possible, build a framework that will support a cup full of water at least 5 cms off the ground. You have 25 minutes. You can test your frame as you go, but only on half a cup of water.

Material
Drinking straws, pins, elastic bands, tape, paper clips, scissors, plastic cup with drinking straw through the top (just below the rim, punch hole on opposite sides of the cup and slip in a drinking straw).

Scout Engineering

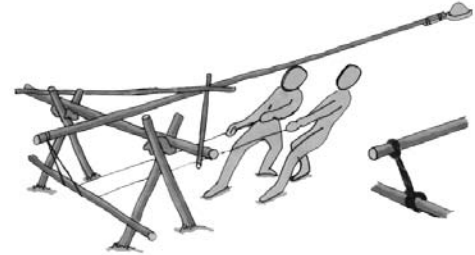
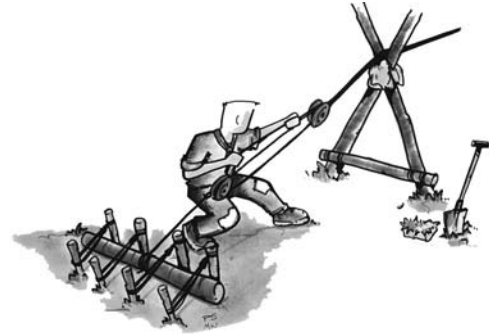

Scout engineering or pioneering is a great activity for Venture Scouts. As you are a little bit older and wiser the construction of large and small scale projects are easily achieved with a bit of effort.

Projects such as suspension bridges, towers, tent platforms are great for creating spectacles at a local campsite or County event.

You will of course have to revisit your knot and lashing tying skills. These are contained in the Scouting Trail Handbook along with many other ideas than those illustrated here. If you are new to the idea of scout engineering then start with a few easy projects and build up to the major undertakings such as a suspension bridge.

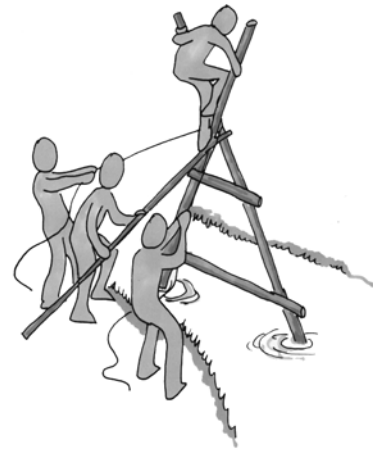
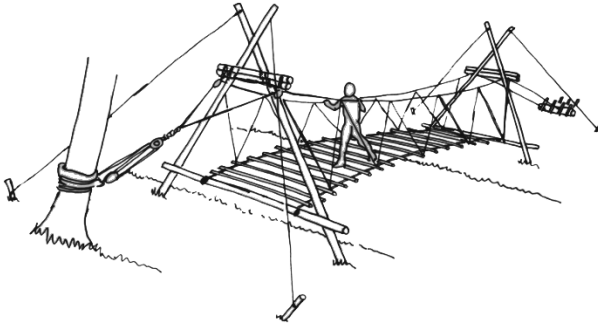

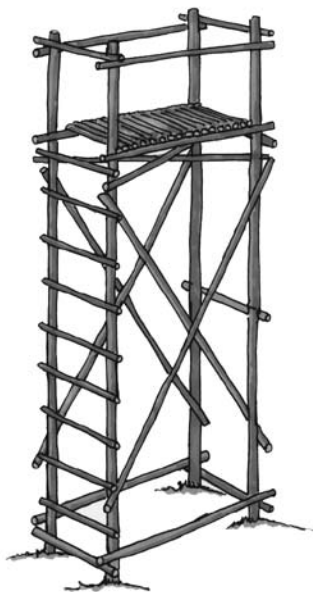

The best location for building a project is your local campsite. They will usually have poles and ropes available. The campsites will also have ideal locations for building bridges.

A tent platform with built in kitchen and dining facilities is a fun project to build. It requires a knowledge of all the basic lashings and knots. When it is built it is likely to attract a lot of attention from Scouts and Cubs who will want to climb up and see what it is like.

Your Unit could also consider constructing permanent features on your local campsite such as gateways, towers and bridges. Normally, a pioneering structure will be built for the duration of a camp or event and then taken down but a permanent structure - that's making your mark! and displaying your skills to all.

Could you become the County pioneering experts?

Many Scout sections and Patrols lack the skill and knowledge to undertake big projects and this is where you can step in and become experts. Refine your skills while building your own projects and then offer to assist and train others in the County.

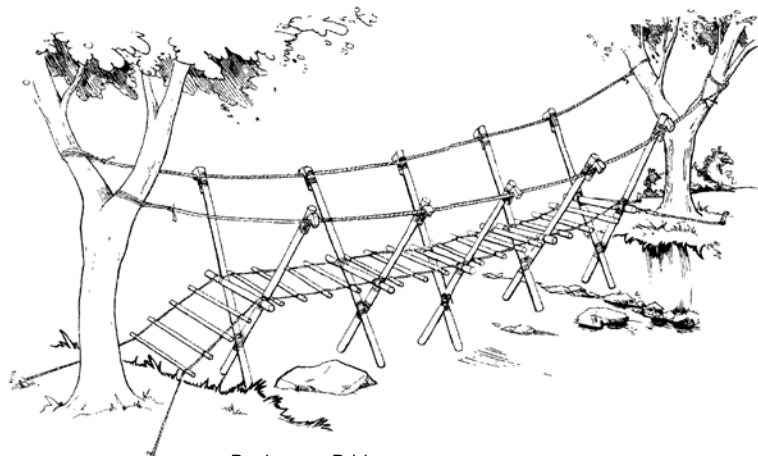

Bushmans Bridge



Pioneering Projects

There are many different and well tried projects for you to try and when you become 'experts' you start designing your own. Each location presents its own set of possibilities and challenges so often the design you have on paper may have to be modified as your build.

Nearly all projects are built using the same basic shapes and structures - a 'A' frame, a 'Tripod' frame or a braced 'square' frame. If you study the illustrations of pioneering projects you will quickly spot the various elements that make up their construction.

Rope work and the use of pulleys are skills that need to be understood and practiced. The main difference between simple gadgets, gateways and large projects is the lifting and moving elements of the structure.

You will need to lift large frames into position, fix lines and ropeways to your structures and this is done by the use of pulleys and ropes. So, again practice makes perfect, start with basic lifting and move onto the methods and skills required to lift really heavy objects into position.

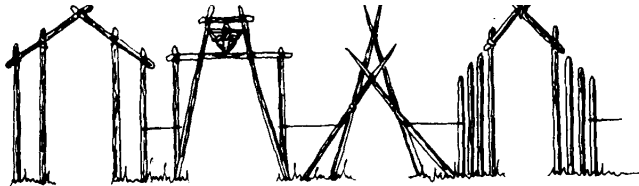

Don't mess around with large scale pioneering. Decide what you are going to do and set about doing it correctly. If you don't have the skills then ask an expert to give you a hand and learn by doing. Build

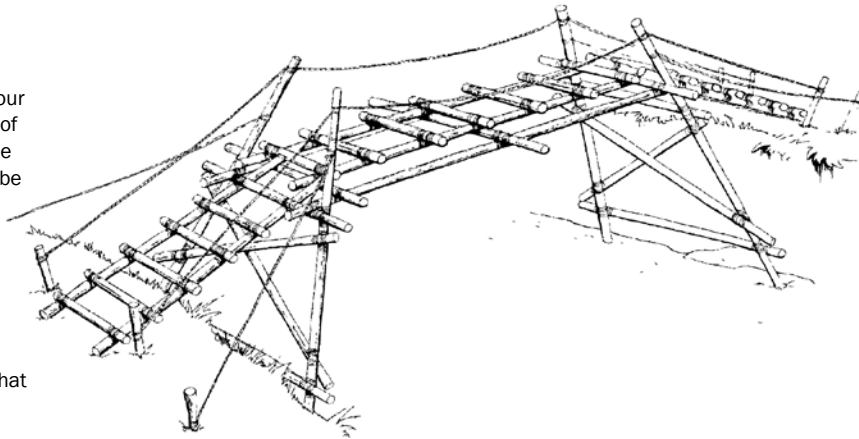

up or improve your skill with each project. The sense of achievement for all involved is great.

Safety

Safety is a consideration in all activities that we undertake but particularly so in pioneering. Watch out for the simple things - tripping over poles, rope burns, fingers being caught.

As well as the simple things there are of course the serious considerations

safe manner - definitely no messing!!!!

If you use your common sense and approach any project in a safety conscious way, with proper equipment and safety gear such as hard hats, boots and gloves then you will be successful and achieve a lot.

- making sure the ropes and pulleys are in good order and up to the job. Securing the project to the ground. The lifting process and the 'dropping down' process. All these have to be done in carefully planned and

Wide Games

“It was down to just the two of them—John from the Cobra Patrol and Billy from the Eagles, They knew that the fate of the universe was in their hands and that if they did not defuse the device it would be all over. John reviewed the clues that the Cobras had gathered. He remembered the phrase “Let the law be your guide” that all the people they had met that day had kept repeating. He looked down at the device, with its glowing lights and countdown clock running and pushed the button -just at that moment.... “

Are you looking to infuse excitement into troop activities and wide games your Venture Unit has been asked to design and organise?

Do you want to create an experience the scouts will talk about for years to come?

A wide game will answer all these questions with a resounding YES!

A wide game, for our purpose, is a series

of initiatives/challenges that are widely distributed in a geographical area that all related to a unified theme. Wide games share these characteristics:

- A central theme based on a movie, TV show, book, or video game
- A story, based on the theme, that the scouts act out
- A series of events that teach and test scout skills that revolve around the story
- A method to move the patrols from event to event
- A end game that rewards patrols that visit all the events
- A reward for completing the entire series of events

Themes

“On the day of the event the crew gathered about 1/2 hour before the scouts were to arrive, I looked over the most bizarrely dressed, strangely made up group of adults I had ever seen and gave out the last minute instructions.



As I watched them get in their cars to drive away, I put on my cape and Viking helmet and got the first set of clues ready,,,, “

Why use a theme?

For a wide game to be an effective teaching tool, it must immerse the young people in what they are learning. For example, before anyone in a team could begin to participate at a station, everyone in the team had to give the “password.” At each station, the password was a different knot each scout had to tie. Since the game was a race, all the scouts were really motivated to know all the knots by the end of the event.

The best way to keep the scouts’ interest (or disguise the fact that some actual learning might be going on) is to find a way to tie all the different skills together in a “real world” scenario. Of course, I am suggesting that the real world contain aliens, spies, dragons, crackpots and wierdos! This is where a theme comes in. A simple one or two line statement of what its all about will bring the crew/staff, the scouts, and the adventure all together.

Where do you get theme ideas?

Wide game ideas come from the interests of your Venturers. Television, movies, video games, and historical events are all great sources. If you listen to young people talk you will often hear some good references to what they are reading, watching, playing, etc.

If you’re stuck for ideas, go visit a games shop, movie theatre, toy or comic book shop or hobby shop.

Do's and Don'ts of Themes

Some basic concepts when you get ready to decide on your theme:

- Do use a theme that the scouts are familiar with (Mission Impossible).
- Don't use an obscure theme (The reign of Manillas the Elder).
- Do use a theme that is acceptable to all ages in the group.
- Do not stick with a theme if it becomes too difficult to work with.

Making your theme cover the entire wide game

There is no real trick or hidden technique to this. The key here is to take every event and activity, the navigation of the groups from activity to activity, and all communication about the activity and conform it to the particular theme. Here is a typical set of skills that will be used for a wide game:

Stations

"Tommy eyed the pool very carefully. He was sure that there was nothing in the water that would help him rescue the princess. Finally, he jumped in and began a Lost Bathers Drill like he learned at summer camp. A few minutes later he surfaced holding the clear Plexiglas sheet with a map etched in it! His smile stretched from ear to ear!"

Station/base

The individual activity station/base is the key to a successful wide game. This is where the scouts learn the skills and test their knowledge. It is best described as a location where a particular skill is taught and tested. The minimum requirements

for a station are simple... something to teach and some way to do it!

Navigation

"The Cobras were getting it... they discovered that a light year was the equivalent of 100 paces. The Patrol Leader started yelling " hurry up Vulcan is just 300 paces away! "

Connecting the Dots... Getting the groups from here to there

One of the major factors in the excitement of the game is moving the patrols from station to station. The successful wide game will not offer a linear approach to the stations, but rather a complex and challenging course. Compass, clues, landmarks, and any other method are all acceptable ways to move each patrol from station to station.

Ensure that your clues are permanent! If you use a landmark or clue that could be moved, knocked over, or otherwise changed before or during the event, notify the route staff. The route staff can check those clues periodically and fix them or report their absence.

Do the maths

Each location is a fixed location (usually) and is a fixed distance from every other station. It is necessary to plot a path from one station to the next FOR EACH PATROL. You should not have each patrol following the same station rotation. The game will not work if a patrol can simply follow the patrol in front of it and win. If you have only 2 patrols, a simple solution is for 1 patrol to go from station 1 to station 2 and so on while the other patrol goes from station 8 to station 7 etc. Sounds easy, but try it with 3 or 4 patrols! You want the total distance to be as equal as possible.

Decide how to direct the Patrols to each station

This is the fun part. Are they going to get clues? compass directions? bizarre bits of poetry describing landmarks? cryptograms? A creative theme writer would be good here to fit the clues to the theme. You should balance the method to the age and experience level of the troop. Too easy and it becomes a foot race, too hard and someone will have to go looking for the "Lost Patrol" It's a good idea to run the method(s) you pick out by a few people first.

The End Game

"They were tired..... The Eagle Patrol was laying in the ditch by the side of the road barely moving. Then Greg yelled out "I know what it is! I know what it IS!" The Eagles rose as one and started jogging to the end of the course. Greg had the key to unlock the treasure chest"



Making the adventure worthwhile...

A wide game can cover a long distance from a few miles to a weekend adventure. The Scouts can soon get tired of walking. The end game, a final big challenge at the end of the day, motivates the patrol to keep going.

As each station teaches skills, they also give out clues to the overall puzzle. These clues can range from a phrase repeated at every station to a hand out containing a riddle, clue, or definition. You can use props, posters, flyers, various artifacts (like keys, maps, etc.) and so on to build up the mystery surrounding the end game.

The best example of a successful endgame is when every patrol wants to complete it, even if they came in last place.

Costumes and Role Playing

“He was clad in a old brown monks robe with blue green hair flowing over his shoulders. On closer inspection, the hair was more like rope fibers and the robe was oddly decorated with Atlantian symbols. He commanded the scouts to plunge into the pool to recover the Stones of Alabar and stack them at the opposite end of the pool.”

The Icing on the Cake...

Costumes and role playing elevate the wide game to an unexpected level. When the patrol reaches the first station and are met by someone in costume, pretending to be an old prospector or a spy, they are brought completely into the world of the game! It's easy and fun for the Venturers as well to perform the roles at each station.

One very important consideration when discussing costuming and role playing is notifying the local gardai/police.

There is the slight possibility that one of your parents wearing a black cloak and wandering through the town cemetery attracting groups of young people is going to draw unwanted attention. A quick phone call about a week before the event to the local gardai/police will ensure station performers are not arrested or required to explain themselves.

Costumes

There are two types of costumes required for the successful wide game; performer



costumes and participant costumes.

Participant costumes are used to identify each patrol and consist of a simple item or two that can be easily spotted by the route staff and station/base leader/staff. Some items are neckerchiefs, hats, arm bands, pouches to carry items handed out in the game, and so on. If you color code the patrol costumes you can use the same color code for instructions and clues, props, and so on through out the game. These costumes are simple and easy but make life much easier during the game.

Costumes for the performers, route staff , and other members of the crew should be more elaborate. Each costume should be appropriate to the role that the performer is going to play. Within each theme, there are many different costumes and varieties of costumes. For example, In the Time Machine theme, some of the crew would be modern dress, some dressed like in the past, and even some “Time Police” in a futuristic costume.



The important thing about costumes is that they can be as elaborate or as simple as necessary as long as they fit within the framework of the game. Many people can

add a toolbelt and a red bandana to a pair of jeans and a work shirt and become "Robert - The Time Beacon Repairman" The game was based around the Atlantis Myth and could have togas and Goddess costumes .

Role Playing

- Always explain the role playing idea before asking for volunteers. Wearing a toga in the local park spouting Plato may not be for everyone.
- Never think someone will not do a good job. The most reserved of people can become the most fearsome Pirates you can imagine!
- Always have theme writer work closely with each performer so that they both take part in the process. This allows the performer to improvise as necessary.
- Always have someone who can jump in, in case of a last minute change in performers. All great actors have an understudy.
- Never take this too seriously. No matter how little experience role playing you have, you're going to have a great time!
- Always impress on all the station/base performers that the role they play will enhance the game tremendously. They will come through for you!

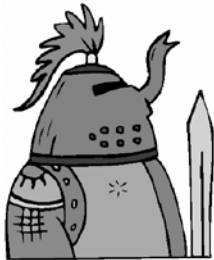

Castaways - Best suited for a wilderness camp out, the wide game starts with no shelter or supplies. Everything the scouts need is natural (or planted) and they need to hunt for it. Events consist of solving problems using pioneering, woods tools, and the like.

Spy vs Spy - Events pitting one group of spies against another. Great theme for codes, signaling, observation skills, & navigation. The spies try to gain enough intelligence information to unlock the secret device and return the "whatever" back to their home base.

Lord of the Rings - A theme set in a far away land - The events become tests of fortitude and skill, the first patrol back has to find the Ring of Power in its hiding place.



Olympics - The events have a sports oriented theme with gold, silver, and bronze rewards. The End game here might be a decathlon with some athletic and some "cerebral" events,

Quest for El Dorado - Follow one lead after another, meet challenges and gather clues to unearth the fabled lost Treasure of El Dorado. Quirky prospectors and various persons give out information to the Treasure Hunters who can meet their tests.

Sample Themes

Paramedics - A series of injuries, disasters, and challenges with a First Aid, Emergency. The Scouts go on call after call to different stations and then face a huge final challenge in the End Game.

Special Unit (Troop Number) - Train to deal with story book/mythical villains (medusa, sandman, trolls, etc.) Gather clues from sphinx, gnomes, harpies, etc. to confront the "great evil."

Quest for the Hol(e)y Grail - Pass the many tests to advance to the room where the Grail is stored. The End game is simple - get into the room and find the holey grail (the one with the hole in the side).

Survivors - Watch the show -borrow the immunity and reward challenges -it's almost too easy!



The Dirty Dozen - This is a great old movie! Learning and repeating the rhyme alone is well worth it and a good clue device for any theme!

Pirates - The patrols start out pursuing the pirates but it turns into a hunt for buried treasure! Old weatherworn maps and X's all over town give this theme it's appeal.

Jurassic Wide Game - Move the Scouts back in time to deal with dinosaurs and earthquakes. Jurassic plant & tracks identification are a great skill for this theme.

The Time Machine - Using the H.G. Wells machine, the scouts travel back to England at the turn of the 20th century. They meet Baden-Powell and go from there to find the materials necessary to rebuild the machine to return home.

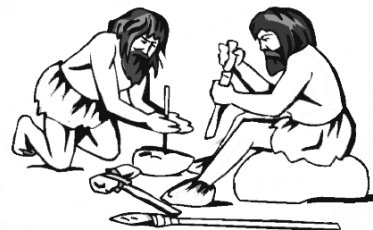

Rafting

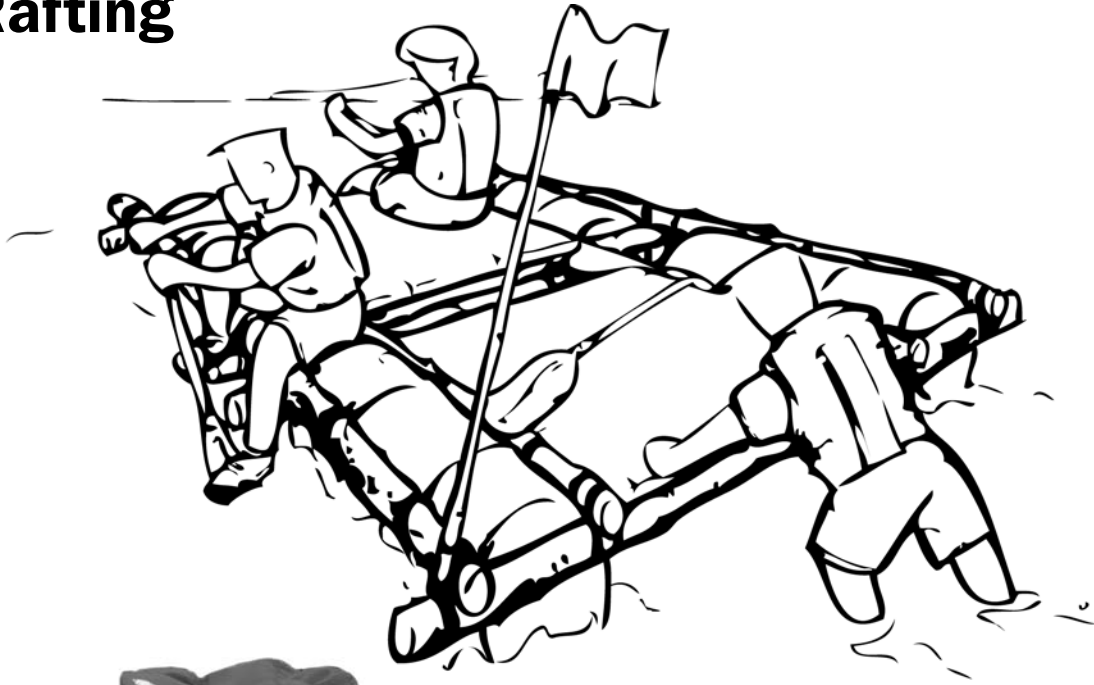

Rafting is an ideal activity for a Venture Scout section. It is relatively easy to organise and requires very little specialised knowledge.

Like all activities on the water you need to observe water safety procedures - the wearing of life jackets and the use of the buddy system is a must - no exceptions to these rules. If you are building rafts outside of the summer months you need to consider the water temperature and therefore you may need wet suits and protection from the elements.

Raft design is simple, and anything goes. We have reproduced here raft designs that work, and are easy to make using basic scout skills such as knots and lashings.

Make sure it floats

You will need buoyancy of some kind, usually sealed barrels are best and can be easily obtained. You could also use plastic sheeting and internal frame designs. You might also consider going to a local campsite, who may already have all the equipment you require - so that it is straight down to business.

The weight of the people on the raft will dictate how many barrels you need. If you are going for a six person raft you are going to need a lot of barrels and poles. It is generally more fun to have two or three small rafts rather than one large one.



Inner tube raft

There are a number of designs you can try. You need large inner tubes of course. These can be obtained from a tyre supplier. A good choice is a supplier that deals with tractors and trucks. In order to get the best use from the inner tubes lash them to a base board and then cover the whole craft with a plastic sheet or tarpaulin. This makes your raft more stable and easier to use.

Paddles and sails

You will need a paddle of some sort. It is best to use a standard paddle rather than a home made one. However, it can be fun, particularly during a raft race when your paddle starts falling apart.

Sails can be introduced if you wish - if there is an off shore breeze. The design of your raft needs to accommodate this possibility so that a mast can be fixed to the raft. You will also have to work out how you are going to use the sail to good effect.

The outrigger raft

This raft is made stable by the use of outriggers. The one illustrated is made from logs but in practice unless you have the right sort of timber this raft is very heavy and hard to use. A similar design can be made using a central core of barrels lashed to an outrigger frame.

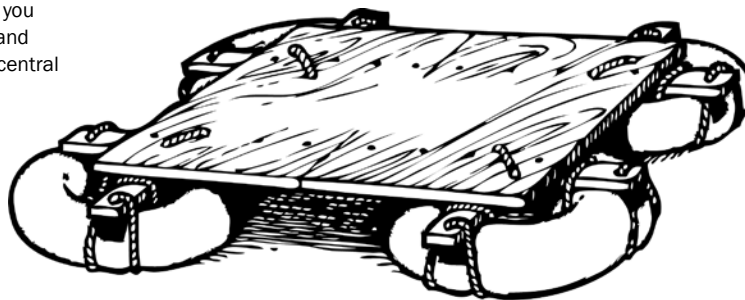
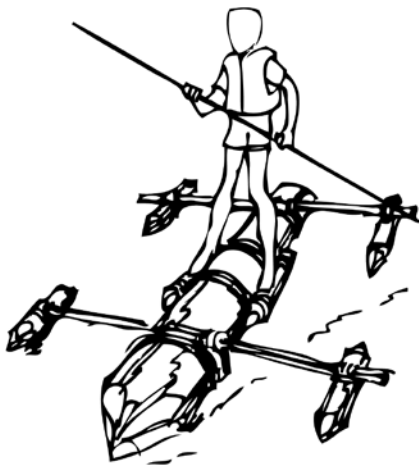

Resistance

Water resistance is a factor that need to be considered. The front of your raft should present little resistance to the water. In order for this to happen you need to create a point in the front to direct water around your raft. The 'flat top' end of a barrel is not great in this regard and often you will need to make a devise to reduce the resistance.

The best method of overcoming this problem is to design the main frame of the raft so that the barrels are set slightly back from the front so that parts of the frame can be used to redirect the water flow.

Street Theatre

The object of the street theatre activity is to allow the members of the Group to express themselves through the performing arts. The idea is for each member of the Venture Unit to choose one of the items suggested and put together a small act that would last for about two - three minutes. The performance should be presented in street theatre fashion just as you would find artist performing in our main shopping streets or at fairs.

Below are listed a few suggestion to set you on your way. These ideas are based on performances observed over the years, it is not the complete list of possibilities, your imagination will come up with more I am sure.

In performing any stunts or playlets in the street theatre environment you should at all time put humour at the top of your performance list.

Mime

Mime is the skill of presenting a story using nothing more than your body and the gestures you make. If you get the opportunity, you should study a mime artist performing to observe how it is done. Below are some playlets you may like to convey to an audience.

The window pane

You and a friend work for a glazier and have to carry a large pane of glass up a busy street and then place it in a window.



The operation

A popular stunt using a back light and a sheet is the 'Operation'. In this stunt a number of shadows are seen suggesting we are in an operating theatre - a doctor, a nurse, a syringe, a patient. An operation is then performed and all sort of objects are taken from the patients stomach. The more ridiculous the objects the better.

Getting out of a room

You are trapped in a room. You cannot see the door and must find your way out of the room by feeling around the walls and the objects in the room.

Chewing Gum

You have got on a bus or train. There is no seats so you must stand in the aisle. You place your hand on the rail for support. You feel something sticky on your hand. You try to remove your hand but it is stuck to chewing gum. You try to remove the chewing gum and in the process

get chewing gum everywhere and on everyone in the train / bus.

The Spider

You spot a spider. Oh! a little spider, you let it crawl up on your hand. The spider crawls up your hand over your chest and down the other side. It does a number of tricks. After a while you get bored and start to pull off its leg one at a time, until you are left with the body. This you now roll up in your finger and flick it away. (A bit crude but good for a laugh)

Puppets

Puppets can be used in a number of ways. They include a light show using cut out figures or shadows. Or if you can manage it a puppet doing a dance. You could make a number of walking ducks who perform walks and dances to music.



Street Band

• A number of instruments can be made from bits and pieces. A band is formed and a performance given.

Side shows

Some other ideas based on side shows.

Poetry recital

A list is given and the performer can perform any of the poems or extracts from literature on the list. The recital should be as animated as possible with different voice for different characters. Or by being excited, romantic, or sad depending on the poem being recited.

Fortune telling

A stall can be set up with a deck of cards and a crystal ball. It will involve the performer learning some simple fortune telling skills - your local library can help.

Limbo dancing

A limbo dancing frame is constructed and a number of performers dance around the frame. Every couple of minutes the bar is lowered, and each member limbo dance under the frame, until it is impossible to get under the frame.

Yo - Yo

A performance can be devised based on Yo -Yo tricks. Yo-Yo's are easily obtained in toy shops.

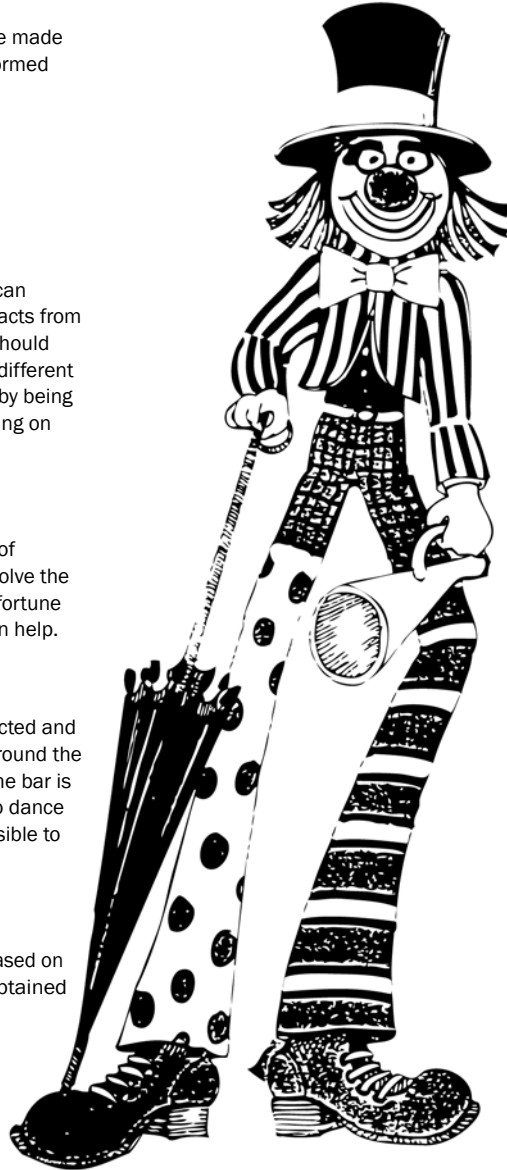

Magic

Have you a flair for performing magic tricks. A number of tricks should be selected and practiced until perfect. Then put on the show.

Strongman

The performance involve doing weight lifting tricks and such things as ripping telephone books apart. You could also have a 'Wimp' show where by a skinny wimpy person tries to be a strongman. He could do such tricks as » ripping a piece of paper in jj half or lifting milk cartons etc.

Tap dancing

An act could be devised where by you set yourself as a tap dancer - top hat tails, cane etc. but when it comes to doing the tap dance you drop a tap out of your pocket on a string and dance the tap on a board.

Stilt Walker

Construct short stilts and dress up in costume, devise a number of tricks to perform.

Orienteering

The simplest definition is that it is finding your way from one point to another, using only a map, a compass and your brains. Orienteering is usually done in the woods, with the participants on foot.

As Scouts your Unit would have learnt the basics of map and compass work. This will have been used to effect on many hikes and camps. Within the Venture Unit programme it is important that scouts skills are improved and revisited from time to time. This can be done by way of formal training sessions and by experience. In the case of map reading, this skill should be used at every opportunity when planning and taking part in adventures. Orienteering is a sport that utilises the skill of map reading in a fun and competitive way. It is a good activity for Venturers as it can be done individually or in small groups.

At a typical organized orienteering event, several courses of varying difficulty are laid out in the woods by the event organisers. Each course consists of a series of checkpoints (or "controls") marked by a brightly coloured, distinctive orienteering flag. Participants are given a map with the locations of the checkpoints circled. The starting place, the sequence in which you visit the controls, and the finish location are also shown. Then, using the map and a compass, it's up to the participant to find his or her way from one control point to another in the order specified.

At each control, there is a paper punch that makes a distinctive pattern. The Orienteer uses that to punch a card, which



proves that they've actually been to that control point.

Orienteering can either be a race, or a casual recreational activity, depending totally on your own attitude towards the event - and at typical events, you will find people of all inclinations and athletic abilities.

There are usually several courses at each event, and they vary in difficulty. What differentiates them are the length of the course, and the placement of controls. So the course for experienced Orienteers might be 8-12km (4-6 miles) long, and finding the control markers would require advanced navigational techniques and an experienced pair of eyes reading the map. On the other hand, the course for beginners would only be about 2 - 3km (1 - 2 miles) long, and the controls would all be displayed prominently near paths. The other courses fall somewhere between.

There are variations of orienteering that are also popular, such as Mountain bike Orienteering, relay competitions, and Night-O.

White course

The White course is the easiest standard orienteering course. It is suitable for adult and teenage novices, as well as for younger children who have developed the necessary skills. It is usually two to three kilometres long, just about right for a short hike.

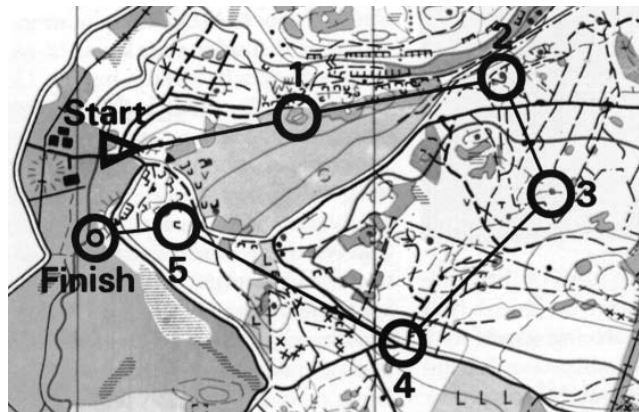



Control markers on a White course are placed on major features such as trail junctions, streams, buildings or clearings. Navigation takes place along trails or streams, through fields, or in other simple areas.

Teenagers and adults should try the course individually or in groups of two or three at most.

Advanced courses

Yellow is the next more difficult course after White. It goes mostly along trails and in easier areas, but has controls on features just off a trail or otherwise in a little more difficult places to find. It is usually three or four kilometres, just a bit longer than White. Teenagers and adults are usually ready to try the Yellow course after one or two times on the White course.

The Orange course is an intermediate course, which goes off trails and into the woods, although it usually uses more obvious features or features near bigger features. It is four to five kilometres long, which is long enough to put an emphasis on fitness.

The Green, Red and Blue courses are expert courses. The longest, Blue, can be ten kilometres or more.

Orienteering skills

The best way to learn or teach orienteering is to do it, so by all means get out onto a map! An orienteering event organized by a local orienteering club can often be the best way to get a good suitable course and map, and yield a rewarding experience.

Learning to navigate

Navigation is the quintessential skill of orienteering, and it will take time to master. Be sure to teach (or learn) it progressively in small steps, allowing for success at each stage.

Don't worry about choosing the best route or the fastest way, just successful navigation.



The Problem of Survival

Imagine yourself with a walking party. There is a blast of wind, a lot of noise and you are engulfed in an avalanche of snow. You are sailing in a yacht a heavy wind blows, you lose your mast and are set adrift. How do you cope?

These situations are ones which people have found themselves in on occasions in the past and will, doubtless, find themselves in the future. For this reason a knowledge of survival can be as useful as a knowledge of first aid.

Although we live in a relatively civilised environment the ease of modern travel, coupled with the fact that Venture expeditions are going to more remote areas, maintains the need for a knowledge of survival skills. In certain respects the need is greater than ever before. Sixty years ago the frontiersmen, explorers, etc. were automatically prepared to spend a long time on a trek. There was no real worry if an expedition planned to last a month took two, since food could continue to be shot as long as one had a rifle and ammunition. Now one can exchange the comfort of home for an unexpectedly cold, hot or otherwise different climate in a matter of hours and without the benefit of the right clothing or equipment.

Before going further it may be as well to define the term 'survival', I suggest that the following is a reasonable definition. 'Survival is the art of remaining alive in and escaping from a hostile environment, without full facilities.'

This needs a few words of explanation. If you camp in the Scottish hills in winter with a good mountain tent, a warm sleeping bag, a stove with plenty of fuel and no shortage of food, this is camping

not survival. Survival begins when some relatively essential item is missing and becomes more acute the less one has.

Trying dehydrated food or using improvised camping equipment are useful skills for survival but not survival in themselves.

Those who remember the Backwoodsman and Pioneer Badges with the requirements of skinning and cooking a rabbit, building a shelter from natural materials, etc. may well agree with this point. The American Rescue Service has said that country people or city people

who have had a lot of Scout training are the best survivors.

It is important to analyse the problems before trying to plan any system of progressive training. In survival there are material problems and mental problems. The material problems can be sub-divided into the need to stay alive and the need to escape from the hostile environment.

To stay alive the following must be considered

Food

Without it one will eventually die although not as rapidly as one might think. In her book. Hey I'm Alive, Helen Klaben describes how she stayed alive for forty-nine days on virtually nothing.

Water

With no water available a man, even in a cool climate and doing no work, is

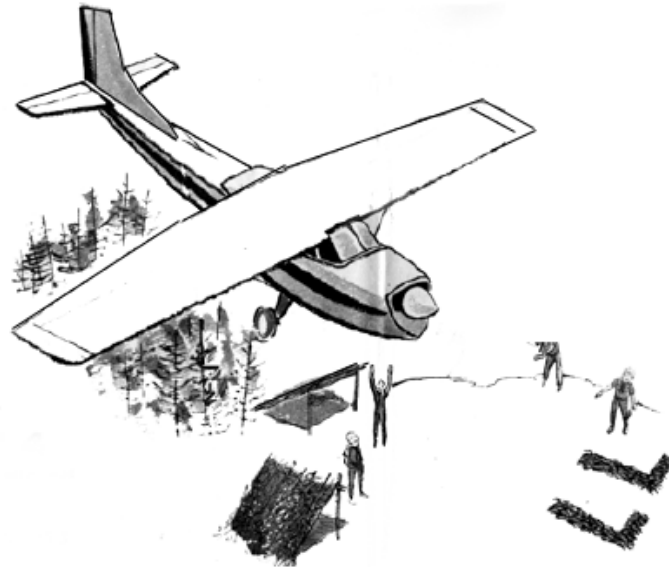

unlikely to survive more than fifteen days. However, if the man can find two litres of water every day he should survive much longer. Exactly how much will depend on his activity and rate of sweating.

Shelter and Warmth

Without these the physical condition of the survivor will deteriorate.

Medical

Untreated injuries or sickness will undermine the body to some extent especially if allied to a lack of shelter and food. Additionally the ability to escape on foot will be inhibited.

Communication

A person is a very small object and the earth is a very big place. Some means of attracting attention is vital for anyone in need of help. A mobile phone is excellent if a signal is available if not then traditional means of communication will need to be used. A satisfactory solution to these matters is not the final answer. The survivor will remain alive but may never get away. While not entering into the argument as to whether or not one should leave a large marker such as a crashed aircraft, upturned boat, etc. there are likely to be occasions when a survivor will

have to get himself out of his difficulties. To the five factors given above must be added the following:

Movement

How to move, when to move, etc. now become vital questions to be answered.

Navigation

This may not be to one-degree accuracy but in many types of terrain it is quite an effort to keep going in a constant compass direction without veering well off course. Walking in circles is not just a travellers tale.

Load-carrying

Too big a load will reduce your chances of reaching help but too small a load may mean vital items are abandoned. The load must be carried as efficiently as possible if a lot of energy is not to be wasted.

The solution to material problems can be summed up In three words -training, testing and experience.

Training can be achieved by regular discussion with others, and working out your own solutions with members of the Venture Unit. By working through

and testing methods and ideas you will determine those which appear to be the most satisfactory but you should beware of discarding a technique completely, since many techniques are not geographically universal. All ideas should be tried: nothing is too insignificant as a survival possibility. Survival could well be described as 100% attention to the detail of living. Experience of the techniques will give confidence in their use and, more important, confidence in one's own powers of survival. A Scout of any age can try building a shelter from natural materials and spend a night in it. The difference is that for an eleven-year-old there is a nearby hut or barn if the weather turns rough but for the sixteen-year-old there is not. The next test is to try it in winter .

Material problems are easy to find a solution for since one is dealing with tangible things. It is the mental problems which are less easy to solve and training for them is more difficult, but one mental factor, the will to survive is paramount to overall mental and material considerations. In considering the psychology of survival a Dr. Seyle has described the stress syndrome. There is not the space here to consider it in more



than bare outline but the following points may be worth pondering.

The Will to Survive

The trump card in survival. With it almost anything is possible, without people have literally turned their face to the wall and allowed themselves to die. It is an amalgam of a man's personality and almost everything in his life, good and bad, will affect it. His home upbringing, school, job, success or failure, religious belief, moral standards are just a few areas of influence. The value of a good Scout Unit over a Scouting life of, say, ten years is easy to see. The will to survive must be based on confidence in oneself to cope and how much easier it will be to cope if one has practiced coping before.

Group Behaviour

Most people will survive better as a group. The fear of letting one's friends down or being seen to be weak is a wonderful force to survive and work together.

Activity of Mind

Stress is reduced by occupying the mind as far as possible. Everyone in a group should be allocated some task, however small.

Conservation of Resources

Notwithstanding the last comment the ability to 'switch off' and husband one's physical and mental resources is very valuable.

Decision Taking

Indecision in a Leader will generate stress. When a decision is taken the stress is reduced but unless the Leader communicates his/ her decision and their confidence to the party stress will remain in the members. It is vital that everyone knows what is going on and has a chance to ask questions or voice their opinions. Most survival situations are likely to occur as dramatic change. The well-planned expedition suddenly

meets a crisis which was unforeseen -the boat suddenly breaks down, the aircraft suddenly crashes. The sudden shock is a very damaging blow to a persons mental stress stability and the strange situation gives rise to a host of fears in everyone. In a situation like this the person who says that they are not afraid is either a liar or a fool. Both should be avoided. Fear of the unknown can easily be understood. It is Inherent in all of us and can often be seen in animals. It might well be said that we live too comfortably. Central heating, plenty of food, the provisions of the welfare state .This has lead to a state of mind which does not accept discomfort happily, and many people have a real fear of discomfort. In a tough situation some will begin to fear others in the group. Dark forbidding mountains, gloomy stretches of water can readily induce fear and give an overpowering sense of foreboding.

Previous knowledge of survival techniques, self confidence, good leadership coupled with an strong determination to survive will produce the best chance for anyone, anywhere.

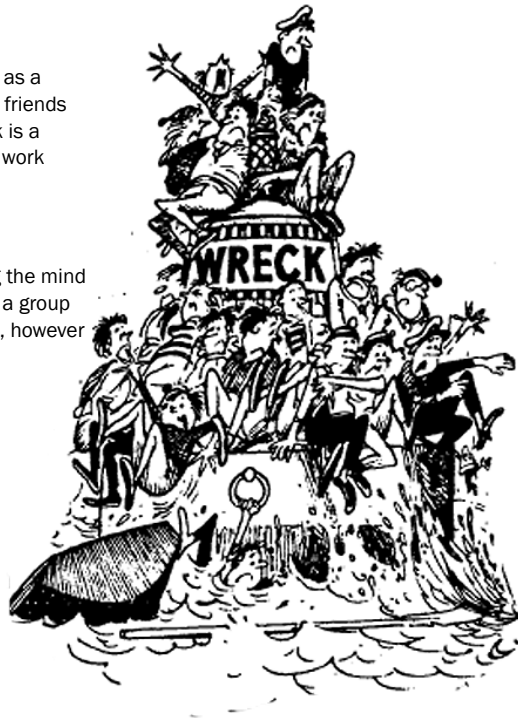

World Trade Game

Introduction

The aim of this game is to help the participants understand how trade influences the development of a country and to create interest and discussion about the world trading system in an enjoyable and non-academic way.

The earth is divided into two parts: The economically rich north (industrialised countries as the US, Japan and Europe) and the poorer Global South (meaning Africa, Latin America and parts of Asia). There are many ways of explaining the differences between North and South but one thing is clear. The gap between rich and poor is becoming bigger partly because of the world trading system we have today which makes the North richer at the cost of the South.

The game will try to show, through the production of different paper products, how the world trade works. How do countries interact? Who are the winners? Who are the losers?

Who can play?

The game can be played by anyone preferably over the age of 14. The number of participants should be between 15 and 30, if the group is bigger than that you can run two games at the same time. The rules are simple and the knowledge you need to play is elementary.

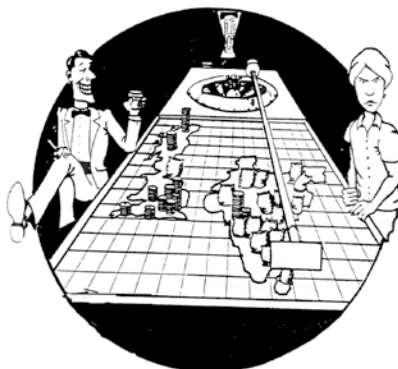

Time and place

You need at least an hour for the game including the discussion afterwards. You need a room big enough for 6 groups with around 4-6 participants in each group. Each group needs a chair for each participant and one table. There should also be space to move around between the groups.

Preferably 6 groups divided into the 3 different categories (see below). If you use

Group	Players	Countries	Equipment
1 and 2	6	UK, Italy, USA, France	2 sets of the following:- 2 pairs of scissors, 2 rulers, 1 compass, 1 set square, 1 protractor, 1 sheet of paper, six 100 dollar notes, 4 pencils.
3 and 4	5	India, Brazil, Peru, Nigeria	2 sets of the following:- 10 sheets of paper, 1 sheet of coloured sticky paper, two 100 dollar notes
5 and 6	4	Tanzania, Kenya, Burma, Ghana	Two sets of the following:- 4 sheets of paper, two 100 dollar notes, 2 pencils

Equipment

For 30 participants you need:

- 30 sheets of A4 paper in the same colour
- 30 '100 \$ notes'
- 2 sheets of coloured paper
- 2 tubes of glue
- 2 pairs of compasses
- 4 pairs of scissors
- 6 rulers
- 2 triangles
- 14 pencils/ pens

less than 6 groups make sure that the balance between 'technology' and 'raw material' stays the same.

The game organisers need a table, a blackboard, and some spare pens, papers and 'money'.

Ready to Play?

All participants must be able to see the models of the products they are producing (see page 89). Draw the models on a flip chart or on big sheets of paper.

The game needs three organisers:

Two bureaucrats in the World Bank. The bank's job is to quality check the products and write down all the deposits in the different bank accounts as well as adding 10% interest every 10 minutes.

The game's facilitator - UN. The facilitator's role is to lead the game, observe how things develop and sometimes change the development of the game by introducing new elements. Because the facilitator is also supposed to lead the discussion afterwards it might be helpful to write down everything that happens; comments, happenings etc.

The Rules

All products must have sharp ends, be cut by a pair of scissors and have the exact size.

When you have produced 5 examples of one product you can present this to the Bank. If the quality is good enough the amount of money your products are worth will be written down in your bank account.

Every 10 minutes the Bank will add 10% interest to the amount of money already in your account.

You are only allowed to use distributed resources and equipment.

You are not allowed to use physical force or violence.

The facilitator, who represents the UN, will mediate in case of disputes between countries.



Only what is already in your bank account when the game ends counts when the result is summarised.

Instructions for the facilitator

Explain the aim and rules thoroughly. Answer questions but make it clear that you will not answer any questions when the game starts.

Divide participants into 6 groups and give them their countries' resources.

In the beginning there will be confusion and you'll get a lot of questions; "Why don't we have any markers?", "What is the coloured paper for?" Remember not to answer any questions. Make sure all the initiative come from the participants and not from you.

The production and trading may last for 30-60 minutes, it all depends on how interested the groups are, their activity and initiatives.

What to produce?

These are the 5 different products the groups can produce. When you have produced for example five triangles you go to the bank for quality check and if they

are good enough you will get $\$150 \times 5 = \750 into your account.

For the Facilitator (important points during and after the game):

Notice everything that happens

The category "A" countries will probably start producing goods at once but they will run out raw material (paper) quite soon. Then they will have to try and get hold of more paper from the other groups. Because you are the only one that can see how the game really develops it is important that you notice how alliances and trade conditions change throughout the game. Use your observations in the discussion after the game. Take notes.

Stimulate activity

Sometimes the facilitators have to give additional information and try to create new situations. Some of the information can be given to the whole group while some information will be given secretly to some countries. Remember to inform the bank about all the changes you make. Not all the elements below need to be implemented in the game. You have to see how the game develops and how much stimulation is needed.

Some examples

Price-changes on the global market

After a while you can change the price of some products. That way the rich countries for example will find out that their compasses are not as useful as they used to be. From this you can draw parallels to the real world: When a country finds out that their technology is getting out of date they usually sell it to poorer, less developed countries. The prices can also drop if there is an overproduction of one product on the market.

Raw materials

You can for example give a bunch of papers to one country and then announce for "the whole world" that a new source of raw material has now been found in this country.

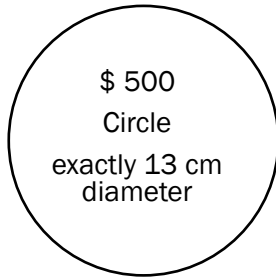
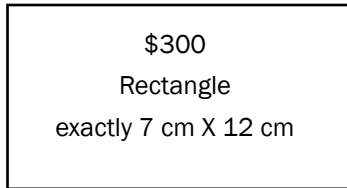

The sticky paper

Two of the groups have a coloured sticky paper. They have no idea what to use it for. This represents an unknown natural resource. You can make it known for two other groups, e.g.: If you stick a little piece of the colored sticky paper on to your normal products the price of those products will increase 4 times.

These two countries will then start searching for the coloured paper. Because the country that owns it doesn't know the value of it they might sell it really cheap. (Like Zambia sold the rights to exploit and export copper to Rhodes in the late 19th century.) Or they get suspicious and won't sell it.

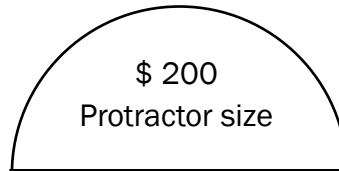
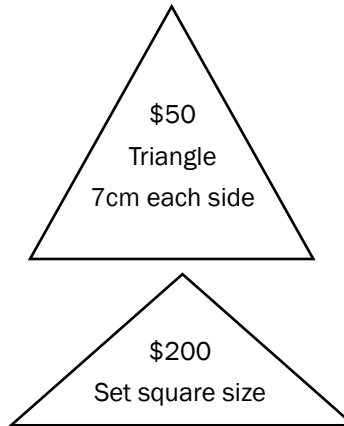

Ideas for discussion

Fair trade

Some of the participants will probably get accused of cheating. That gives you the perfect chance to discuss moral issues and ethics in international business.

"It's not fair!"

Hopefully the participants will point out this fact quite early. After the game it is important to use this statement and together try to find out:

What was not fair about the game?

What does the game tell us about the real world?

How does it feel to be rich?

How does it feel to be poor?

Why is it so difficult to change an unfair system?

Who owns the world's natural resources?

Who owns the world's technology?

Try to move the discussion from describing how the world is today to how the participants would like the world to be. Try also to make them discuss the moral responsibility that goes with wealth.

Shapes

All edges must be cut with a pair of scissors and be measured correctly. Shapes which are not exact will be rejected.

Why expeditions?

Expeditioning is a vital ingredient of the life blood of any Venture Scout Unit. Why is it that those Groups who go on expeditions as a regular part of their annual programming are usually the most successful Units and why is it that those who don't have an expedition are missing out on all the action.

Why is this so?

What does an expedition do that provides that spark in your Venture Unit's programme.

- Scouting is about the business of living together.
- Scouting provides an opportunity to test values.
- Scouting provides a challenge to the individual which will be demanding
- Scouting provides the expertise for such demands
- Expeditioning is about the business of living together
- Expeditioning provides an opportunity to test values
- Expeditioning provides a challenge to the individual which will be demanding
- Expeditioning provides the expertise for such demands

What is an expedition

If one looks at the word in the dictionary, expedition really means going out on foot, so, for the Cub Pack it means going for a walk in the local park. For the Venturer



Scout Unit it means walking from Dublin to Galway in a straight line. The word, of course, has much wider connotations than this. It really means any form of activity that requires travel and going away from our normal environment.

Expeditions compliment the standing camp and it is probable that the values of the standing camp can be incorporated into a well run expedition. The expedition has however more to offer the Venture Scout Unit and suits smaller numbers and experience of travelling light with everything you need in your pack.

What type of expedition

There are three main types of expeditions: That which tests the physique and for want of a better name we call the "The Back Breaker".

That which test the mind and for the want of a better name we call the "The Head Sweller".

That which is for fun which we call "The Crack"

It may be that your expedition will be exclusively one of these types but generally speaking, all expeditions will include all three categories. It seems to me a good thing is that to rotate expeditions so as to have a preponderance of one of these categories year by year- there by satisfying the needs of all members of the group. There is a great danger that an overabundance of particular activity whether it be mountaineering, boating or visiting cathedrals may make the expedition exclusively open to those interested in those activities and may exclude those who are not. Therefore an expedition

having a wide variety of all these activities will ensure greater harmony and participation.

What value is it to the Venturer Group

Without doubt, the proper planning of the expedition will take time. There is much to organise, considerable research may have to be undertaken, finance raised, people contacted, parents informed, expeditioners trained, food accommodation, transport all arranged and lots more.

It is in all of this that the greatest value of an expedition is realised and that value is involvement. Young people are trained by taking part in the processes connected in the mounting of an expedition and, of course involving everyone means that the expedition becomes part of the week by week programme. Therefore, good leadership from leaders and from the Executive Committee will seize the opportunities which expeditioning provides for filling the programme with worthwhile training items. The group can be seen to grow in stature as it co-ordinates its thinking and activity towards an ultimate goal. The expertise learned throughout planning an expedition and whilst on expedition will form the tradition for the next stage of the groups life. Such expertise becomes traditional and is handed down thus ensuring the growth of the Group in interest, knowledge, experience and achievement.

What does the expedition

offer to the individual.

Good co-ordination throughout the expedition enables the individual to test himself/herself against standards that have been set. It provides a goal to be reached; it gives a sense of achievement. It helps an individual to fill an important part of the Group through dependence and support, one for another. Qualities of leadership are brought to the fore, the ability to fit into a team will be developed; learning to live tolerably with ones companion in circumstances that may not be comfortable and learning to be responsible and reliable are all processes that an expedition can engender. Any young person will find his/her imagination fired by good expeditions and this enthusiasm for reaching out can not be dampened once experienced.

What have expeditions got to offer the leader

A good expedition, as can be seen from what I have already said, provides a multi-plicity of opportunities for training young people expedition planning and organisation provides a tremendous amount of material for training purposes which, in turn means that programme planning becomes easier, more imaginative and interesting. All young people need to feel week to week, that they are making progress and progressive planning for an expedition will enable this process to happen. Leaders need to study carefully

the details relating to expeditions so that they can pass on this information and help direct their Group as they themselves discover what to do.

A good expedition, well organised and run, will be one of the most memorable things that a young person undertakes. It is up to leaders to encourage the process within their own Units. It is up to leaders to be bold and undertake expeditions as a regular part of their annual programme. With it the Unit will succeed-without it, in my opinion, it fails.

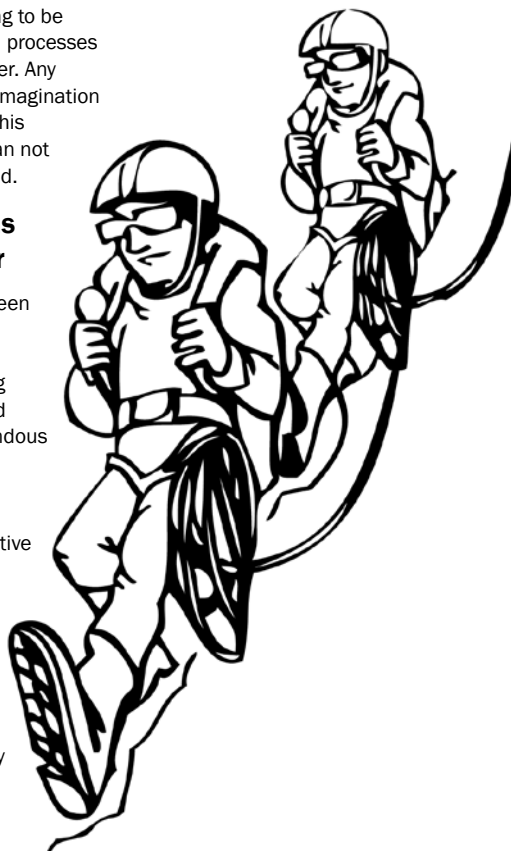

Some expeditions to explore

The Burren

This expedition involves a number of elements. The first part of the journey brings you across the Burren from Ballyvaughan to Doolin. From Doolin we travel by ferry to the Aran Islands and explore each island in turn. Lastly we return by ferry to Galway. This expedition will take up to 10 days to complete.

- Day 1** Travelling to Ballyvaughan
- Day 2/3** Walking along the Burren Way from Ballyvaughan to Doolin overnighing along the route
- Day 3/4** Overnighing in Doolin, a haven of traditional music and travelling to the Aran Islands
- Day 4-8** Exploring the Aran Islands in turn Inis Oirr, Inis Meain, Inis Mor. This exploration may be done on foot along pathways (Aran Ways) or by bikes hired on the islands.
- Day 9** Return by ferry to Galway - Rossaveal, 42 Kms from Galway) - overnighing in Galway area
- Day 10** Returning home

Travelling to area

Trains and Buses (Expressway and budget buses) operate to the main centres of

population. The best deals travel wise, are on budget buses particularly at the weekends.

A regular bus service exists from Galway to Ballyvaughan from Galway train station

A regular bus service exists from the ferry port to Galway and the surrounding areas.

Details of bus and rail services are available from Irish Rail and Bus Eireann. Local Tourist Offices can advise on other services in the area.

Accommodation

A number of privately owned hostels exist in Doolin, a number on the Aran Islands. On this expedition we suggest that you combine camping with hosteling accommodation. Camping is possible in remote areas along the Burren Way, however, under no circumstances should fires be light , all cooking should be done on stoves, and if possible permission should be sought to camp on land. A lot of hostels also have land adjoining the hostel on which you can camp. This area of the country is extremely popular in the summer season therefore it is advisable to pre book all hostel accommodation.

Food

It will be necessary to plan meals and food stocks around towns you will travel through. Stock up in Ballyvaughan with

supplies to last till Doolin. Stock up in Doolin to cover first day on Aran Islands etc. Careful planning of menus and supply points will ensure the easy replenishment of supplies.

Further Information.

Local Tourist Offices in area
Irish Long Distance Walks Handbook by Michael Fewer
Independent Hostel Guide (available from Tourist offices)
Siuloid Arann: a guided tour of the Aran Islands (available from book shops).



Grand Canal

This route follows a long distance walk way which starts in Hazelhatch outside Celbridge, Co Kildare and runs to Graignamagh in Co. Kilkenny. The walk way has been developed by the Office of Public Works in conduction with Cospoir and follows the towpath along the canal and the river. The level nature of the towpath lends itself to nice easy walking conditions. Likewise, mountain biking is also possible along the trail, or indeed canoeing on the canal and river.

This waterway was built to service the various towns and villages along its way, therefore there is no problem with food supplies. There are many interesting places to visit along the trail making it possible to drop off the trail and return to it at will.

Camping is possible along the trail on the common ground which exists along the towpath. It is suggested that you setup camp well away from large towns and villages so as not to attract unwanted attention and under no circumstances should fires be lit.

Outline of route if walking. If you are travelling by bike or canoe itenerery will differ.

- Day 1** Arrive at Hazelhatch, Celbridge, Co Kildare via Heuton Station Dublin. Begin journey along the way. Get a few miles under the belt - camping perhaps near Sallins
- Day 2** Continue along the way visiting the towns of Sallins, Robertstown and Rathangan - camping near Rathangan
- Day 3** Rathangan to Monasterevin and beyond. Camping between Monasterevin and Athy
- Day 4** Proceeding to Athy. Exploring Athy and camping nearby
- Day 5** Athy to Carlow
- Day 6** Carlow to Muine Bheag (Bagnelstown)
- Day 7** Muine Bheag to Graiguemanagh
- Day 8** Canoeing on River Barrow in Graiguemanagh
- Day 9** Relaxation
- Day 10** Return Home

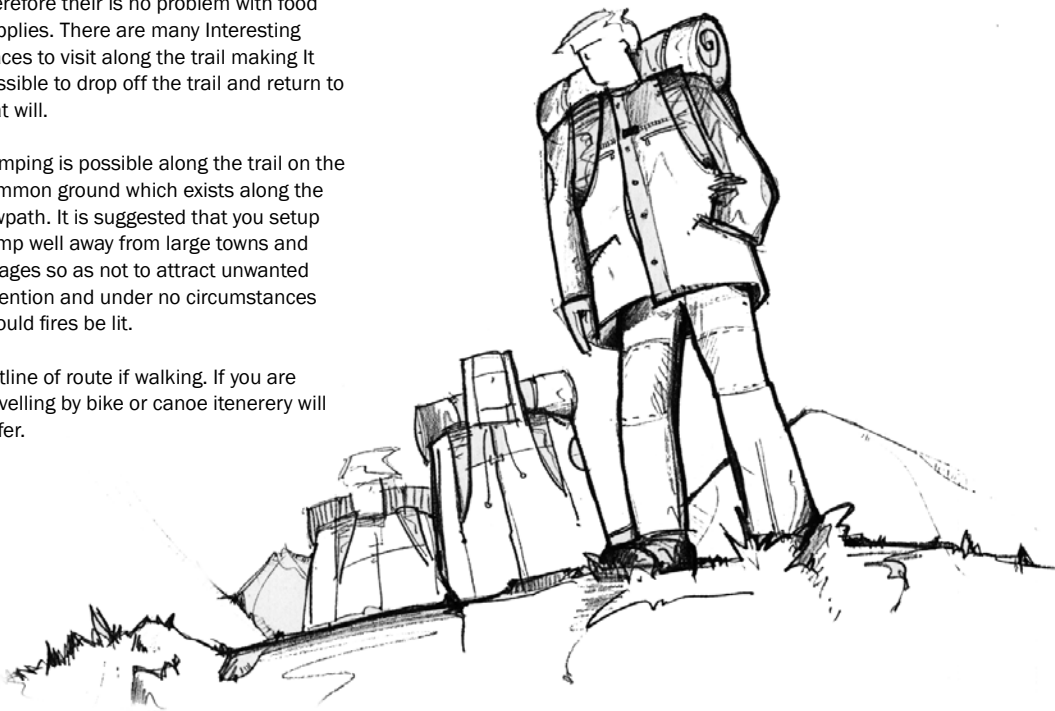

Connemara

- Day 1** Arrive in Westport. Overnight in hostel or campsite.
- Day 2** Climb Croagh Patrick. Arrange bicycle hire.
- Day 3** Cycle to Delphi via Louisburgh. Camp at Delphi Leenane/ Private hostel
- Day 4** Adventure sports activities in Delphi Adventure Centre. Perhaps two sports/activities) Camp at Delphi / Leenane/ Private hostel
- Day 5** Cycle to Maam Cross (restock food). Set up camp at Maamturk valley
- Day 6** Hillwalking along Maamturk ridge. (M.P.C. route). Overnight on ridge.
- Day 7** Hillwalking along ridge. Camping in Maamturk valley.
- Day 8** Cycle towards Westport along Lough Mask and surrounding area. Camping along the way.
- Day 9** Return to Westport. Overnight in Westport
- Day 10** Return home

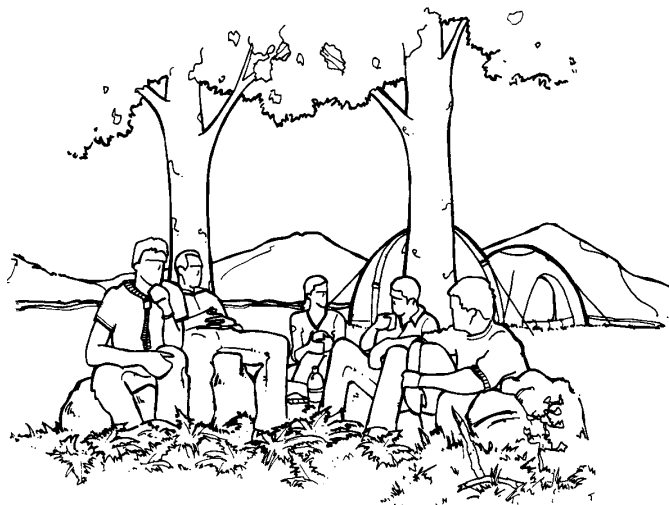

Kerry

There are 3 long distance footpaths in Kerry each way approx 100 miles in length. It will no be possible therefore to do the whole lot in one go. Each way follows a route around each peninsula that makes up the county of Kerry. The countryside is particularly beautiful in this part of the country and of all the walks offers the greatest opportunity to experience the raw beauty of Ireland. It is possible to cover the same area and nearly the same routes by bicycle along ring roads of the peninsulas. It is also possible to cover parts of the route by pack ponies (the ponies carrying the gear). This might be an interesting diversion on part of the route. Details are available from local tourist offices re agents , costs etc.

The 3 ways In Kerry are The Beara Way from Glengarriff to Kenmare. The Dingle Way from Trales to Dunquin and back to Tralee and the Kerry Way from to Kenmare

following old droving paths and coach roads to complete a different Ring of Kerry from that normally seen by tourists.

Travel Distances

The Kerry Ways are particularly long. It is possible to do only portions of any of the Ways as all of the Ways have may points from which you can join or leave the route. In doing any Way or route it is important not to overstretch the capabilities of the Group or the individuals doing the route. Kerry offers the traveller an enormous array of places to visit and see and in doing any route the important factor is to get the mix right and at the same time contain the challenge of the route.

Travelling to area

This area of the country is well provided for by way of transportation. Tralee and

Killarney are serviced by train and bus services. Other towns and villages are served by bus only. Irish Rail and Bus Eireann can provide details of times and services. On the Beara Way there is a cable car service to Dursey Island and a regular ferry service to Bere Island

Food

All of the routes pass through or near to towns and villages where food supplies can be replenished. On certain sections of the route it will be necessary to bring enough food and supplies for 2 days just in case.

Accommodation

There are a number of hostels available in the area from An Oige hostels to privately owned hostels. With careful planning it is possible to avail of hostel accommodation. It is wise however to consider camping as your primary accommodation and supplement it where possible with hostels. There are a large number of privately owned hostels and a variety of An Oige hostels in Kerry.

Further Information

Irish Long Distance Walks by Michael Fewer

The Beara Way Strip Map available from Cork Kerry Tourism

Cork/ Kerry tourist offices in Killarney and Cork

An Oige can supply details of hostels in this area.



Way out West

The Western Way runs from the fjord of Killary near Leenan to the Ox Mountains in north Mayo. This route will take the walker through some of the most magnificent scenery in Ireland. From rugged mountains to the wild and desolate bogs of Erris and Tirawley, from Croagh Patrick to the landscapes of the first farmers of north Mayo and the Ceide fields, passing the ruined grandeurs of Sheskin Lodge and the futuristic windmills that will produce new energy when the bogs are exhausted.

This route is considered to be one of the toughest of the long distance walks - 177 km/110 miles. Certainly there are sections where there are no traces of civilisation for many miles. It is advised that those attempting this be well

prepared for tough conditions (across bogs) and changeable weather.

Travelling to the area

Access to the area is via Galway, Westport and Ballina. Trains and long distance buses terminate at Galway station. It is then possible to get a connecting bus to Leenan from Galway station. It is also possible to get a bus from Westport (summer only) but it tends to go all over the place before you arrive at Leenan. It is therefore suggested that you travel via Galway or alternatively do the routes in reverse from Ballina to Leenan.

The official route terminates in Tobercurry in North Mayo. We suggest however that you terminate your route in Ballina as it offers better opportunity for transport out

of the area or into the area as the case maybe. Buses are infrequent and it is advisable to check with Bus Eireann for times and details. A number of private bus companies operate services from Dublin, Cork, and Galway at budget prices.

Options

Although this route is presented in its pure state it is quite possible to do parts of the Way. Perhaps from Leenan to Westport and then to opt for bicycle hire and explore the rest of the area on wheels. Glenans also have a sailing school near Westport and it is possible to avail of sailing courses there for a week . It is also possible to avail of adventure sports in Delphi adventure centre near Leenan

Food

Food is one of the biggest difficulties on this route. Therefore only major centres of population such as Westport, Newport, Killala, Ballycastle, Ballina should be considered as food replenishment locations. It is possible to drop off the routes to such places as Louisborough and Bangor Erris. However, this will mean travelling there and back which can be some distance. The best option is to plan the long sections carefully and stock up before embarking on these sections of the trail.

Cooking at all times should be by stove. Don't forget fuelstocks.

Accommodation

There are a number of hostels available in the area from An Oige hostels to privately owned hostels. With careful planning it is possible to avail of hostel accommodation.

It is wise however to consider camping as your primary accommodation and supplement it where possible with hostels.

Further Information

The Western Way Booklet is produced by Mayo County Council and is available from them at a fee. The booklet is also available in bookshops.

Glenans Irish Sailing Club can provide details of sailing courses from their headquarters in Dublin.

Delphi Adventure Contra is contactable at Delphi Adventure Centre, Leenan, Co Galway.



The Explorer Belt

The aim of the Explorer Belt is to get to know a different culture from our own and the method is to meet people from the country concerned and to learn about their way of life, their traditions and customs.

The basic elements are a ten day hike covering 200km while living on a limited budget and completing a number of projects along the way.

The Venture Scouts know only which country they are going to. They will not know which part of that country they will be in until they get there. Their parents will be sent a letter on the day of departure telling them where the Venture Scouts will be and giving a phone number at which the expedition staff can be contacted.

An Explorer Belt is not easy from a physical point of view but plenty of preparation will help you when you go. It will also make the Expedition more enjoyable, as you will not have physical problems to worry about so you can concentrate totally on having a good time.

Destination

In September each year the destination for next year's Belt is decided. This can be anywhere except Ireland and, as the decision is based on cost and access, the Belt usually takes place somewhere in Europe.

Venture Scout teams of two are encouraged to take part if possible



and are actively encouraged to seek sponsorship for the expedition.

Once the team are sure that they are going, they should start training. They will have to walk 200km (about 120 miles) over 10 days and they will not enjoy it if they are not fit and have no prepared themselves as much as possible. They should get to know their partner well as the two of them will be relying on each other for 10 days. If either of them has a medical problem, e.g. asthma, the other should learn how to cope with it. They should both know basic first aid, especially how to treat blisters.

It often helps if the Ventures can learn a few words in the language of the country they will be visiting. Even being able to say hello, please, thank you and goodbye can go a long way to getting off to a good start.

There will be meetings/weekends for all participants during the spring and early summer to explain what they will have to

do and to help with any problems they may have.

The Hike

Then comes the trip itself. There are very few strict "rules" about the expedition. The main one is that Venture Scouts may not walk along motorways, main roads or through cities. This is for two reasons the first being their own safety and the second being that people on a country road are more likely to help the Venture Scouts than city dwellers.

The Venture Scouts are dropped off the bus and are handed an envelope which contains the following:

1. A map of the area through which they will walk;
2. A letter of introduction both in English and the language of the country they are visiting;
3. A list of projects, again in both languages;

4. Their budget for the ten days - this will vary depending on the cost of living in the country they are in;
5. An emergency envelop (to be opened in case of emergencies only) which contains some extra money and a "Don't Panic" letter;
6. A letter to them from the expedition leader explaining where the base camp is and giving them the phone number and times to contact the staff.

Once the Ventures have been dropped off the bus they are on their own . The team's first task is to find out where they are . The will probably have been dropped outside a village so all they have to do is ask someone - their first contact. Once they know where they are and where they are going they read the projects and decide which ones they are going to do. Some projects are on serious subjects and may require talking to plenty of people along the way while others are more light-hearted. Some can be decided immediately and others will answer themselves along the way so the Ventures should be fairly flexible about which projects they are going to do.

The teams must keep a logbook along the way giving details about their route, budget, menu and who they met but, as the log book will be their reminder of the trip, anything goes. The projects too must be written up and it is easier for the teams if they do this as they go along.

The important point about the Explorer Belt is teamwork. Both of the team members must have an input to the log-book and projects maybe taking it in turns each day to do the writing while the other pitches the tent, cooks dinner or whatever.

After the Hike

On the tenth day the Ventures arrive at the base camp. There they hand in their log-books, projects and any money left

While the teams are relaxing the expedition staff are reading the logbooks and projects. The teams will know their "tutors" beforehand and each tutor reads the log-books and projects for their own group.

After a meeting of all the expedition staff each team will meet their tutors and the four people will chat in more detail about the ten days. The teams are encouraged to talk about anything they want especially incidents that they could not or did not put into writing. In this way teams who are not too hot in the writing stakes find it easier to communicate their experiences.

Whether or not a team is awarded the Explorer Belt is the decision of all the staff not just the tutors. For some teams it is easy to make the decision and for others it may require discussion among the staff and a longer chat with the team but no one person is responsible for the decisions. This type of assessment is designed to get the best results from each team and the teams will have a good idea, before the presentation, whether or not they have got the Belt.

Once all the decisions have been taken - usually on the third day after the hike - the presentation will be made. This leaves the last few days free for everyone and the programme will usually include shopping for souvenirs as well as whatever activities are available.

The last day has finally arrived and everybody is ready to go home. The

comradeship on the expedition is usually good and nobody wants to leave but some things cannot be avoided.

Teams and staff alike are sad to see the last day but to quote a Venture: "No-one can ever take away the experience of the 10 days on the road. I don't care if we get the Belt or not because we had such a good time, but if we don't, we'll be back next year to try again."



Visits to

There are lots of places you have never been where you can have guided tours. It helps if you know someone who works there, otherwise consult your phone book.

Here's a few ideas to get you started

A Fire station
A Garda station
A Casualty ward
A Newspaper Office
A Biscuit Factory
A Steel foundry
A Glass Factory
A Fish Hatchery
A Winery
A Brewery
A Museum - behind the scenes
A Panel Beaters Shop
A Electrical Generation plant
The Theatre - get someone to take you round backstage after the show
An Airport Control Tower
An Airforce base
The Docks
The Law courts
The Morgue
A Funeral Parlour
A Greeting Card Factory
A Car Factory
A Flower Farm
A Computer Complex
A Television Station
A Radio station
A Bakery
The Cats and Dogs Home
An Orchestra Rehearsal
The Stock Exchange
A Large Bank
The Racetrack
A Forest or Christmas Tree farm
A University

A Mine
A Timber mill
A Cannery
Mail sorting centre
The Weather Bureau
A Railway shunting yard
A Sheltered Workshop
Alcoholics Anonymous meeting
Weightwatchers
The Zoo - behind the scenes
A Circus - behind the scenes
An Observatory or Planetarium
A Science Laboratory
An Artist's studio
Citizen's Advice Bureau
A Sweet factory
The waterworks
A Printing Shop
A Clothes Factory
A Sewerage Farm
An Old folks Home
A Monastery or Convent
A Prison
An Archaeological Dig

Visitors to your Group

The easiest type of meeting to organise is a guest speaker night, because the guest organises most of it. Make sure you introduce him / her properly. Supply everything he/she needs for his talk - projector, blackboard etc. Have plenty of questions and some supper on hand. Don't forget a thank you note.

Here's a list of some people you might like to invite to talk to your Group.

A Priest
An Anglican Minister
A Jewish Rabbi

A Buddhist
A Moslem
A Local Councillor

A Fireman
A Sporting Personality
A Vet
An Army Officer
A Naval Officer
A Pilot
A Garda
A member of the Drug Squad
A Hare Krishnan
An Archaeologist
A Lfjesaver
A Life Boat man
A Doctor
A Blind person
A Farmer
A Diplomat
An Advertising Agent
A Newspaper reporter
A Photographer
A Mountaineer
An Expert on Sex education
A Musician
An Ex - Convict
A Nutrition Expert
A Marriage Guidance Counsellor
A Cartoonist
A Busker
A Bomb Disposal expert
A Nun
A Monk
A Television producer
A Television star
A Trade Union Representative
A member of Gamblers Anonymous
A Parent
A Judge

Lets talk

What are suitable topics for discussion with Venture Scouts. The best topics are those the young people initiate themselves. Often, they lead to an exploration of ideals - the issues of right and wrong and social justice.

There is a great deal to be said for learning the rules of formal debate for the discussion of more serious topics and a well planned, well informed debate can be an interesting part of any programme. The major points to remember when planning a formal debate are as follows.

The most important person is the Chairperson, who should be able to hold a position of authority with a sense of humour and who should have a reasonable knowledge of the subject under discussion.

The subject should be worded in the form of a positive motion

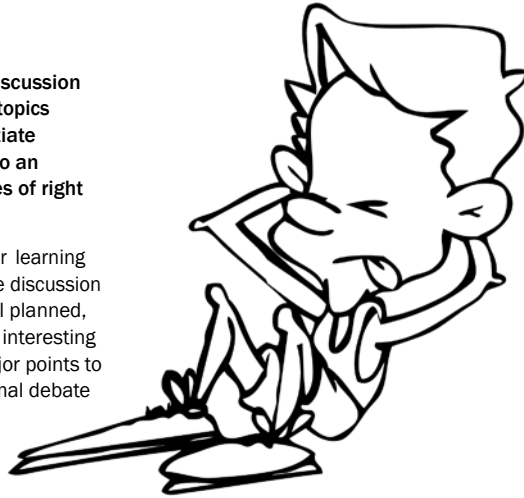

The motion for discussion should be well advertised so that the group can 'Gen up' on the subject matter prior to the event. Or if possible show a video tape of a television programme or documentary before the discussion to prompt debate as everyone will be starting with the same information.

Proposers and seconders should be chosen both to support and oppose the motion. They should be allowed a specific time to talk on the motion. The Chairperson should then throw the debate open for a period to enable everyone to speak.

There is always one person who wants to hog the discussion, so it is advisable to limit each speaker to a time limit of about 3 minutes.

A very important task for the chairman is to encourage people to speak from the floor. This can be done by asking each person in turn for their views if you have a small group.

After about thirty minutes of discussion from the floor the Chairperson should then ask the proposer and opposer to sum up the discussion from their point of view taking on board the points raised from the floor. They should have a time limit of about five minutes each.

All speakers should address the Chair (Chairperson) so that the discussion process can be controlled and the discussion does not evolve into a shouting match.

After the summing up of points the Chairperson should call for a formal vote on the subject on the merit of the points presented.

The points outlined above are those normally employed by debating societies and are a useful framework from which to formulate a debate or discussion in your Group. You may chose to have a less formal structure to your discussions however although it maybe more relaxed you should at all times have the courtesy to listen to peoples points and not let the discussion evolve into a shouting match.

Topics worth consideration fro discussion / debate

Religion / the Church

What are the similarities between Christian churches or between different religions.

Drugs and Alcohol

Pills, smoking, legal and illegal, pressures, escape into your mind, talking to others -can it help? , closing off oneself to society

The influence of mass media on society

What forms your opinions?

Television advertising

The effect of advertising on children / consumers, entertainment versus

Communication, are advertisements fact or fiction.

Employment versus unemployment / school

Green movement

Care of the environment, passing the buck, what are your responsibilities? The ozone hole.

Public liability versus charity

Is helping out and caring for others a thing of the past

The Role of the Elderly in your Community

What will you be doing when you are 55,65,75,85, or even older. Is death a part of living

Pop Culture

Does it have a positive or negative influence on young people.

Experience

Is it something that can be learnt?

Sport

Winning, for love or money (amateur / professional), politics, the Olympics

Modern art

Is it in the eye of the beholder?, is it fraud, class related activity

Starvation

Who's responsible, can we help ? - how? What about in our own country, what should we eat.

Scouting Ideals

Will they be relevant or archaic in the year 2030

Democracy

Rule by the few or the few ruled by the masses (i.e. voting rights), alternatives, rights and responsibilities.

Money

The love of money is the root of all evil, not money itself.

Guilt

Our life-styles compared to those in developing countries, God or conscience (can you separate them?), right or wrong -who says?.

Competition

Is it necessary to develop a competitive nature? - keeping up with the Jones. Are there 20 losers for every winner.

Race

Why isn't the world made up of one race, one colour.

Neighbourhood Watch

Why do we need it? What does it tell us about society?. How important is your neighbourhood to you. What do you owe to society.

Crime

What are suitable disciplinary actions for specific crimes? Who says they are suitable. The cost of crime.

The Meaning of Life

How does God reveal Himself to you? Does He?

The Homeless

Why? , What do they do? How do they live.

What does the future hold

Year 2020. Year 2050, year 2100
Given medical science and technology.
Earth's resources (food, oxygen, water,minerals)

It is possible that none of the above will interest your Venture Unit. Perhaps there is another major issue developing in your community. Base discussion on current topics by basing it on current stories and issues being discussed in news programmes and newspapers. You'll find a wealth of moral, social and political material all around you.

The most important value in discussion and debate is to allow and challenge your Venture Scouts to start thinking and discussing their lives and the world about them.



Build a fun, folding canoe

This fun canoe can be made with two sheets of plywood and basic woodworking skills. It is an ideal project for a Venture Scout Unit.

The canoe is designed to be taken apart for easy transportation and can be erected in about 15 minutes. The canoe is made from 20mm and 12 mm construction grade plywood. It is not necessary to use marine plywood, which is more expensive, but it is a better job. The canoe is held together using cable ties and gutter bolts with wing nuts. The skin of the canoe is a tarp sheet – blue plastic or construction grade plastic. If you want a fancy job then you can make a custom made jacket of heavy grade tarpaulin or canvas. This jacket is put on and kept together using velco or lacing. Feel free to experiment - the original design used nut and bolts to hold it together but cable ties are cheap, quick, and just as effective. The canoe is designed for use in calm waters canals, lakes and quite rivers. The skin is only plastic sheeting and will puncture easily so fast rapids are out. You will also need to be careful of lake and shore bottoms for sharp rocks.

Construction

Start to make the canoe by first making cardboard templates from the drawings and measurement shown above. If you intend to make more than one canoe then this process is a must and will save you a lot of time.

Place the frame templates on the sheet of 20mm plywood and arrange the frames so that there is no waste. Mark out your frames and begin cutting. You will need

You need 5 frames in all

1 of frame No. 3

2 of frames No. 2

2 of frame No. 1

and two frames one for the bow and 1 for the stern

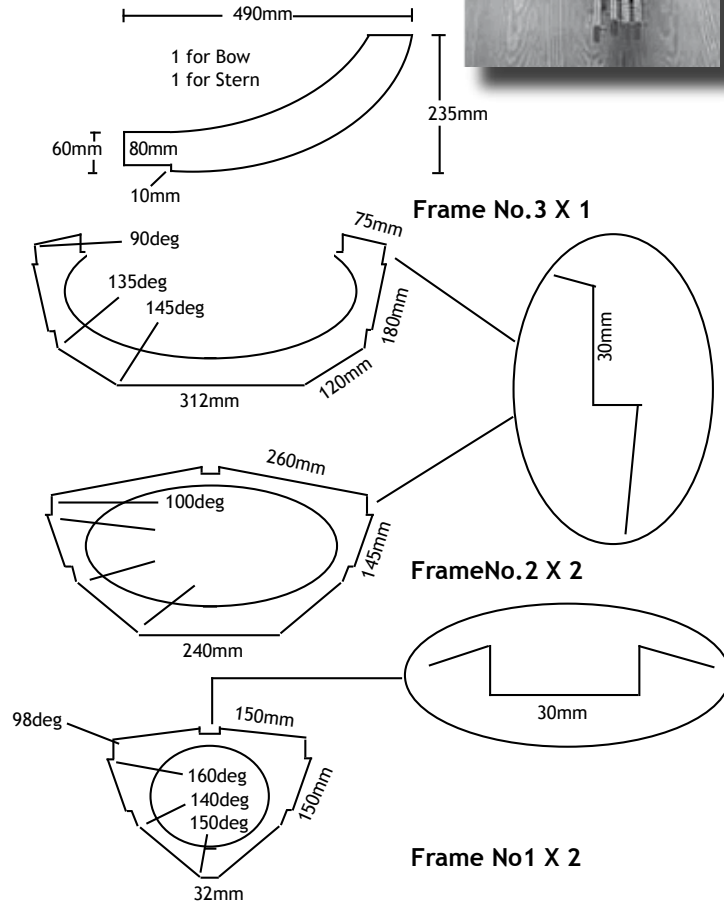

a jigsaw to do this work. Take your time, some parts of the frames are tricky, so be careful. The base board is best drawn directly on the sheet of plywood using measurement provided. Draw the curves by hand joining up the dots, so to speak. If you are planning to build two canoes it is possible to get two bases and stringers from one sheet of ply. The curvy joint is best done by sight. Mark the centre points for the screw holes and draw a line each side of the centre line to give you a limit to the curve. Draw the curve a number of times with a pencil and when you think it looks good cut the base board in half.

The stringers or side-bars are straight cuts. They are best cut with a circular saw and are all 30mm wide.

When all the pieces are cut sand all rough edges. It is also a good idea to paint them with varnish to protect them. Mark up your base board for the frames - the frames are 50cm apart.

Drill holes through the frames and baseboard at the same time so that the holes match. Do the same with the bow and stern pieces. Screw on all the frames into position.

Arrange the stringers (long 1270mm pieces in the middle) and work out their position. Number them so you know where they go. You may have a little

Stringers - sidebars

- 2 No. 900mm (30mm X 12mm)
- 2 No. 940mm (30mm X 12mm)
- 2 No. 800mm (30mm X 12mm)
- 2 No. 840mm (30mm X 12mm)
- 2 No. 1020mm (30mm X 12mm) Cockpit sides
- 4 No. 1270mm (30mm X 12mm) Middle sides
- 2 No. 1050mm (30mm X 12mm) top piece bow and stern to cockpit

trimming to get things right. Drill holes in each end and hold together with cable ties. Position the stringers on the frame and drill through stringers into frame and lock them on with cable ties. Drill holes

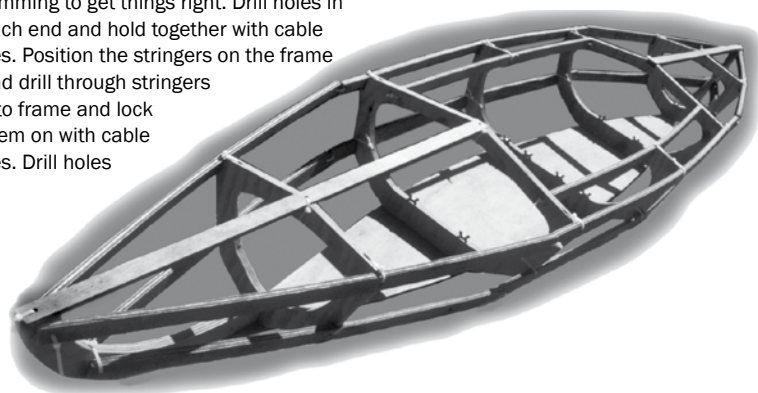

carefully and square through the frames. When all the stringers are on the frames your finished.

Covering the frame is a simple and basic undertaking. Lay out the groundsheet or tarp on the ground. Wrap up the canoe.



Get some packing tape or duct tape and wrap it up like a parcel. With a little more care the tape can become a feature. If you want a better job and have the time you can make a purpose made jacket from canvas or heavy duty tarpaulin. Try the easy way first and get on the water. If you catch the bug then do the jacket version. This will require a bit more skill to cut canvas and sew it together. The canvas then has to be painted to make it waterproof.

Buoyancy

You will need to place some buoyancy device in your canoe to keep it afloat if you overturn. You could simply put a football in each end or you could also make aeroboard pieces the same size as the small frame and place them in the frame as you construct it.

Material list

1no. 8X4 sheet of 20mm construction grade plywood
 1no. 8X4 sheet of 12mm construction grade plywood
 14 no. 75mm 6mm gutter bolts and wing nuts
 Packet of cable ties
 Plastic sheet at least 3 metres X 2metres
 Tools as required.

Buoyancy device.

You will also need a paddle and a life jacket.

Base boards

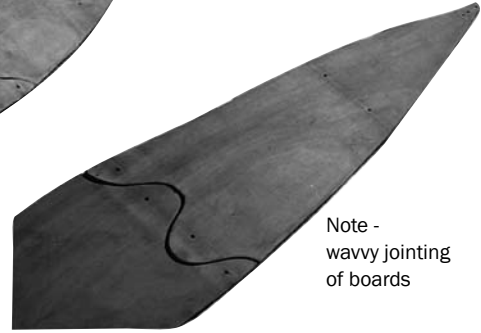
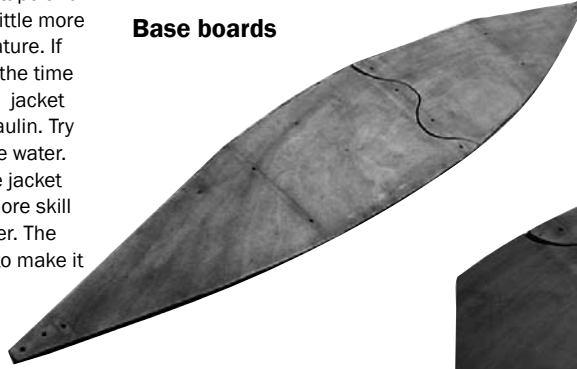

Note - wavy jointing of boards

Base board is held together using centre frame of canoe body using long gutter bolts and wingnuts

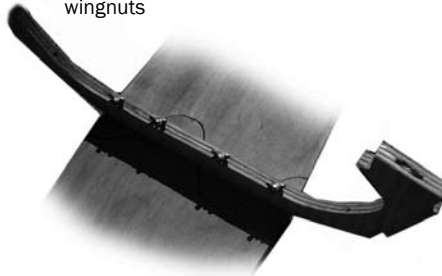

Detail showing fixing of bow and stern frames

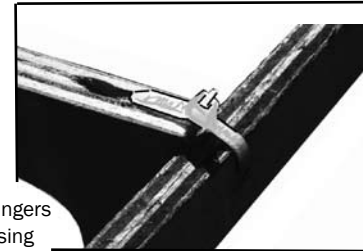

Frames and stringers held together using cable ties

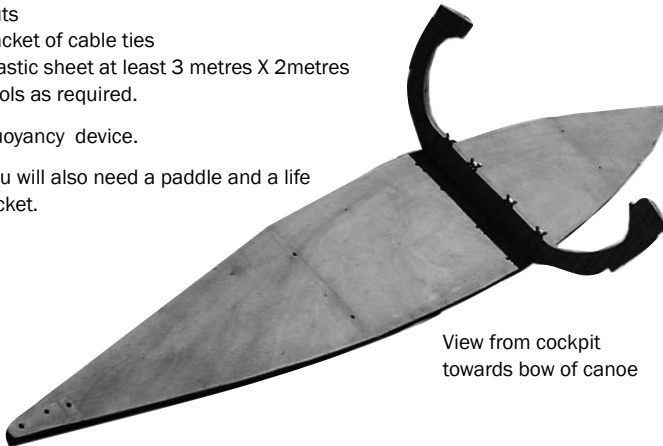

View from cockpit towards bow of canoe



Camp Games

Kubb

Kubb is a Swedish throwing game reputed to have been played by Vikings who played with the bones of their defeated enemies.

The object of the game is to knock down your opponents' 'kubbs' using short batons. Once all the opposing 'kubbs' have been knocked down you can then attempt to knock down the 'King' and win the game.

You need a play area 5 mts X 8 mts; a 'King' which is set up in the centre of the play area. You also need 10 'kubbs' - 5 for each team and 6 throwing batons and corner sticks to define the play area. Teams can have up to six players.

Team A start by throwing their batons underarm, end over end (no sideways helicopter throws are allowed) attempting

to knock down as many 'kubbs' as they can.

Before Team B can start they must throw all 'fallen' 'kubbs' into team A half of the play area - between the 'King' and their baseline.

Team A then stand up those Kubbs - now called Field Kubbs - where they landed.

Team B must knock down these Field Kubbs before they can go for the baseline Kubbs. It's fine if a baton knocks down more than one Kubb. But any baseline Kubbs accidentally knocked over before the Field Kubbs are toppled should be set upright again, unless the last Field Kubb has gone down with that very throw.

Team A must now throw any fallen Kubbs back to their opponents' half. If there are any Field

Kubbs still standing on their side of the pitch, however, they can stand level with the furthest one when throwing their batons.

Turns continue until one team has knocked down all their opponents' Kubbs. The players must then retreat to the baseline and use the rest of their turn to try to knock down the King and win the game. (The King can only be toppled in the very first round if two batons are left, a pretty unlikely event.)

The joy of Kubb is that players' fortunes wax and wane. One moment you're sure you're about to lose, the next you're on top again. Sometimes games are over very quickly, other times they last longer. It's one of those games that doesn't really make sense until you play it - and then it's hard to stop.

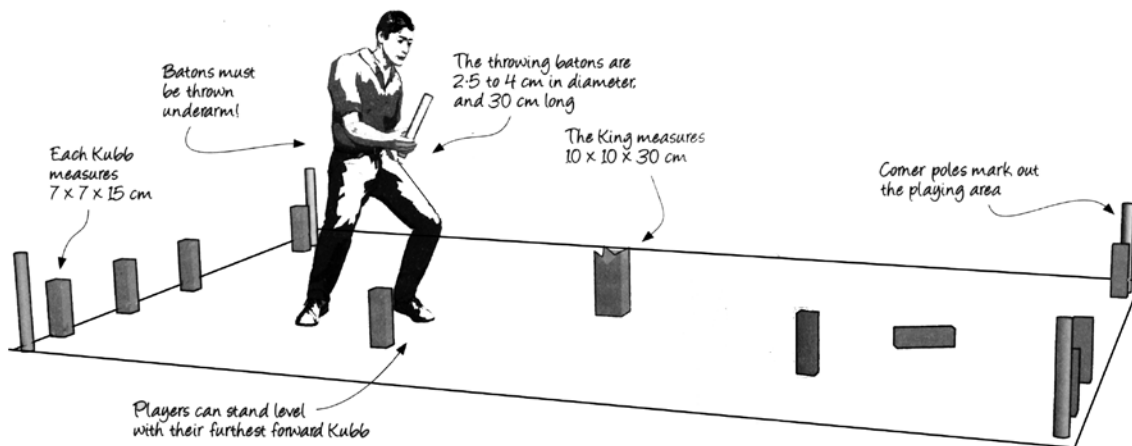

Ladder Golf

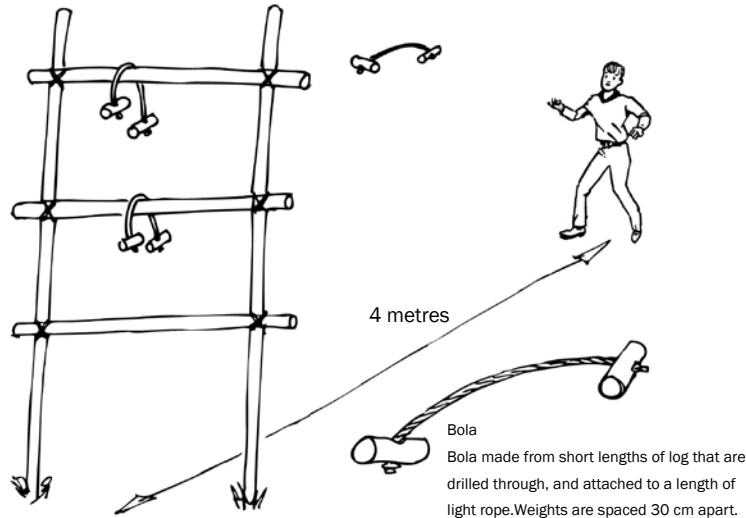

Ladder Golf is played with 2 or more players or teams. Each player has 3 bolas. A bola is 2 'small logs' or weights attached by a light rope. The object of the game is to wrap your bolas around the steps of the ladder. The ladder consists of 3 steps, a top, middle and a bottom step.

Playing the Game

Prior to the game play a line must be set 5 metres from the ladder. This is called the toss line.

Ladder Golf is played in rounds, each round consists of all players tossing 3 bolas. The first player must toss all 3 bolas before the next player is able to toss his or her bolas. Bolas can be tossed in anyway the player chooses, as long as they are tossed individually and can be bounced off the ground. The winner of the round

earns the first toss in the next round.

Games are played to an exact point total of 21. In order to win, a player must be the only one to score exactly 21 points after the completion of a round.

If a player goes over the exact point total, that player's points for that round do not count.

For example: A player with 18 points needs 3 points to get the exact score of 21 in order to win. If that player has 5 points hanging on the ladder after all the players have tossed all strands, none of those points count and the player will enter the next round with 18 points again needing 3 points to win.

In the case of a tie, the players that tie will play as many overtime rounds as needed until one player ends a complete round

2 points ahead of the other player. The 2 point rule only applies in overtime rounds. During regular play any player can win as long as that player is the only one to score an exact total of 21 points at the end of that round no matter how many points the other players have.

Scoring

After all teams have tossed all their bolas, scoring is determined by the bolas that are still hanging from the steps. Players can knock-off bolas during the course of the game, in fact knocking-off other players' bolas is encouraged and a good way to play defensively. Bolas that are knocked off during play do not count as points. Only bolas that are left hanging after all bolas are tossed are counted as points.

Points

Points are determined by which step your bola wraps around. The top step is worth 3 points, the middle step is worth 2 points, and the bottom step is only worth 1 point. Players can score an optional bonus of 1 point by hanging all 3 bolas from the same step or by hanging a bola on all 3 (1-2-3) steps in one round. The highest amount of points available per player is 10. This is accomplished by hanging all 3 bolas on the top (3 point) step.

Team Play

With multiple ladders 2 players on opposite teams would be on one side and the other 2 opposing players would be at the other game ladder. One side would toss all bolas and the other team would toss them back. Same rules apply.

Duel

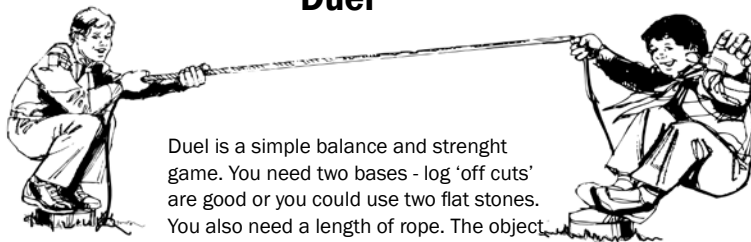

Duel is a simple balance and strength game. You need two bases - log 'off cuts' are good or you could use two flat stones. You also need a length of rope. The object of the game is to pull your opponent off their 'island'.

Frisbee

A Frisbee is a great camp toy and endless game variations are possible. Below we list some of the more popular variations.

Bottle Guts

12 players; 6 discs; 12 cones

Bottle Guts involves two teams of six facing each other in a line, with each player having a cone in front of them (the bottle). Give each team three discs. The object is to knock over the opposition's bottles. Players must throw from behind their bottle, and may only throw when their bottle is upright. Each player starts with three lives. Each time a player's bottle is knocked over, they lose a life. When they have no lives left, they are out of the game and must sit down.

Frisbee Rounders (Frisbee Baseball)

18 players (2 teams of 9); 1 disc; 7 cones

Set up a diamond, similar to baseball. There is no pitcher, otherwise the fielding positions are similar. The "batter" simply throws the disc from homebase, and must

re-throw if it is a foul or doesn't travel at least 5m. Three fouls mean the batter is out. The batter is also out if their throw is caught on the full. Runners are out if the disc reaches the base they are running towards before they do. Only the fielders on a base (the basemen) may run with the disc; everyone else must throw it to a baseman. The batting team gets a run each time a runner reaches home base, when they get 3 outs the teams switch roles.

Five Hundred

6 players; 1 disc

Two groups of three are separated by a distance of about 20m. One group throws a high disc above the other group. If someone catches it, that person scores 100 points. That group then throws another high, floaty throw back and they get a chance to score points. The winner is the first person to score 500 points. The game is non-contact; no pushing or holding is allowed. This game is very good for practising positioning, jumping and reading the flight of the disc

Frisbee Soccer

12 players (2 teams of 6); 1 disc; 8 cones

In frisbee soccer, you are not allowed to run with the disc, but the disc is allowed to touch the ground, or roll along the ground. Once the disc is on the ground, either team may pick it up, but maintain the non-contact rules, so once a player has picked it up, their marker must retire 1m away. If two players pick up the disc simultaneously, then the offence retains possession.

The game can be played on a soccer or football field, or a similar field set out with cones.

Score by throwing the disc through the goalmouth.

Modify the number of players to suit the field size.



Keepings Off

8 players (2 teams of 4); 1 disc; 4 cones

Form a 20m square with the 4 cones. The aim of the game is to retain possession of the disc by passing it to teammates for as long as possible. Players may not run with the disc and have a stall count of 10.

Art is fun

In your Unit there will be some Venture Scouts who are quite artistic and others who are equally convinced that not only are they 'no good at all at art,' but that art plays no part in their lives. This attitude is a great pity, because we are surrounded by different aspects of art throughout the whole of our lives and the ability to appreciate it adds greatly to the pleasure of living.

The prime reasons for having art as part of a programme could be:

To develop in the Venture Unit an awareness of the importance of art in all its forms, making life richer, more interesting and worthwhile.

To give them confidence in their own ability to produce artistic and beautiful things.

To awaken latent talent which could perhaps lead to a career or an interesting hobby.

To create an awareness of design and beauty.

The method of achieving these aims should be by encouraging the Venture Scouts to explore and experiment in all forms of his/her choosing, with guidance on occasions from experts,

A simple way of introducing the subject to a Venture Scout Unit might be to run an evening called 'Art can be Fun' (or something similar). Have available on tables around the room as many different materials as possible, including both traditional and unusual media. The following might be included as a start: clay, terra cotta, plaster of paris, plasticine, expanded polystyrene, pieces of cardboard,

plywood, paper, newspaper, polymer colours, soft galvanised wire, pieces of broken coloured glass, metallic spray paints in cans (gold, silver, etc.), canvas, sacking, hessian, pieces of fabric of all sorts and colours, firewood, garden canes, cardboard tubes, crayons, charcoal, glues, scissors, blow lamp, old screwdrivers, tin sheet, old cans, soldering iron, tools of all types including pliers, wirecutters, silver foil, old tins of paint and all manner of apparently useless bric-a-brac . . . you can add your own ideas.

Encourage the Venture Scouts to forget all traditional teaching and experiment with



any of the media they choose, to produce something which they feel is beautiful, pleasing or stimulating in some way. Above all encourage freedom of expression and a sense of abandon which gets rid of normal inhibitions and timidity on the part of the person who thinks they are not artistic. The results, to say the least, should be interesting. It is amazing how a simple session like this can stimulate a potential interest among a number of Venture Scouts in the Unit.

Aeroboard

This is available in large block form as the packing cases for business machines, copies, etc. and any business house can probably help. It can also be purchased in blocks as buoyancy from boat shops but is then inclined to be expensive.

The material is carved with a hacksaw blade. Encourage the production of large three-dimensional patterns and shapes and even primitive sculptural sculptural forms. The material is so easy to use that it creates great freedom of expression. It can be coloured with traditional water colours.

Candles

Making large (or indeed small) candles is an art form which almost anyone can enjoy, and it can be a very profitable

form, too. Either obtain wax from a craft shop or melt down cheap white candles.

Clay and Terra Cotta

These materials offer a whole range of special techniques and many books are available. Sculpture is particularly satisfying as the desired shape can be built up piece by piece and alterations made at any stage. Try also pottery — slab pots made of flat pieces of clay joined together, and pots moulded around thick cardboard tubes. Try decorating slabs of clay or terra cotta with pieces of broken coloured glass. Then get these fired in a kiln so that the glass runs and fuses into the most wonderful patterns. A local school, or the potter will be able to help you in the use of a kiln.

Try building a potter's wheel and making traditional pottery. Find out about glazes and slips and decoration. Examine early pottery at your local museum and try to discover why they made the pots the way they did.

Drawing from nature

(i) Take a sketch pad into the country, or even onto your own front doorstep if you live in a town, and try to sketch what you see — a bird, a plant, a twig, the front gate — really look at it. Look at its form, the way it moves. Try to capture the atmosphere of what you see rather than producing just a photographic likeness. Think how its muscles work, how its bones fit together and let these influence your drawing.

If expert help is now needed, and the local art class or group is the place to get it. Also many books are available from your local library, or bookseller. Practice! Practice!

Carving and Sculpture

Sculptures can be carved from any material, from soap to stone and wood. Experiment and find a media that is to your liking and suits your pocket. Whittling is a nice way to introduce carving. Get a penknife and a stick and away you go.

Relationship of design to living

Consider: how art many form influences your life, its surroundings, the atmosphere you move in, your home, your clothes, the things you buy. Try to find out what you like and dislike about the design and atmosphere of these things. Try to find out what common factors make for the things you like or dislike.

Get an Architect or Town Planner to talk to you about what goes into making a beautiful building, room or town, and see if your own conclusions agree with the points he makes.



Projects to try

- Prepare a colour scheme for a room of your choice (your own room? or your Unit H.Q..?). Think about the atmosphere you want to create, the uses of the room, the practical nature of your scheme.
- Design a new piece of furniture directly related to the human body, such as a chair. Firstly, look at some chairs which you feel are well-designed, then measure them. Measure a human being and see how his measurements relate to the comfort or lack of it in the chair you have measured. Then set to work design your own piece. Think carefully about the right materials for the job.

» Examine some CD cover or dust jackets of books. See which one you like most and ask yourself why. Have a competition to design a cover for one of these.

Other aspects

If one of these catches your imagination, find out more about it for yourself: glass etching, marquetry, scraper board, paper sculpture, action painting, textile design and printing, lino cutting, screen printing, wallpaper design, town planning, interior design, etching, flower preserving, burning shapes in timber baulks with a blow lamp (the soft fibres burn away leaving the hard ones) . . . and so on.

Mouse Trap Cars

Making mouse trap cars is a fun activity for your Venture Unit to enjoy which will develop their creative and craft skills. The cars can take many shapes and forms depending on design. Propulsion is achieved by using the inherent energy contained within the spring mechanism of the mouse trap.

What do you need

You will need a range of lightweight building materials such as cardboard, light wire, CDs to use as wheels, dowel and pieces of light wood. A mouse trap for each car.

The idea

The idea is to harness the energy in the spring mechanism to provide a driving force for your 'car'. This is done by transferring the force to the axle of your vehicle. A string is attached to the spring mechanism and placed around the axle. When the trap is released the spring

moves forward and as a result causes the axle to move thus propelling the car forward. The secret is to maximise the force in the spring, perhaps by adding a pole to the spring mechanism which will multiply the force available to move your car. There is also the question of reducing the 'drag' or friction factor of your car by using a lightweight slim design.

Below are pictured a number of designs

Fixing the string to the axel

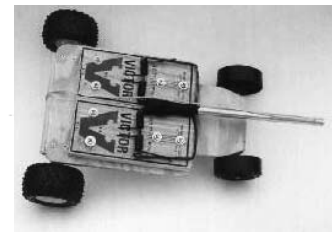
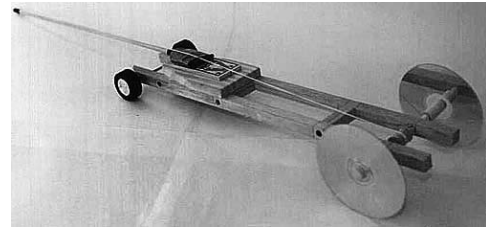
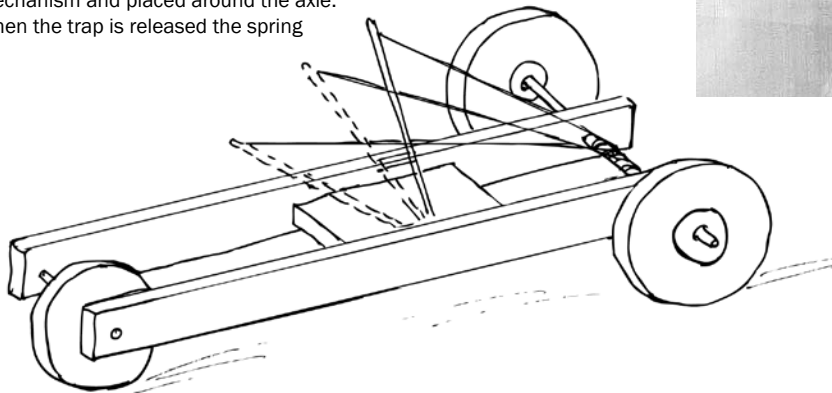
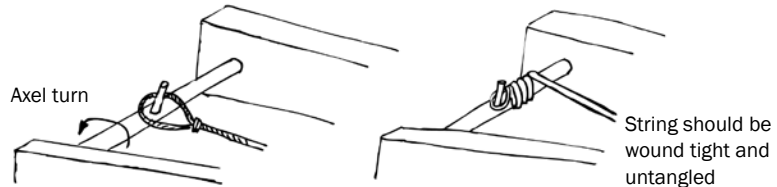

and details of the mechanism. The idea of mouse trap cars is experimentation and creativity. Explain the how to and leave the rest to them. You will of course need equipment and some basic tools to ensure their dreams become a reality.

Testing

When all the cars are build then it off to the test circuit - a large hall. Set up a test track and run an number of events - longest distance travelled, best design, fastest start etc.

Cardboard Ovens

Bring camp cooking to a new level by making and using cardboard box ovens. They are very simple to make and are surprisingly effect as an oven. In fact they operate at the same rate as your home cooker oven.

The oven is constructed with a standard bankers box (storage box). Line the inside of the box with tin foil - you can do this by using double sided tape. Carry the tinfoil out over the edge of the box and fix down on the outside as shown.

Next you need 4 empty drinks tins and a basic baking tray about A4 paper size (30cm X21cm). Available in most supermarkets.

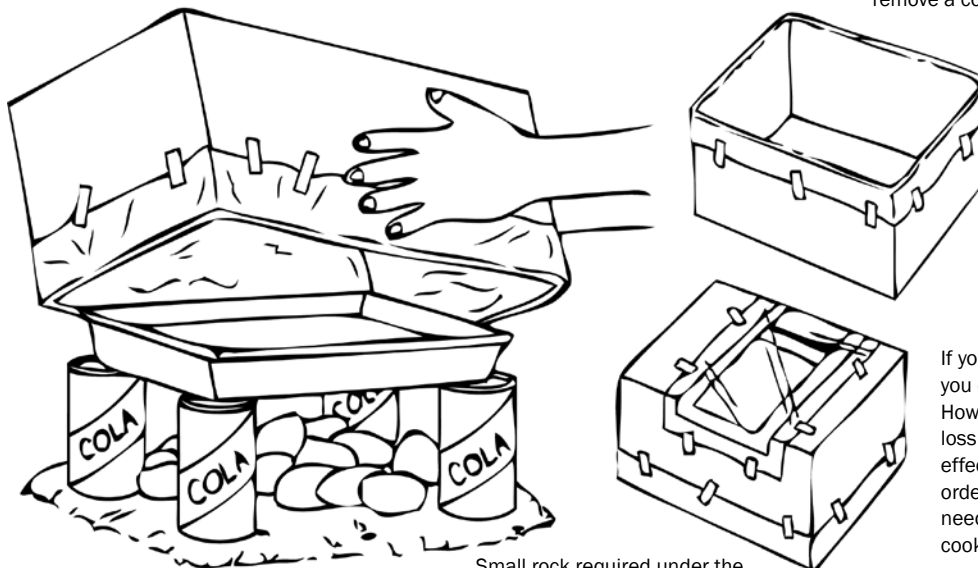

Small rock required under the edge of box to allow airflow

Clear a piece of waste ground and create a 'tower' using the 4 tins and baking tray as shown. Charcoal is placed under the 'tower' and the box placed completely over it. A small rock is placed on one edge of the box to allow some air to get in - otherwise the coals will go out.

Charcoal

The charcoal should be heated away from the oven in a separate fire area. When the coals are hot they are lifted - using a trowel or camp spade to the oven.

One charcoal briquette, when hot, delivers approx. 20 degrees of heat. So normally you will need about 10 coals to cook most of the common recipes.

These guidelines are just 'rules of thumb'. Charcoals come in many different sizes so you might need to experiment to see what is the best time to allow. The 20 degree of heat per coal relates to the hard compress charcoal briquette. You can also get wood ember type charcoal and this burns a little cooler.

Make some scones

Buy a pack of scone mix from a supermarket - mix as instructed and you should be able to make about 6 - 8 scones which will fit on the tray. Normally, they will take about 16 -18 minutes to cook. Certainly check them after 15 mins.. and see how they are doing. Use this exercise to calculate the heat inside the oven for other recipes. If it is too hot remove a coal or too cool add a coal

If you want a 'fancy' design you can add a window. However, there will be heat loss in this area and it may effect heat and timings. In order to make a window you need to use plastic from a cooking bag

Travelling Light

When backpacking, and in particular lightweight backpacking, there are a number of objectives you should have in mind. Weight is usually at the top of the list; you want everything as light as possible. Equipment that is light and functional. Cost; you have to be able to afford it.

These three criteria form what could be termed the eternal triangle of backpacking.

Most lightweight gear comes marked with a weight, but manufacturers being manufacturers, these are not always as accurate as they might be. It is easy to become confused or misled. The easiest answer is to shop for your kit armed with a spring balance. A balance that is graded up to 7kilos is easily enough to read and determine the weight of items.

Tents and Shelters

A good tent that is both strong and light can be expensive. To get a structurally strong flexible-pole tent you have to go up-market to the geodesic designs and that costs a lot of money. Most manufacturers offer a number of tents in the lightweight range. If you are travelling alone the lightest will be in the range of 1.5 kilos however if you are traveling with others the weight of a two or three person tent can be distributed with approximately the same weight carried as a solo tent. For the ultimate adventure you should not dismiss the humble bivouac sheet or, to use the army parlance, the basha sheet. This six foot by eight foot piece

of PU nylon has tags around the outside so that it can be pegged down or you might consider a plastic sheet. It is the most versatile, lightweight, inexpensive, and durable shelter available. It's use is limited only by the ingenuity and expertise of the user and if you don't have any, money it can be an interesting possibility. If you intend travelling over mountainous terrain, perhaps camping high up then you need a tent that will perform in extreme conditions and that will be expensive. No matter what method you choose you will have to make compromises along the way, floor space, weight, strength. The tent you select will probably, have, a super thin groundsheet to save weight so you will also have to have a sleeping mat both to protect the groundsheet and insulate your body from the ground.

Sleeping

Without a shadow of a doubt the best you can sleep in is a down bag but if it gets wet it is next to useless. If your bag is likely to get wet, steer clear of down. The alternative is a man-made fibre bag.

These come in many guises but the principle is the same in all. A long, man-made fibre is hollow and thus traps air. As with down it is the trapped air that keeps you warm. The advantages of artificial fibres are clear. The bags are cheaper than down, they are warmer underneath you (because they are harder to compress), they keep you warmer when wet, and they are easier to keep clean.

Disadvantages? They are substantially heavier and bulkier than down, and won't last you anywhere near as long. The compromise is clear. If you can stay out of the wet and can afford to pay more, invest in down which lasts longer, so costing the same in the long run. If you constantly get

wet when camping, buy a man-made fibre bag. Another alternative is to consider a fleece inner bag and combine it in use with a lighter sleeping bag depending on expected weather. The bag is very good for those who bivouac and can be used to effect with a good down inner bag. Handle or better still borrow one to try before you buy. Zips should all be well baffled to prevent loss of heat. If the bag you choose is a man-made fibre one, check to see if it comes with a compression stuff sack. If it doesn't and you want one, this will add a few euros to the final price.

Rucksacks

With rucksacks two things are important from the outset; size and waterproofing. You have available to you any size of sack you want, and (whatever the manufacturer may say to the contrary) none of them are waterproof. The capacity of a rucksack is measured 'in litres. A small day pack weighs in at about 25 litres. From there you have various sizes up to a general all round rucksack sized at 75 litres. With one of these you will be able to manage anything up to mountaineering (at a push), but you pay a price for the facility. Having 75 litres to play with you feel a terrible urge to fill up all the space, even for summer camping in the lowlands. Because of this, some people prefer a 65 or even a 50 litre rucksack. After those important criteria the rest more or less comes down to personal preference. If you are organised in the way you pack, a one section rucksack is simpler and more effective. It is an advantage if your pockets can be detached, but having them fixed saves a bit of weight. Some harnesses leave more room for air to circulate between you and the sack. In the end it is down to personal choice and budget, consult the brochures and cross

check with people you know who have bought rucksacks and see what they recommend.

Cooking and Eating

You will need a stove, something to cook in, something to eat out of, something to eat with and (very importantly) something to carry water in. The essential part of the 'something to eat with' is a general purpose blade. This will cut up anything you want to eat to manageable portions as well as whittle. Save the weight by cutting down on the number of utensils you take rather than by using flimsy 'camping' ones which bend the first time you use them.

When you choose a billy make sure of two things. Firstly, it should have a good handle, preferably one that will not get too hot to hold whilst cooking is in progress. Secondly, it must have a close-fitting lid. There are many styles of billy available to choose from. The two pint 'paint tin' type, is a handy size and can be used on a wood fire. The rectangular army type that hold up to a litre is an excellent choice. These fit nicely into the side pocket of a rucksack and can be filled with snack foods and

brew kit for the day's use.

Stoves

The array of stove available is down to choice. The choice here is between solid fuel, liquid or gas. Solid fuel comes in blocks that resemble large white tablets. A packet fits neatly into the metal tray that you burn them in. This stove is little bigger than a pack of playing cards. The system is foolproof since you merely set a match to the blocks and add more for extra heat, take away for less heat. Moving on to liquid stoves your choice increases considerably. Most simple of all is the meths. burner. Here you have a container into which you pour meths. and then set fire to it. The most popular, the Tranzia has a windshield built round the container which also neatly holds the billy. Again the design is foolproof. The stove is heavy and bulky so watch the weight.

Still in the liquid fuel range, there are the pressurised burners, running on either paraffin or petrol. The paraffin stove traditionally known as the primus stove has undergone some major design upgrades in recent years and a new collection of multi-fuel stoves are now

available that allow different fuels to be used by the same stove. Once burning, these stove provide an intense and efficient heat source and can be adjusted to give various rates of heat. Gas stoves are simple to use. They are relatively cheap to buy but are expensive to run. Unless used in a sheltered area they are useless as the heat is quickly blown away and as the canister runs down so does the pressure.

Once again, compromise is the final solution. You will generally find that pressurised paraffin is the tried and trusted stove for most formal expeditions, and is the general favourite of many. Solid fuel is a useful last resort to have available when you are travelling light, relying in the main on wood fires, and there is no way of lighting one. Gas fuel is simply a consumer convenience stove that is simple to use in all but extreme conditions.

With so much wonderful equipment around it is easy to get carried away and seek for the best in everything. A large rucksack to carry a five season down bag with a Goretex bivi-bag, a super stove and a geodesic dome tent. In reality, if you think over the use to which your equipment will be put carefully you will often find that the best is not suitable for you and you are just as well off with something cheaper. Then, when your style of travelling or camping does demand the best, the expense becomes worthwhile.



Low Level Rope Courses

Low level rope and obstacle course are great fun to use and build. There are an excellent tool for developing teambuilding skills. The obstacles illustrated give you some idea of what can be built. Some of our campsites and commercial adventure centres offer the use of such courses as part of their programme, and this is the preferred way that this activity should be undertaken.

Like all courses of this kind safety guidelines have to be observed. This is done via a tutor or leader who works with the group on each exercise. The team work together and ensure the safety of the

participants on each obstacle.

Some basic rules to keep in mind:-

Safety equipment is worn and used correctly at each obstacle.

No one is forced to complete an obstacle. If a person feels unsafe or secure then they are free to step back.

When assisting a team member through obstacles - feet first is the preferred method of lifting and 'passing through' a person. The persons head should always be above a persons feet.

Approach each obstacle with care. Listen to instructions, devise a plan of overcoming the obstacle, move slowly and safely through the obstacle. Evaluate how you undertook the obstacle and learn by the experience.

No messing of any kind should be tolerated on obstacles.

Traditional, however, such courses have been the preserve of Scouting and using these obstacle we have been able to build teams, teach leadership and group management skills.



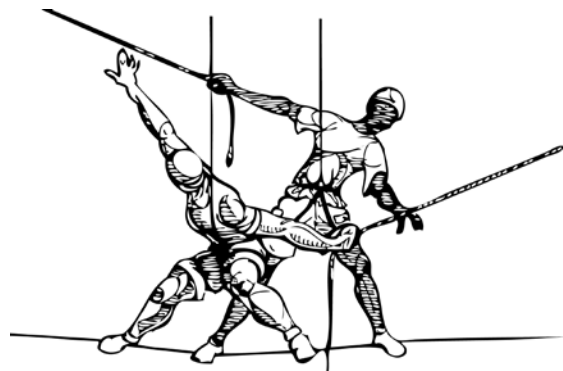
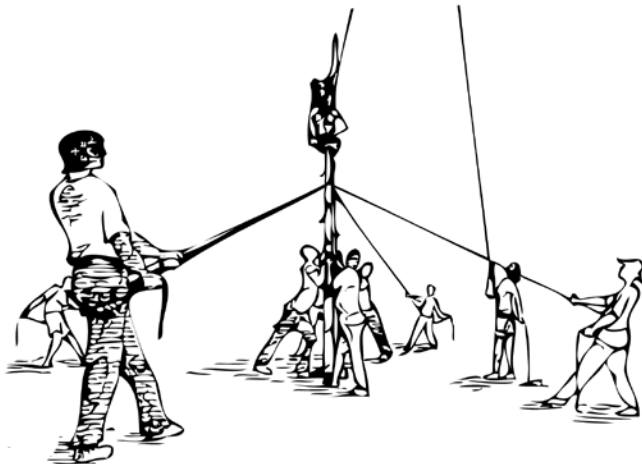

Whizz Planes

A fun game for a winters night.

Mr. Whizz, an aircraft manufacturer is sub contracting some of their vast aircraft construction work to a new of select manufacturers. Your team are a sub contacting business seeking a contact.

The competition for selection as a sub-contractor involves the building of 4 aircraft. These aircraft must be ready for viewing and inspection at the test site in the allotted time .

In order to win a contract your aircraft must be capable of covering the set test distance and meet all design specifications.

You will be supplied with enough material for 8 aircraft, 4 must be displayed. Extra material provided for pretesting and design modifications and tweaks.

Only your best aircraft should be brought to the test site.

Only one aircraft of each type will be allowed to compete.

All aircraft must be marked for identification.

The test circuit is available for pre-testing your craft before the official test time.

Illustrated here are 4 planes designs from 'Advanced Paper Aircraft Construction by Campbell Morris' ISBN 0 207 15455 4. Buy it for your Unit at www.amazon.com for more design ideas

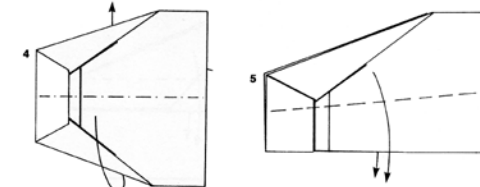
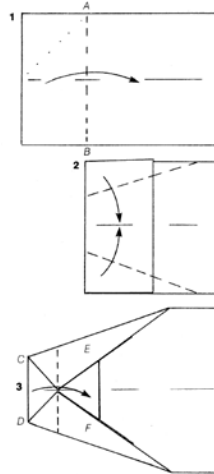

Simple Glider design

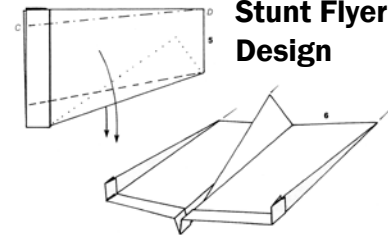
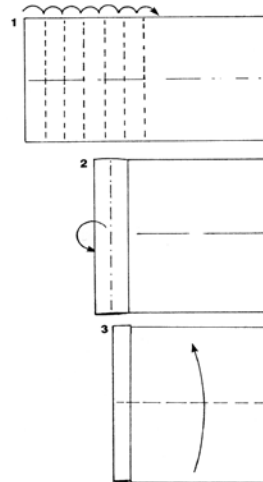
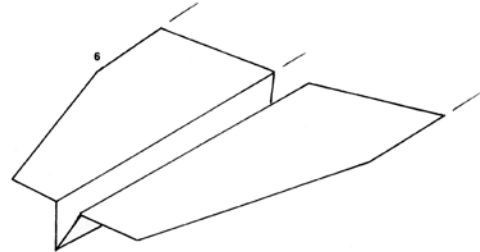

Stunt Flyer Design

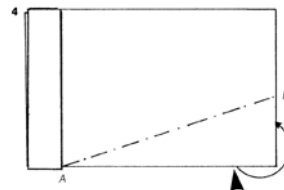

Leader instructions

A test site is provided - a long table in the middle of the hall.

Each team is given 8 sheets of A4 paper

Establish an official throwing line

Competition

Best flyer - in a straight line

Best landing on the test strip

Best stun flyer

Longest flight time

Best identification marking

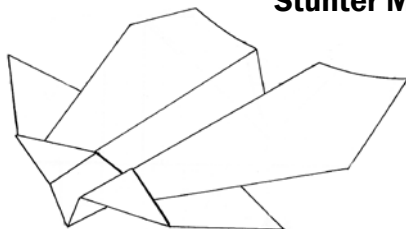
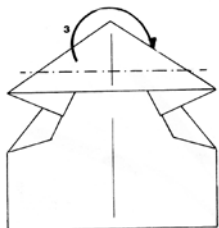
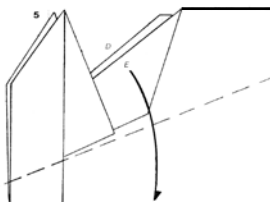
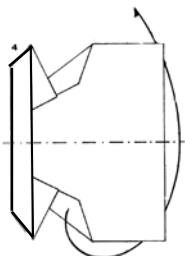
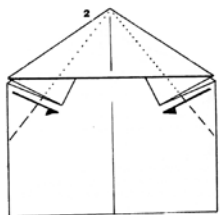
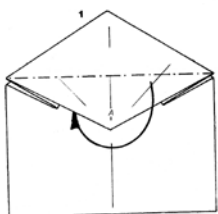

Stunter Mark II

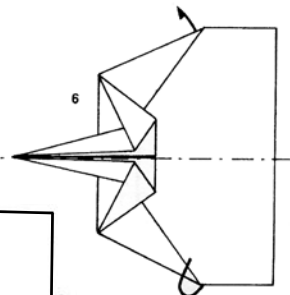
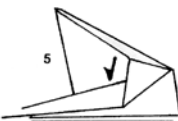
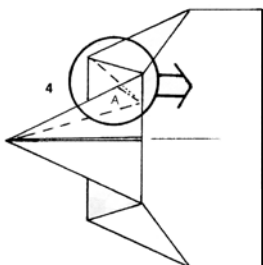
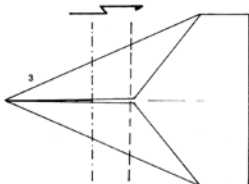
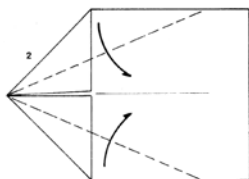
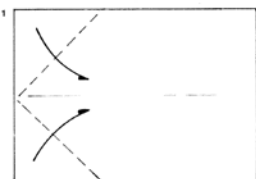

Long distance dart

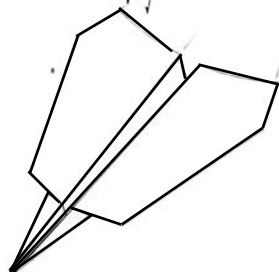
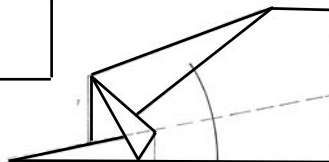

Specialisation

Specialisation - what are your Unit good at? Are you or could you be experts in a particular subject or skill?.

Venture Scout Units are ideal teams to specialise in a particular area of Scouting. These specialities can then become vehicles to the passing on of that skill to other sections at County, Provincial, or National events.

Lets look at an example

Say your Unit decide that they want to specialise as a re-enactment group - Vikings. The Unit will become experts on everything 'Viking' - clothes, crafts, weapons, warfare. The Unit then go about the process of becoming experts. They make authentic costumes, weapons and crafts. they learn how Vikings lived, traded goods etc.

This will take time to achieve and the material can be gathered over a period of time by individuals as well as group efforts. Then you are ready to work with others.

The County Cub Day - your Venture Scout Unit set up and man a Viking base. Cubs can come along learn about Vikings, Have a mock battle, make some Viking money etc. This is a professional presentation not a 'mickey mouse' base because your Unit have put the effort in and are now experts in this area. Likewise on the same event we can have a Venture Scout Unit organising and running brilliant widegames and treasure hunts with interactive actors. Or another Unit running a base on power kites and kite flying.

The possibilities are as wide and varied as the imagination of your Unit.

The consideration of specialisation should not be approached in a half hearted way, it needs commitment and the creation of a high quality activity.

The aim of this process is primarily - fun for the participants, learning and discovery, and service to Scouting.

Young people from the other sections will love the bases and adventures you create and will want to get involved too.

You can of course specialise in straight forward Scout skills such as large scale pioneering, orienteering, climbing and mountain skills without the need to 'dress up' in costumes. There is a place for all types of specialisation. Scouting has a need for all types of fun activities and programme bases that allow young people to explore and learn in a fun filled way.

Programme

Your specialisation subject can now form part of your programme - perhaps one meeting a month can be set aside for creating items, learning new skills, or fine tuning presentations. As you become experts you will be fielding offers from Country, Provincial and national programme teams to help them out and run your base at an event - at an agreed cost to cover expenses of course!

Some areas fo specialisation to consider

- Blacksmithing
- Outdoor cooking
- Pioneering
- Climbing
- Archery
- Survival and backwoods skills
- Canoeing
- Sailing
- Whittling
- Knotting
- MPC/Sionnach
- Orienteering
- Nature and woodcraft
- Samba band

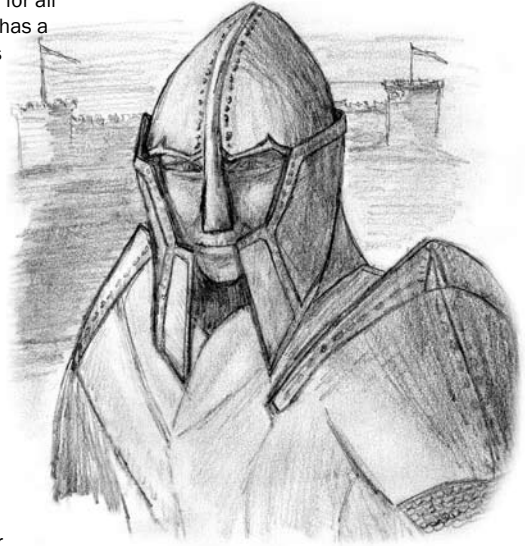

Historic re - enactment

- Crafts
- Film making
- Photography
- Knifemaking
- Wavin pipe band
- Kites and kite flying
- Power kiting
- Hovercrafts
- Scrappers - (scrap heap challenge)
- Eco campaigners
- Service crew
- Dance
- Re-enactment group - Celts, Romans, Vikings,
- Primitive tools
- Caving/ropework
- High and low rope courses
- Arts
- Teambuilding exercises
- Wide games
- Treasure hunts
- Wood lathing
- Woggle making
- Tent Platform building
- Mad Scientists
- Street theatre
- Mouse trap car events
- Rope making
- Star watching



Team Building games

Ropework skills

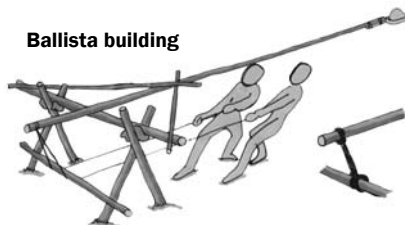

Ballista building

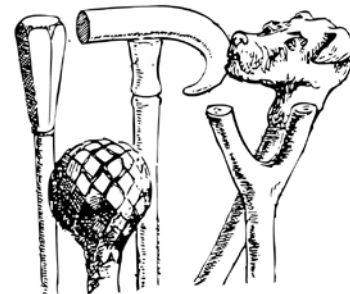

Whittling

Mountain Skills

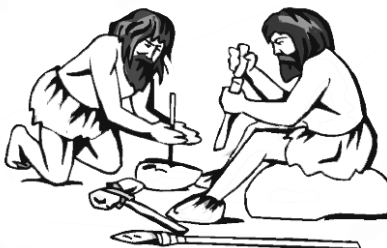

Stone age and primitive skills

Archery

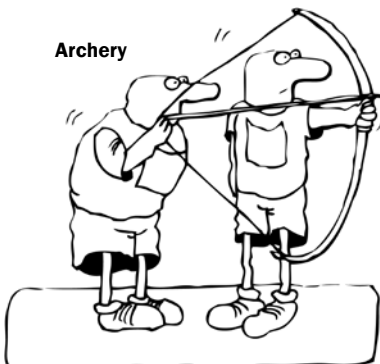

Wide games

