

MAKE & DO
SKILLS

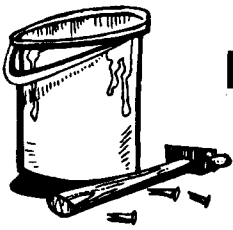



Handicrafts satisfies a young persons need to make and create things. It permits full expression to creative feelings and provides another means of self - expression.

Making things can be one of the most absorbing activities for Cub Scouts and Beavers and allows the young person to fine tune both their creative and construction skills. If the finished article is interesting and useful it will probably be used to destruction. In our use of handicrafts it is important that we steer clear of those handicrafts clearly connected with school. We have in this booklet tried to present a number of handicraft ideas which are linked to the scout programme, rather than a comprehensive collection of handicrafts. Such crafts as plaster casting which we can link with tracking and trailing or electric buzzers which can be linked to Morse code.

Crafts should be of interest to your section age group. They should be linked to programme items rather than be just crafts in themselves. Making musical instruments so that the Colony or Pack can present a musical item in the Unit Gangshow or at a parents night. Encourage parents and other experts to get involved it is not the Leaders role to be an expert at everything merely the channel for or finder of experts. Many Leaders fail to see the real purpose and value of handicrafts, seeing it only as a programme filler, an occupier of time. They fail to use it as a creative outlet, a form of expression, as well as a chance to master the skills involved. It is an important part of the complete learning process of all children. Physical development and mental growth are by - products of a handicraft programme.

One of the pleasures of life is to be able to make something and to see it evolve under one's hands. Young people like to see results so in the initial stages choose a model that can be finished quickly. Models which work, however simple are ideal. When preparing a project work on broad outlines rather than finicky detail. A simply picture of the finished project will provide an initial incentive to most young people. Don't be too disappointed if the finished result is a bit messy, point out the rough edges and encourage them to be more accurate. Remember, this is a learning by doing process rather than a competition, plenty of help is needed as well as encouragement - an opportunity to involve parents perhaps?

It is important to encourage the natural creative urge of young people. Unless you do, the urge may disappear and be replaced by a lack of confidence. Learning by doing is important to everyone. You should recognise that much work at this stage in a young persons life will be of a primitive nature. Don't look for or expect perfection. Use praise and encouragement generously. Start simply and rely on encouraging the young person to make a good job and promote parent involvement to continue the interest in a handicraft. The enthusiasm you show for his/her efforts will be rewarded if he/she is shown how to handle tools and work materials - perhaps a job for Cub Scout and Beaver Scout fathers.

Remember - Growth is not determined by how good a job a young person does but how much he/she has progressed from where he/she was.

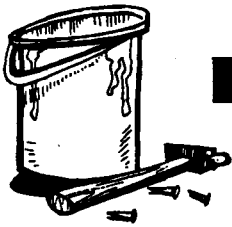

Boomerang

This is a perfect model for indoor use and is especially fun for young people to use, thus learning the practicalities of throwing and catching a boomerang. In its one thickness form it is ideal for indoor use, however if you combine two thicknesses together with some small coins you can create an excellent outdoor boomerang. First tape a coin to the centre of each tip of one boomerang, then lay another on top to sandwich the coins. Tape the two boomerangs together.

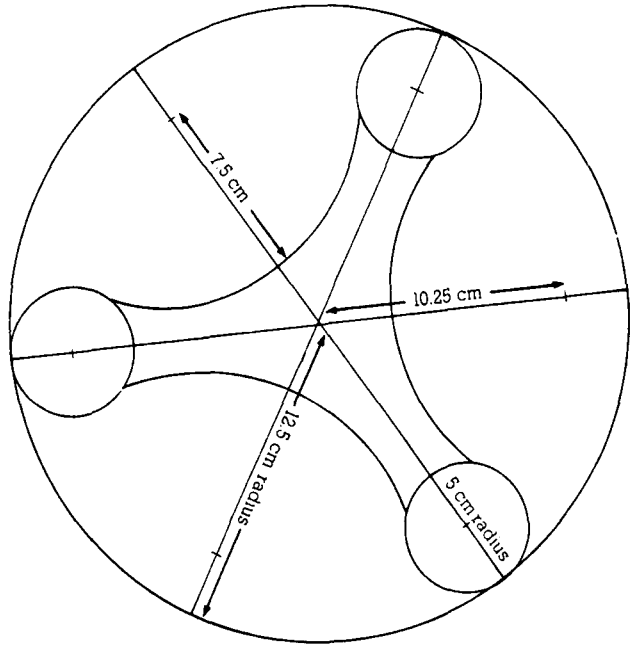

Cardboard three-blader.

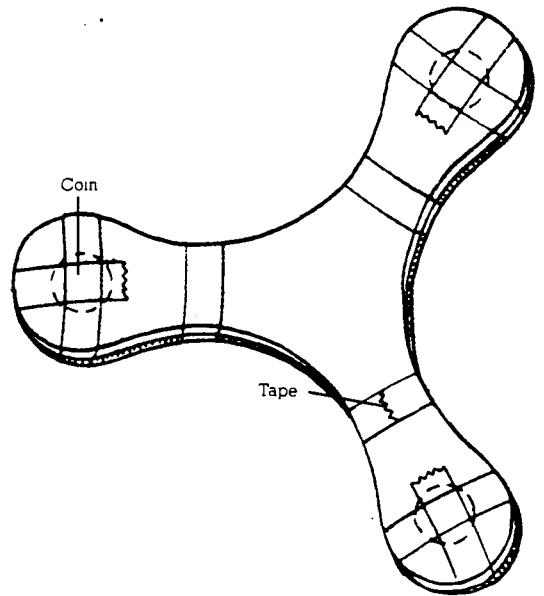
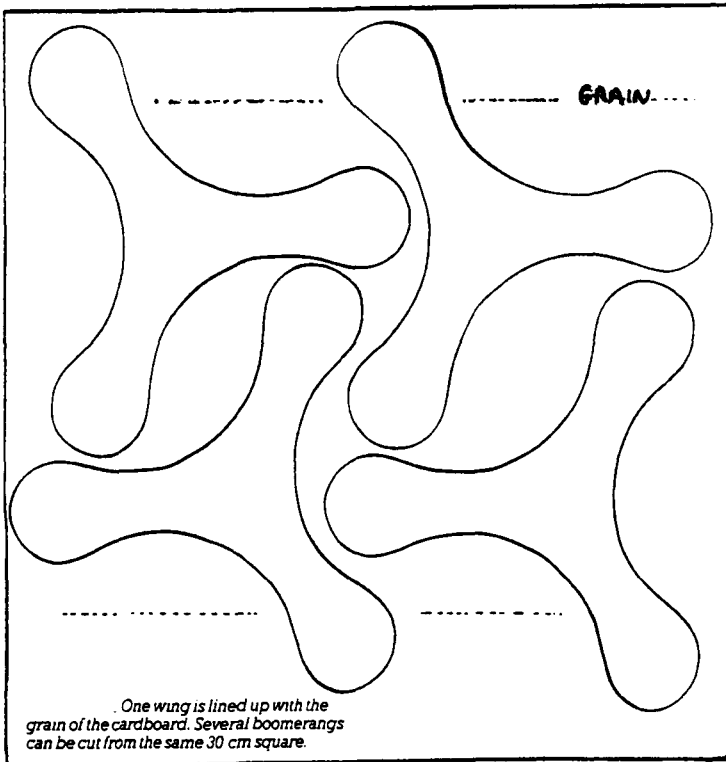

Cardboard combination boomerang. (Thickness not to scale.)

Throwing the boomerang

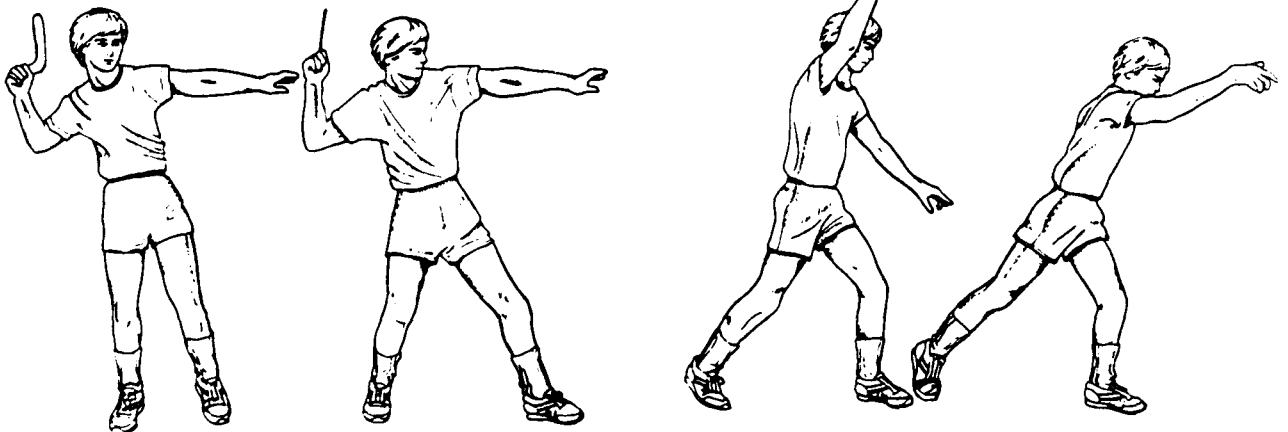

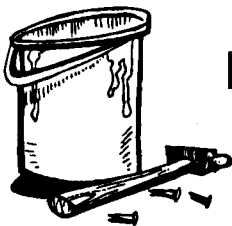

Printing

Printing in its simplest form is applying colour to one surface and transferring it to another. A wide range of techniques can be enjoyed by Beavers and Cub Scouts / Macaoimh. They can make greeting cards, letterheads, book marks, prints for framing. Printing does not require elaborate equipment.

Flat card printing

Cut shapes out of thin card. Glue the shapes together on to a base board. Ink the raised cut out shapes. Place a clean sheet of paper on the inked surface and press firmly. Carefully remove the paper and the first part of the print will appear in the picture. Gradually build up the surface of the paper with several shapes of different colours.

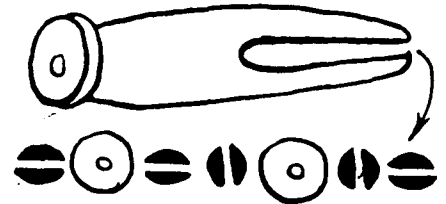

Felt printing

Cut design from felt. Glue felt design to a block and print from this. the felt will absorb the paint and act as a block.

String printing

Cover a wood or cardboard block with glue and press string design down. Paint the string and print. If a repeat design is desired, glue the design around a tin can, then roll across the paper.

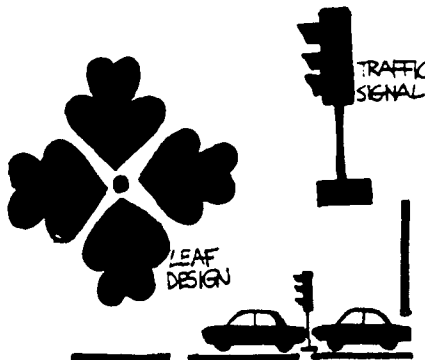

Spatter prints

Spattering over a cut - out pattern or stencil is also effective, or place an object on the printed surface and spatter over it. The object when removed will then leave its shape.

The spattering is created by using an old toothbrush. There are two methods of applying the paint. First dip the toothbrush in paint. Next draw the toothbrush across a piece of stiff cardboard. This action will produce spatter. You could also rub the toothbrush over a piece of wire mesh screening or an old shive. Different effects can be achieved by altering the height of the spatter action from the paper.

Straight line prints

Cut strips of card in various lengths. Ink on one side. Build up a picture on paper of straight lines in various lengths and colours.

Block printing

The blocks are created by cutting or carving slots and designs in a wood block. Again the same method is applied whereby ink is applied to the block and the block pressed onto the paper.



Potato Block printing

Potatoes make good printing prints, if used straight away. They are easily carved, but last one or two days. One potato makes at least two designs.

Sponge printing

Sponges can also be used. The sponges can be shaped with a craft knife. The sponge is then dabbed in paint and the design placed on paper.

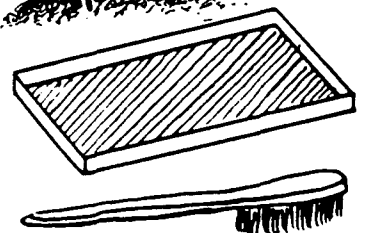
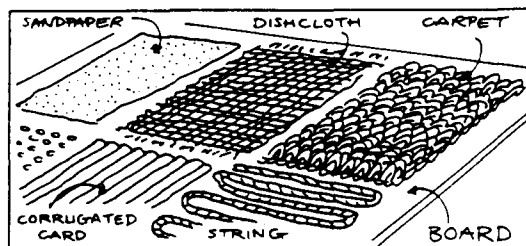

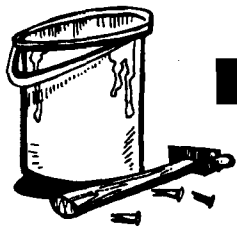

Paper craft

Paper is cheap, available and versatile. Using paper as a creative medium, many activities are possible

Paper copter

Rule a piece of paper into squares of 2cm and copy the plan onto the squares. Cut it out and fold it as shown, and its ready to fly. It will spiral to the ground like a helicopter. Stand on a chair, hold the copter high and let it fall.

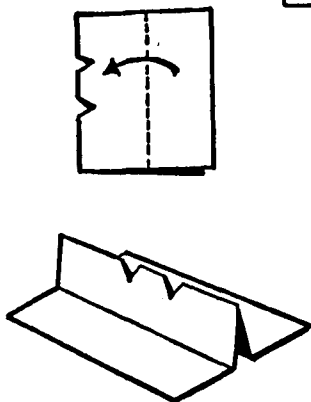
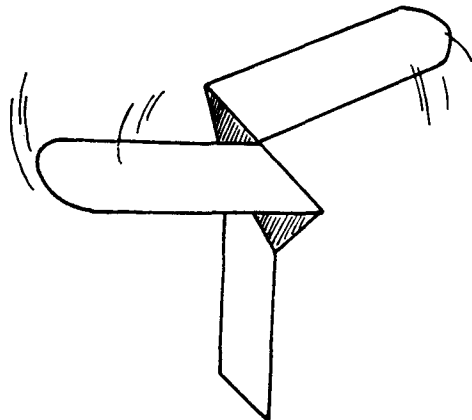
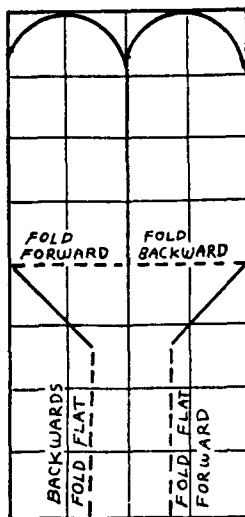

Totem Poles

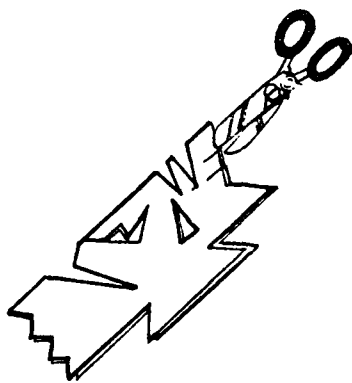

Paper whistle

Cut a strip of paper about 20cm long and 4cm wide. Now fold it in the middle and fold the ends outwards. Cut a small 'V' shaped piece out of the middle. Hold it tightly to the lips and blow.

Paper cup

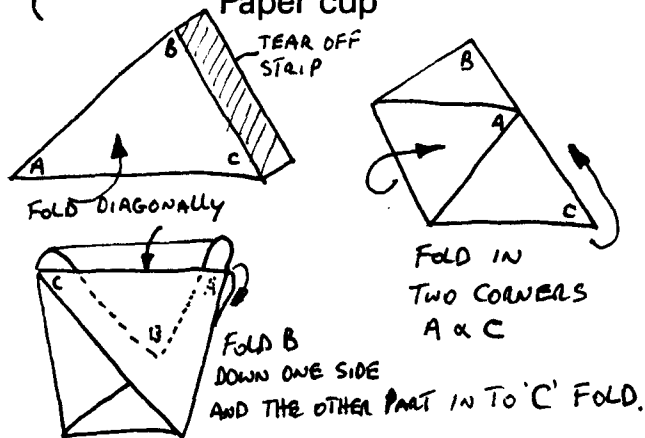

Wolf

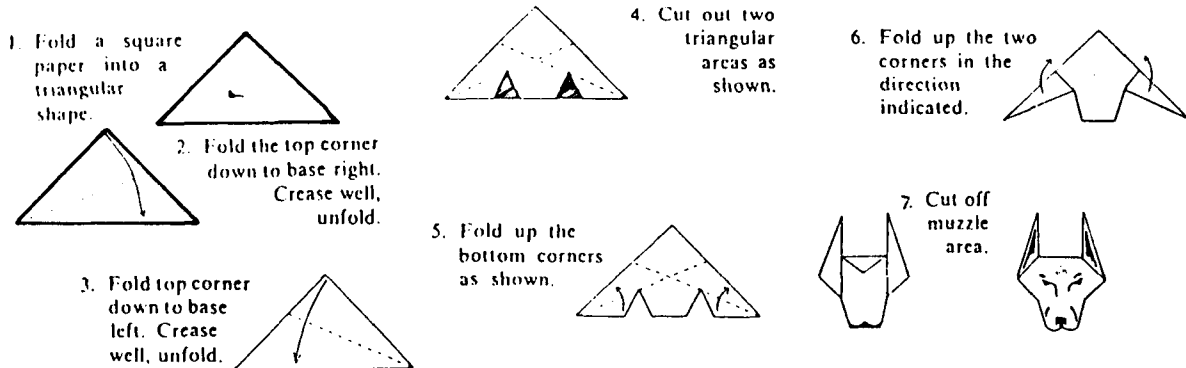

Windmill

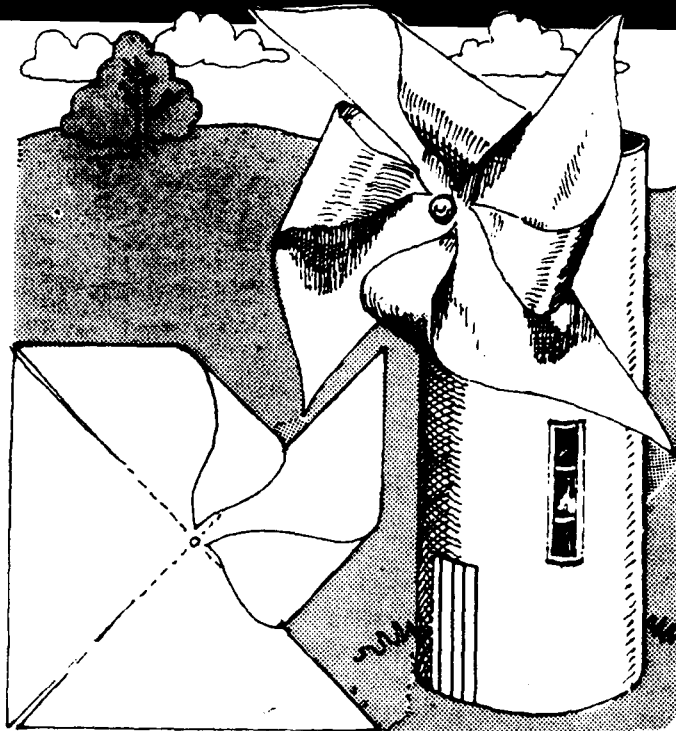
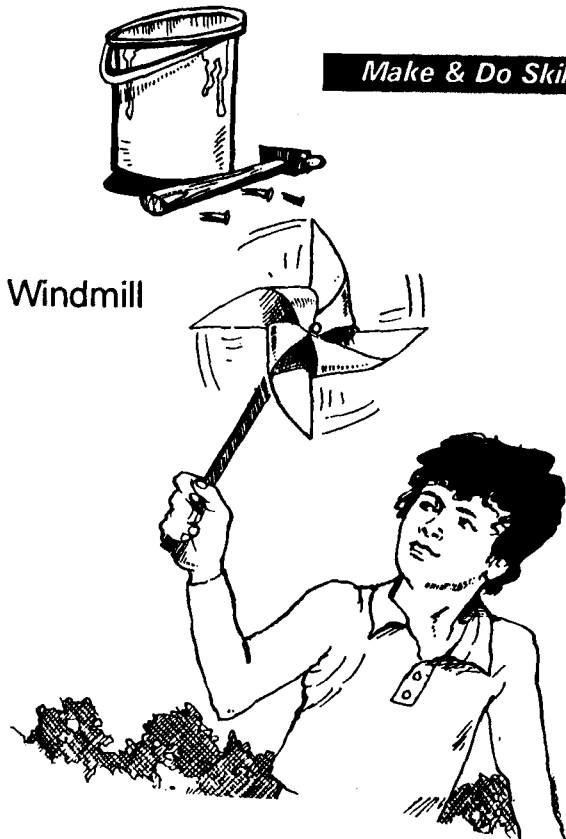

1. Fold paper in half diagonally.

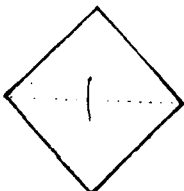

2. Fold down the top corner from a point about a third of the way down.

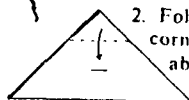

3. From the centre of the base, fold up one of the bottom corners.



4. Fold up the other corner.



5. Turn paper over.



6. Decorate.



Peace lantern



1. A square piece of paper

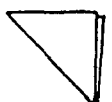

2. Fold the paper diagonally



3. Open the paper



4. Turn the paper so that the folding becomes convex



5. Fold up the paper



6. Open the paper



7. Fold the paper sideways

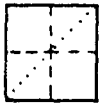

8. Open the paper



9. Fold the other diagonal

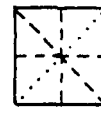

10. Open the paper

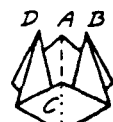

11. Fold corners B and C together.

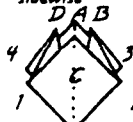

12. ... in such a way that A and C come towards each other

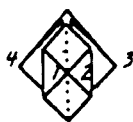

13. Fold flaps 1 and 2 forwards towards the centre



14. Fold flaps 3 and 4 backwards towards the centre



15. Stick a piece of tape across the flaps



16. Decorate the sides

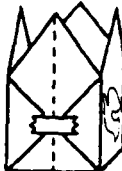

17. Open the lantern and fold out the upper flaps



18. Cut a piece of cardboard to fit the bottom of the lantern. Fix a wide candle on to the piece of cardboard



19. Place the candle in the lantern and light the candle. The lantern will float for several hours



20. To simplify lighting the candle, make a matchholder from a piece of stiff wire

Cat

1. Fold paper in half diagonally.

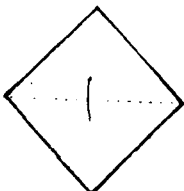

3. From the centre of the base, fold up one of the bottom corners.



4. Fold up the other corner.



5. Turn paper over.



6. Decorate.



Dog

1. Fold paper in half diagonally.

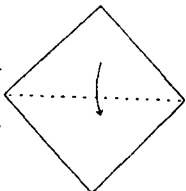

2. Fold down side corners as shown.

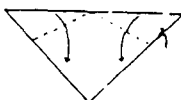

3. Fold back the top and bottom

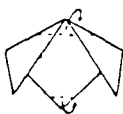

4. Decorate.



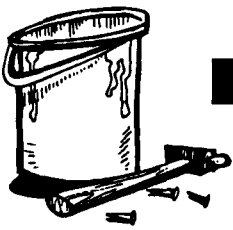

Paper Planes

Most young people can make a paper plane which in effect is probably a paper dart rather than a true paper glider. There are numerous other designs rather than the simple paper dart, each with its own unique characteristic. Some are built to glide other have stunt capabilities others are long distance machines. Apart from the paper folding skills such an exercise can develop there are also the understanding of aerodynamics. When the planes have been built you can hold a contest to discover the plane that can do - the longest flight, the best stunts or the best landing.



Throwing skills

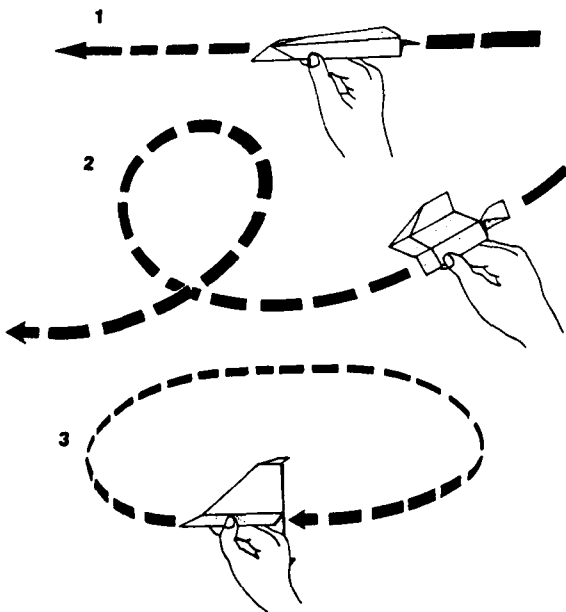

Stingray Glider

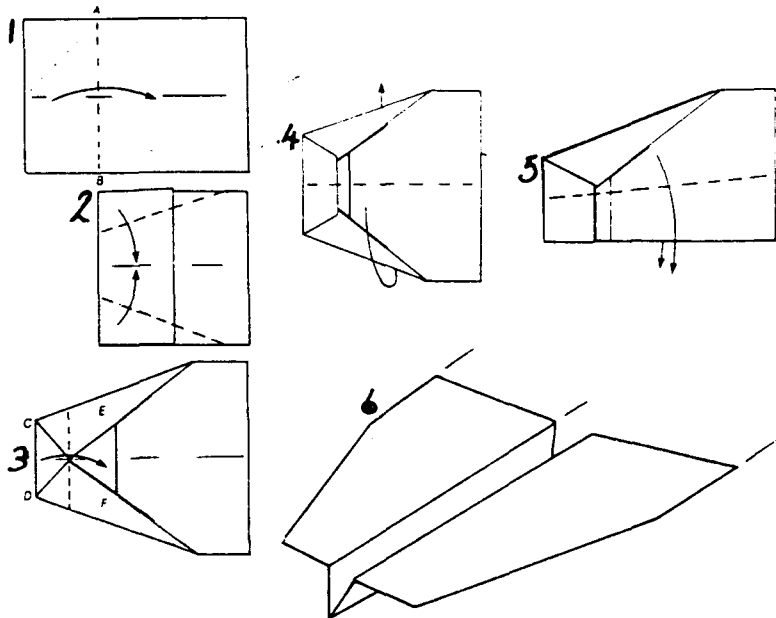

Dart Fighter

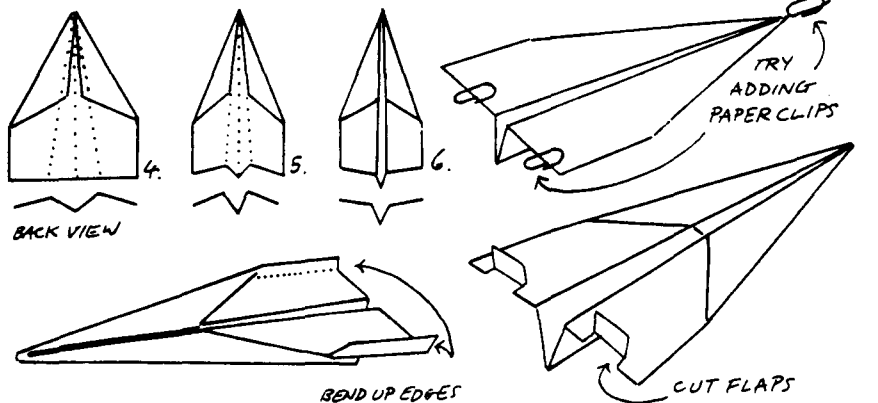

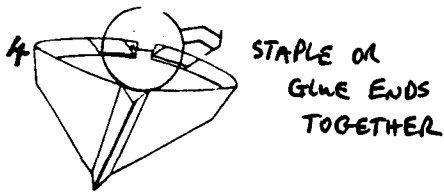
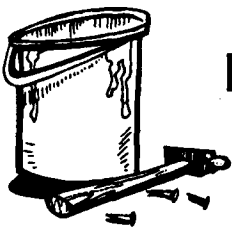

Space fighter

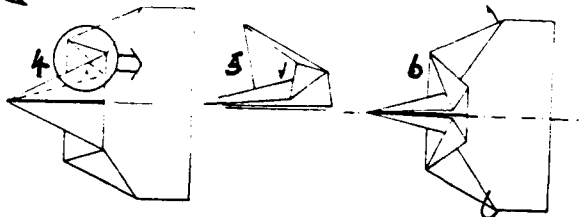
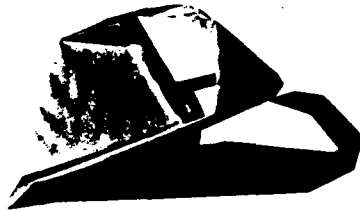
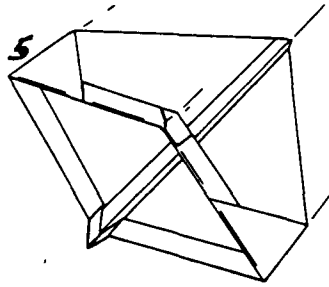
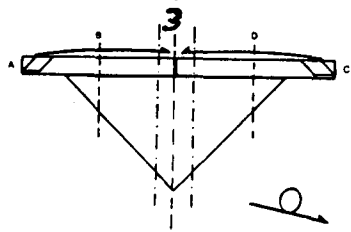
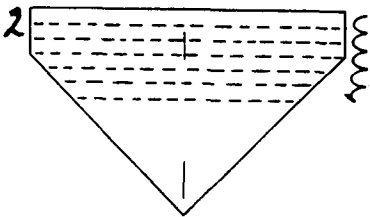
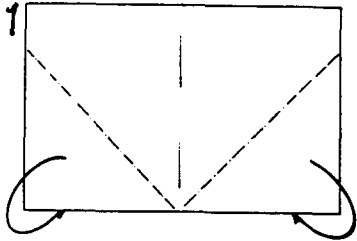

The Swooper

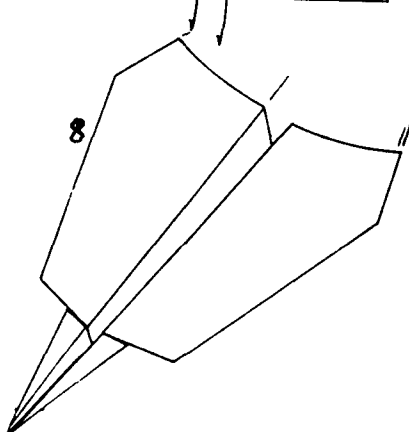
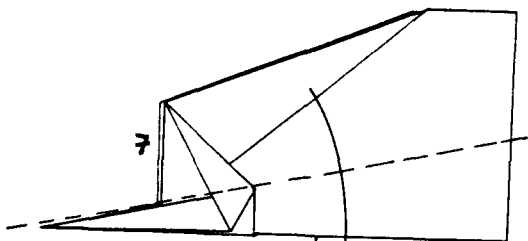
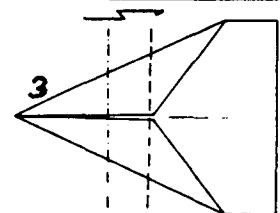
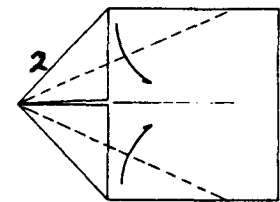
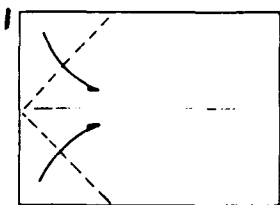

The flyer

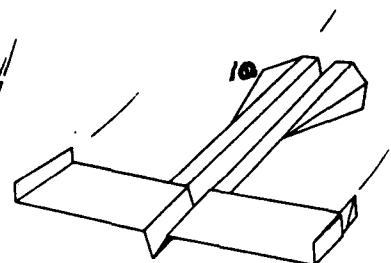
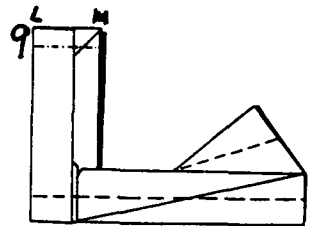
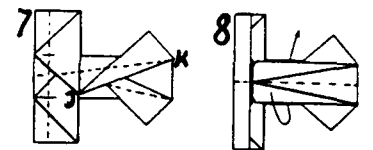
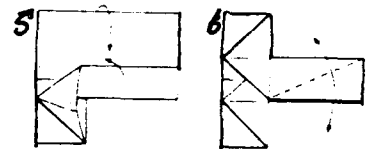
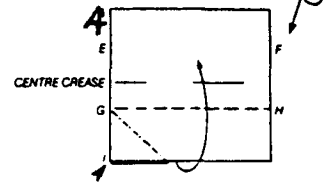
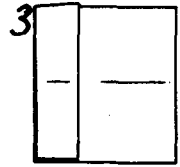
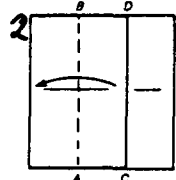
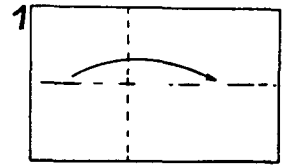

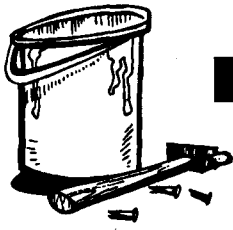

Electromagnet

In order to make an electromagnet you need a number of items a battery, large nail, pins and long thin plastic covered wire.

Wind the wire about fifty times in the same direction around the nail - leave at least 10cm of wire not wound at each end. Connect the ends of the wire to the terminals of the battery, and now move the nail over a small pile of pins.

The nail attracts the pins like a magnet. If the wire is disconnected from the battery the pins will fall as the nail ceases to be magnetised.

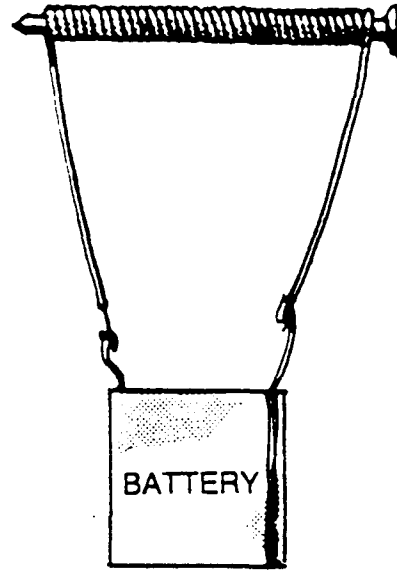

Breakdancer

Now that you have an electromagnet try making a breakdancer as shown

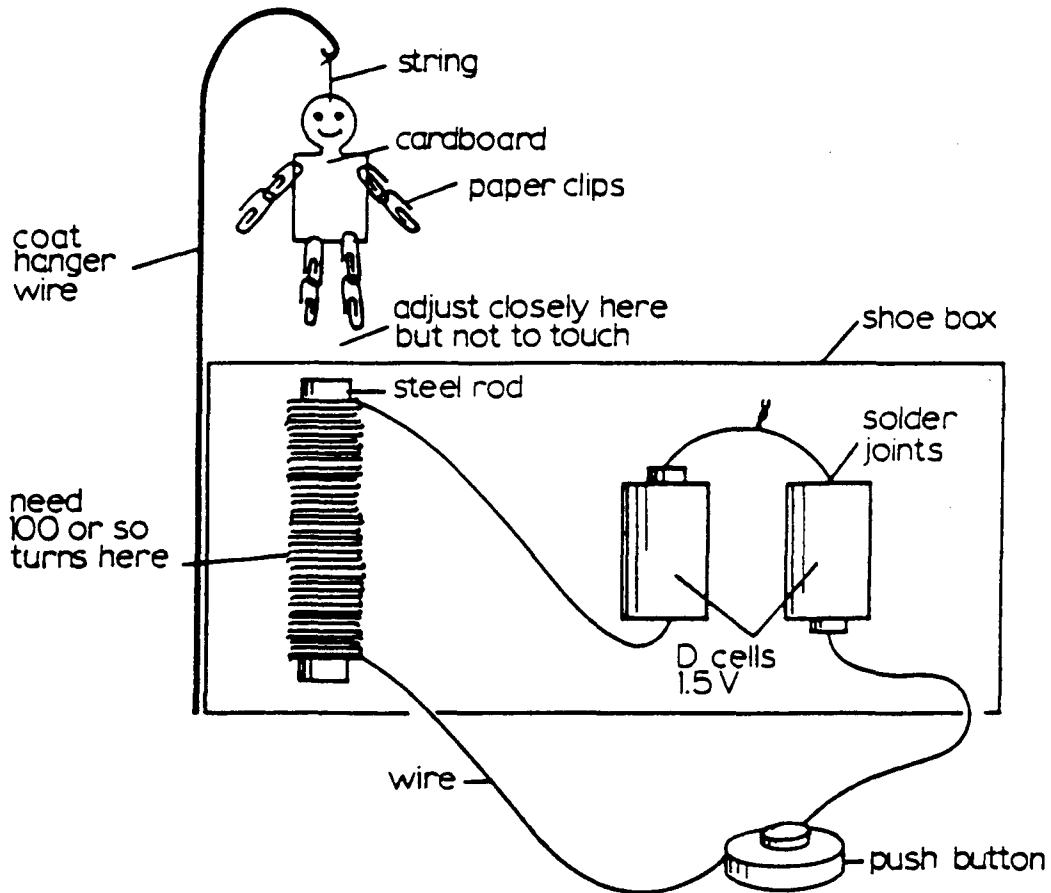

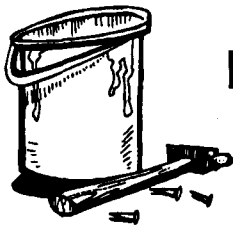

Electric Car

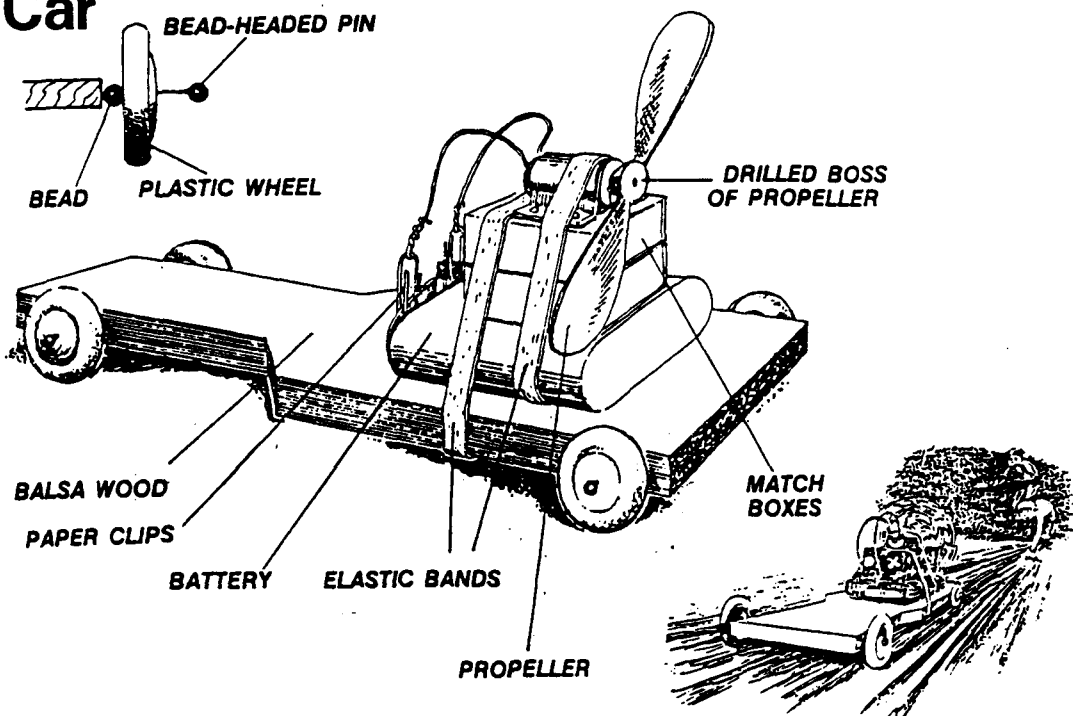

Truth Machine

A truth machine is easy to make and can be used as a training aid within the Pack or Colony to teach or test various subjects. When the answer is correct the circuit is complete and the light goes on.

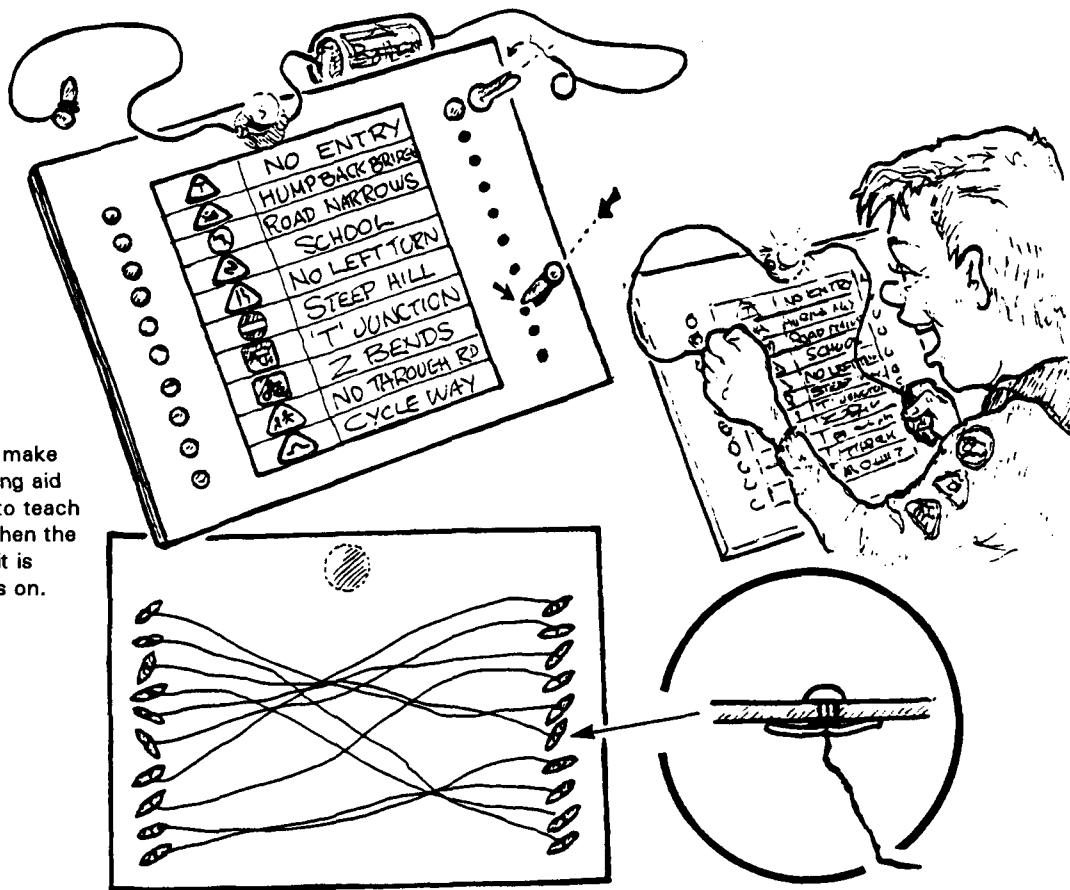

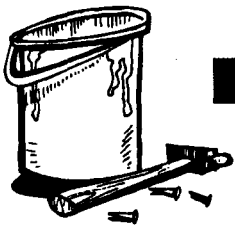

Morse Buzzer / Nerve Tester

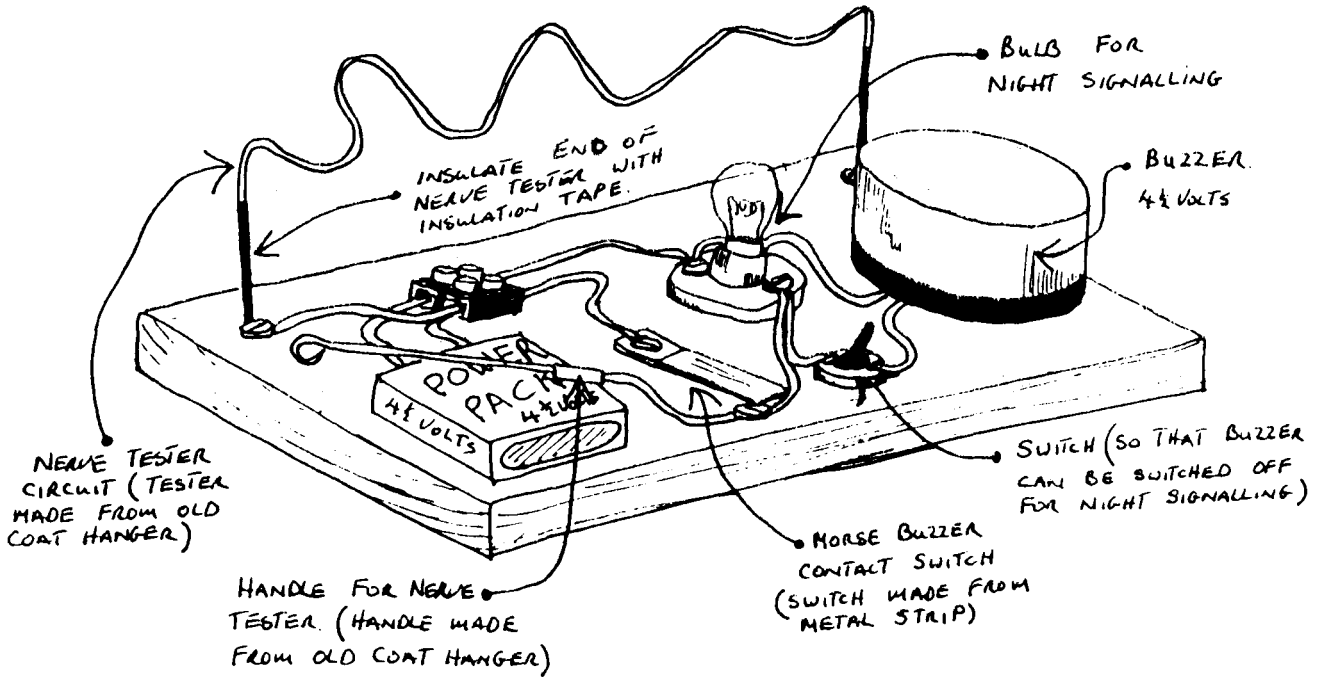

This simple electrical project offers a number of possibilities as a programme activity. The construction of the device, the learning of the Morse code, the sending of messages using this device and perhaps sending signals by torch flashing at night. The device can also be used in a funfair situation or as a game to test the nerve of your Cubs. You aim should be to introduce the concept of signalling and how morse is used as a means of communication rather than try to make the Cubs super efficient morse operators.

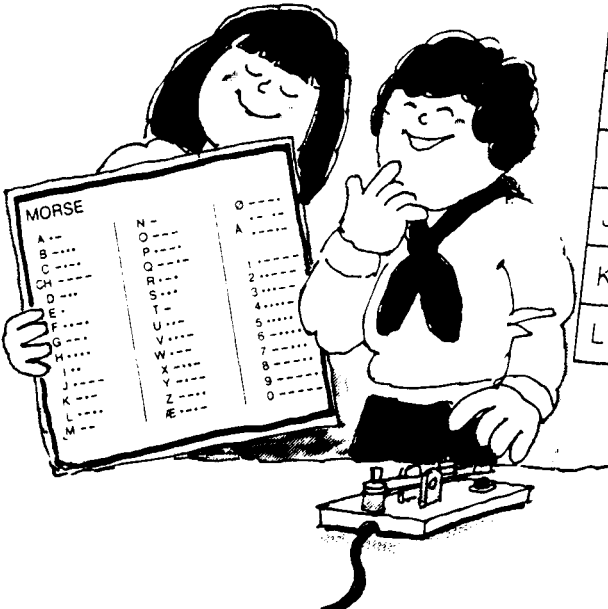

A	● —	M	— —	Y	— ● — —
B	— ● ● ●	N	— ●	Z	— — ● ●
C	— ● — ●	O	— — —	1	● — — —
D	— ● ●	P	● — — ●	2	● ● — — —
E	●	Q	— — ● —	3	● ● — —
F	● ● — ●	R	● — ●	4	● ● ● ● —
G	— — ●	S	● ● ●	5	● ● ● ● ●
H	● ● ● ●	T	—	6	— ● ● ●
I	● ●	U	● ● —	7	— — ● ● ●
J	● — — —	V	● ● ● —	8	— — — ● ●
K	— ● —	W	● — —	9	— — — ●
L	● — ● ●	X	— ● ● —	0	— — — —

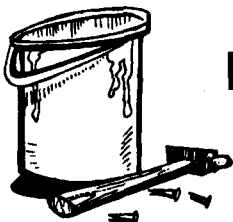

Knotting Boards

Knotting boards can be created to assist your Cub scouts / Macaoimh and Beavers to have a go. Make individual boards (as illustrated) where the knot is tied using two different coloured ropes so that a Cub scout or Beaver can figure out how it is done. A card in the centre explains the many uses the knot while the two ropes dangling from the card invite the viewer to have a go. So that variety can be introduced, the boards can be different colours and rotated or taken down or replaced with others each month if you wish. A variation of the above is the Instant Knot Demonstrator. A few pieces of timber and light poles will help to make a hitching rail where individual pieces of different coloured rope can be fasten to the top and bottom rails to allow the practicing of knots as they are demonstrated. The device can also be used for knot tying races.

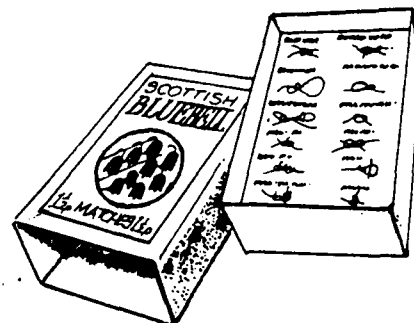
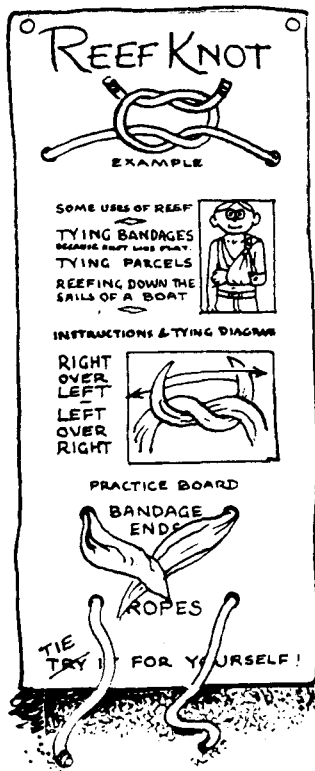
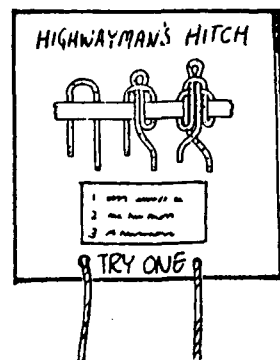
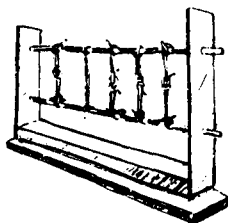

Competition

You could also hold a competition requesting participants to create a knotting board in a matchbox. The challenge is to get as many knots in the matchbox as possible, perhaps having several small knot boards or cards in the matchbox.

Make a whistle

Select a piece of scycamore twig and cut as shown - taking a notch out of the twig and smoothing off the cut edge in a slant as shown. Slice around the bark



Remove bark carefully by sliding it off the twig



Slice of a sliver of the pith from the top to the notch

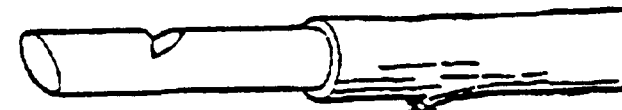

Replace the bark and blow your whistle. It maybe necessary to wet the whistle to obtain proper sound

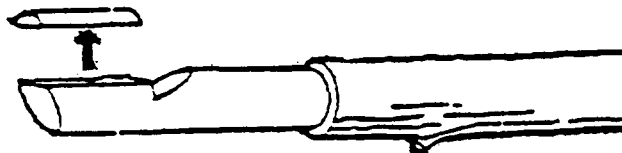

It is possible to make a variable pitch whistle by cutting pith as shown, then is then slide up and down as you blow into the whistle.

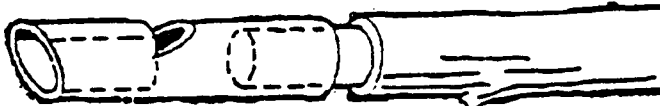

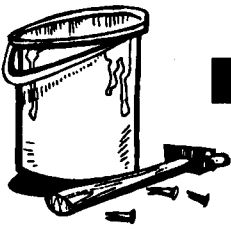

Face Painting

Face painting is an activity that every child loves to do. It is quite simple to do all you need is paints. Face paints are available in most art and craft shops. If possible try to get which are water based cosmetics (not grease), they are slightly more expensive but rare safer and easier to use. Once you have the paints all you need is to add a little imagination and off you go. Apart from the paints you will also need a jar of water, a small sponge, some tissues, a few cotton buds, a smock (to protect clothes) and a few paint brushes for fine details.

There is only one rule in facepainting and that is simple - there is no such thing as a mistake in facepainting - children will love everything.



The Dog

First put down a base colour of white. Wait for it to dry, then apply brown patches as shown. Now apply the black and don't forget the whisker dots to make it look really 'doggy'

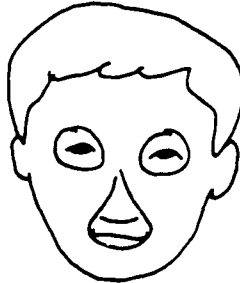

Leopard

First apply a base colour of yellow. Leave areas clear around the eyes, mouth and nose as shown.

Use your brush to fill the area above the mouth white.

Again using the brush apply the black to paint the eyebrows, whiskers, and semi - circles on the cheeks.

Lastly, apply some dabs of red on the nose, in the semi- circles and under the eyebrows

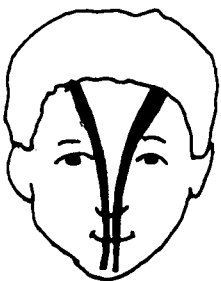

Zebra

Apply a base colour of white. Apply the black as shown. Try to keep the design as symmetrical as possible.

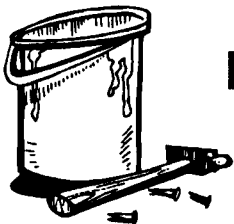

Wild Cat

Apply black to the face as shown.
 Since the cat is wild you can go wild on the colours.
 Apply them in dabs of colour.
 Finish the design off by circling some of the dabs of colour with black.



Rabbits

Apply white to the face as shown
 Add the black eye patches and outline under the white paint and teeth.
 Lastly, add the whiskers and whisker dots. You can also apply some red to the tip of the nose.

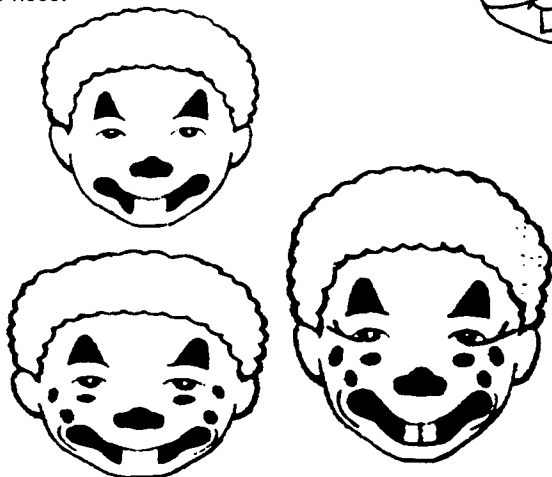

Big tooth

Apply a base colour of white to the face and wait for it to dry.
 Use your fingertip or a cotton bud and apply red to the forehead and mouth
 Apply some coloured dabs to the cheeks
 Outline in black the eyes, teeth, and mouth.
 Lastly, either add a red nose in paint or a plastic one.

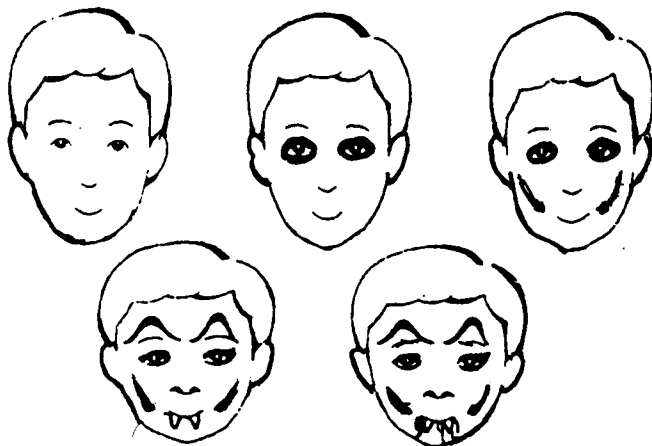

Dracula

Apply a base colour of white to the whole of the face.
 Using a sponge or your finger apply a pale purple to the eyelids and across the cheeks so as to create high cheekbones.
 Deepen the purple shadows with a little lightly rubbed in on top of the purple.
 Now using your brush draw in arched eyebrows, fangs and nostrils in black.
 Lastly, add the blood drooling from the mouth, not too much just a hint.



Frankenstein

Apply a blotchy base of white to the face
 Add black around the eye hollows
 With a sponge add a light green to the face here and there
 Add stitches and scars as required.

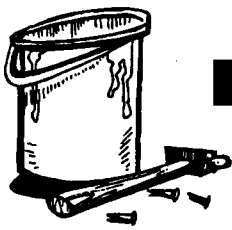

Adventure in the out of doors



CONTENTS, SURVIVAL KIT:



20 FT. NYLON FISHING LINE, AND 10 FT. THIN WIRE, ON 2 CARDS LIKE THIS.



3 FLYHOOKS

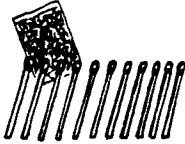

10 MATCHES DIPPED IN MELTED CANDLE WAX, AND SIDE OF MATCHBOX... ALL WRAPPED IN FOIL.

2 MEAT EXTRACT CUBES, FOIL WRAPPED. SMALL COIL OF WIRE
 6 "ELASTOPLAST" DRESSINGS
 4 MULTIVITAMIN TABLETS, IN A FOIL TWIST. OZ. SALT IN FOIL TWIST. 3 OZS. RICE. ROLLS IN SMALL PLASTIC FOOD BAG, SEALED TIGHT WITH STICKY TAPE. 2 NEW RAZOR BLADES, WRAPPED. 4 20P COINS FOR PHONE EMERGENCY. TINY PHIAL ANTISEPTIC OINTMENT. TINY MAGNIFYING GLASS. TWO 18" SQUARES ALUMINIUM FOIL, FOLDED SMALL. ALL WRAPPED IN PLASTIC FOOD BAG ABOUT 12" X 9", WITH CARD CONTAINING YOUR NAME, ADDRESS.

PACK INTO YOUR POUCH WITH THIN PLASTIC SHEET, 4 FT. X 3 FT. CARRY POUCH ON PERSON, AT ALL TIMES WHEN OUTDOORING.



SCARF, CLASP KNIFE AND CORD SHOULD ALWAYS BE ON YOUR PERSON TOO. IF YOU CAN AFFORD A MODERN "RESCUE BLANKET" ADD IT! NOTE: A BICYCLE SADDLE POUCH, FIXED TO YOUR BELT, IS IDEAL FOR THIS KIT!

SURVIVAL KIT BELT POUCH

FRONT VIEW

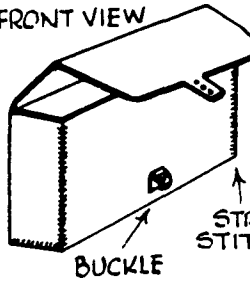

BACK VIEW

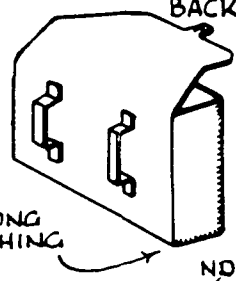

BUCKLE

STRONG STITCHING

NDUKU

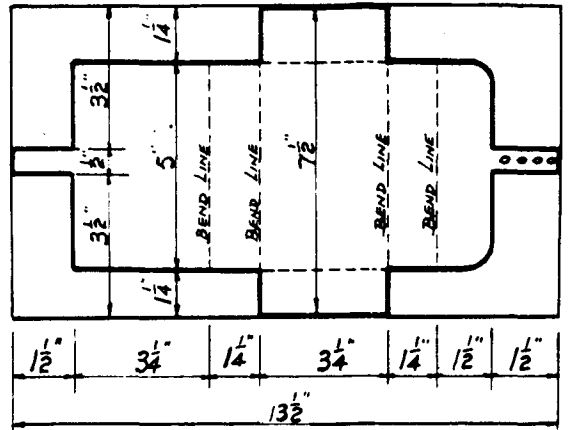

USE A REASONABLY THICK PIECE OF LEATHER 13 1/2" X 7 1/2". STITCH WITH STRONG WAXED STRING, OR NYLON. STITCH ON SMALL BUCKLE STRIP - AND RIVET BELT LOOPS TO BACK. STRIPS ARE CUT FROM LEATHER PIECES LEFT OVER.

Simple First Aid Kit



Cotton wool wrapped in foil



Antiseptic solution



Antihistamine ointment

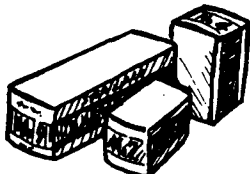

Prepared sterile dressings

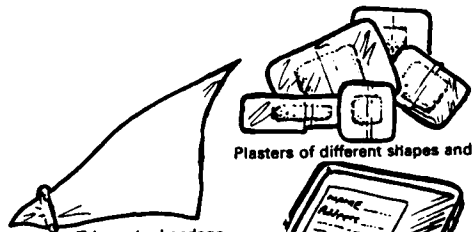

Plasters of different shapes and sizes

Triangular bandage



Coins for telephone (2p and 10p)

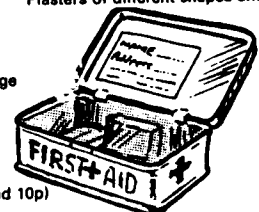

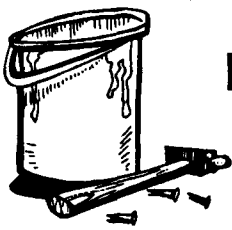

Make a mini pup shelter

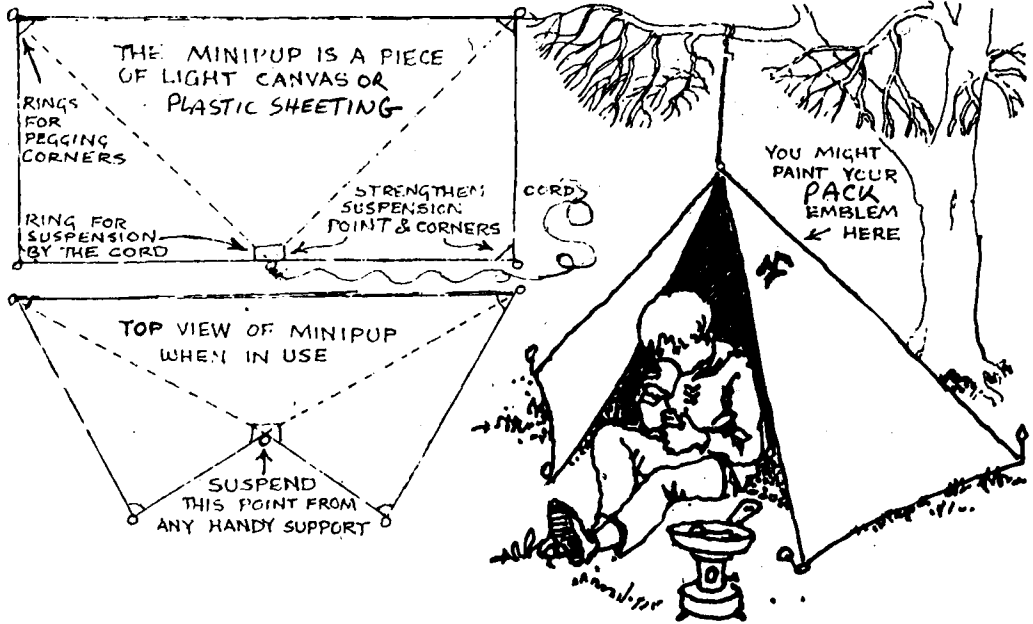

Cook backwoods style

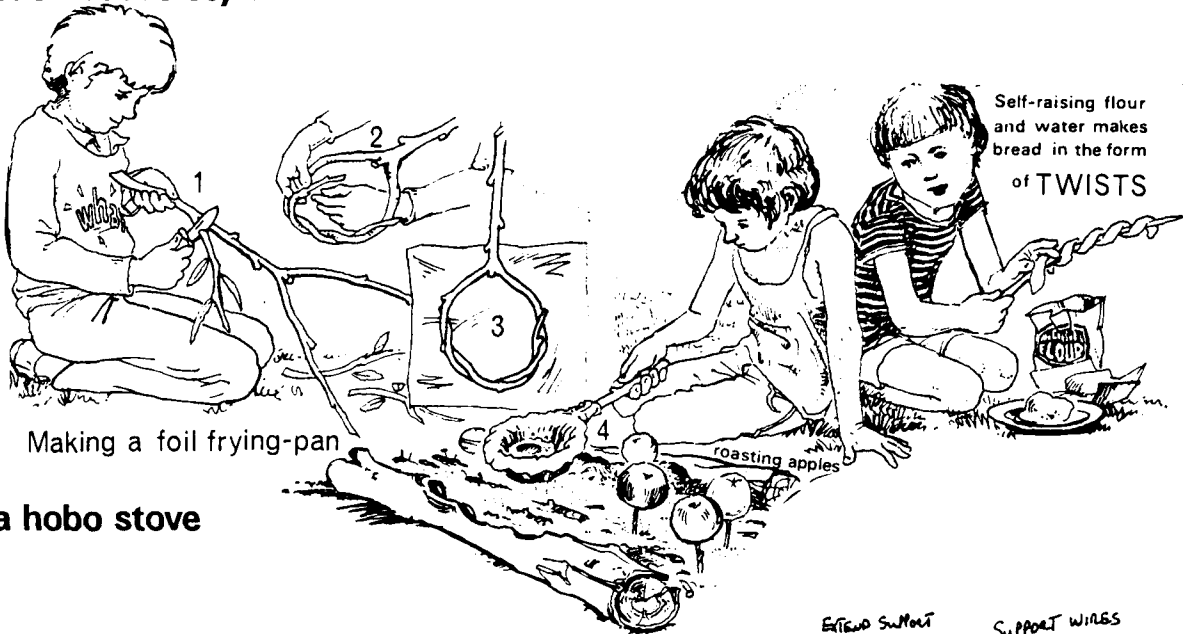

Make a hobo stove

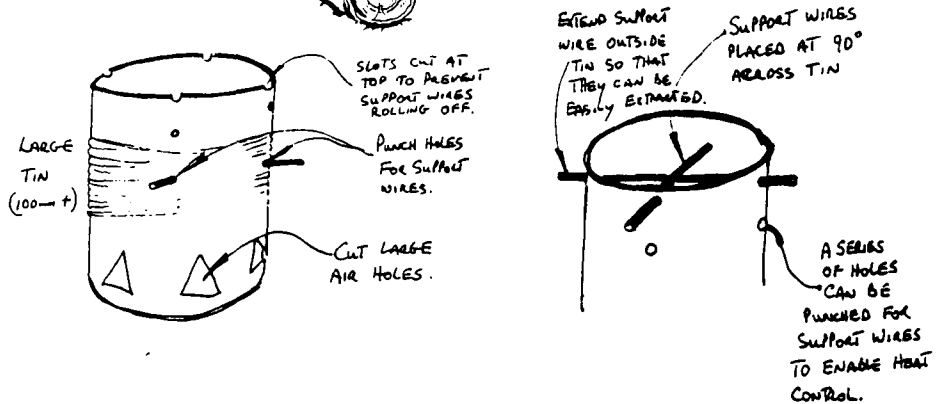

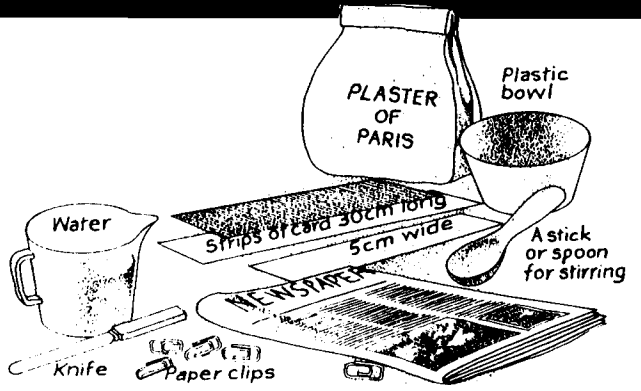
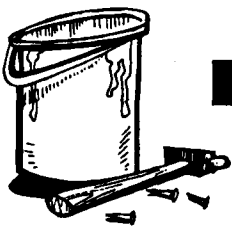

Tracking and Trailing

Make a plaster cast of an animal track

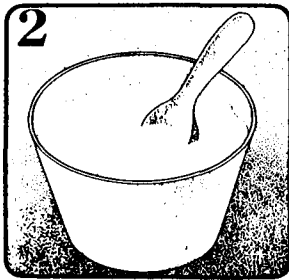
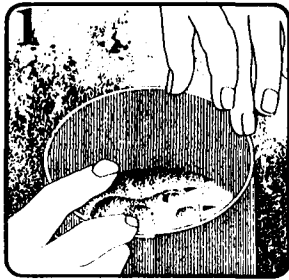

1. When you find a track place a mould around it made of thin card, secure with paper clip
2. Mix up your plaster of Paris and pour into mould
3. Leave the cast to dry for at least 15 mins.
4. When cast is set lift it carefully from the ground with the edge of a knife. Brush off any mud or dust. The cast can be washed when completely dry.

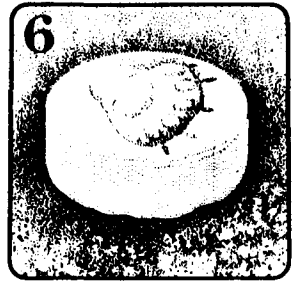
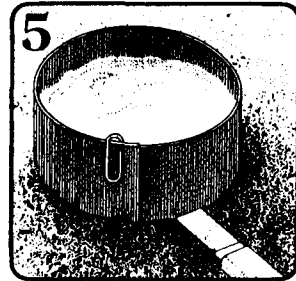

5. You may wish to create a negative image from your original positive cast this can be done at home using same technique. Smear a little Vaseline over the original to prevent the two casts sticking together.
6. Your final cast can be protected by painting with varnish.

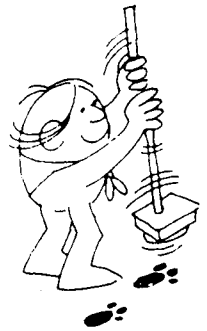
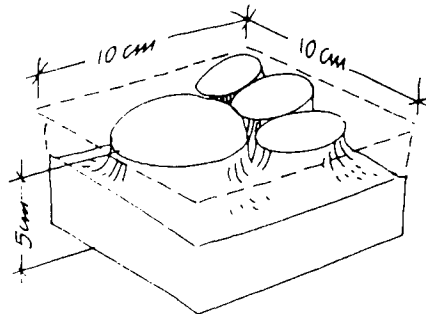

If you difficulty find tracks then make your own by constructing a tracking devise as shown out of some scrap timber.

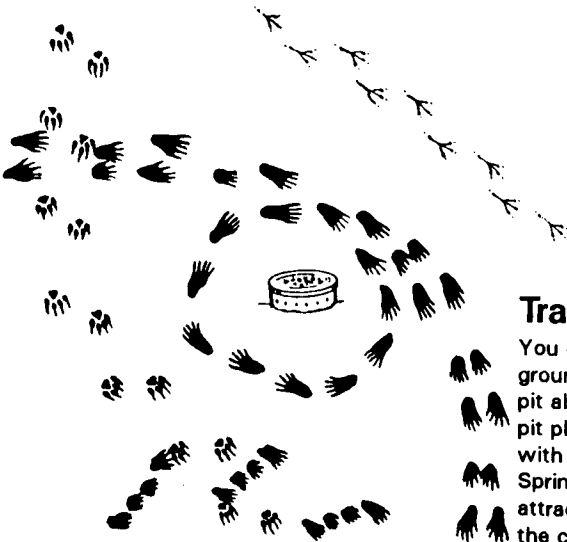

Tracking pit

You can create your own tracking pit in open ground . This is done by first preparing a sand pit about 2 metres square. In the centre of the pit place a small tin upside down in the pit with the top about 25mm above the ground. Sprinkle some bird seed on top of the tin to attract birds. If you place some meat or fish in the can and punch some holes above soil level you will attract some bigger animals

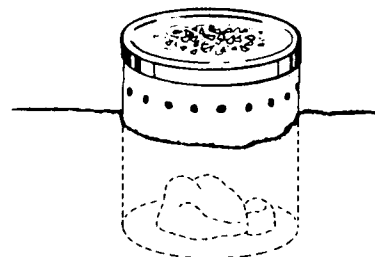

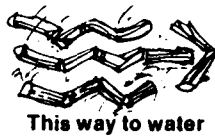
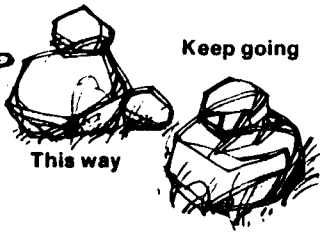
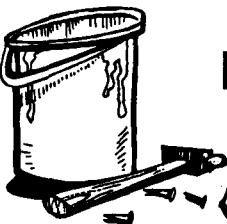

Animal tracks

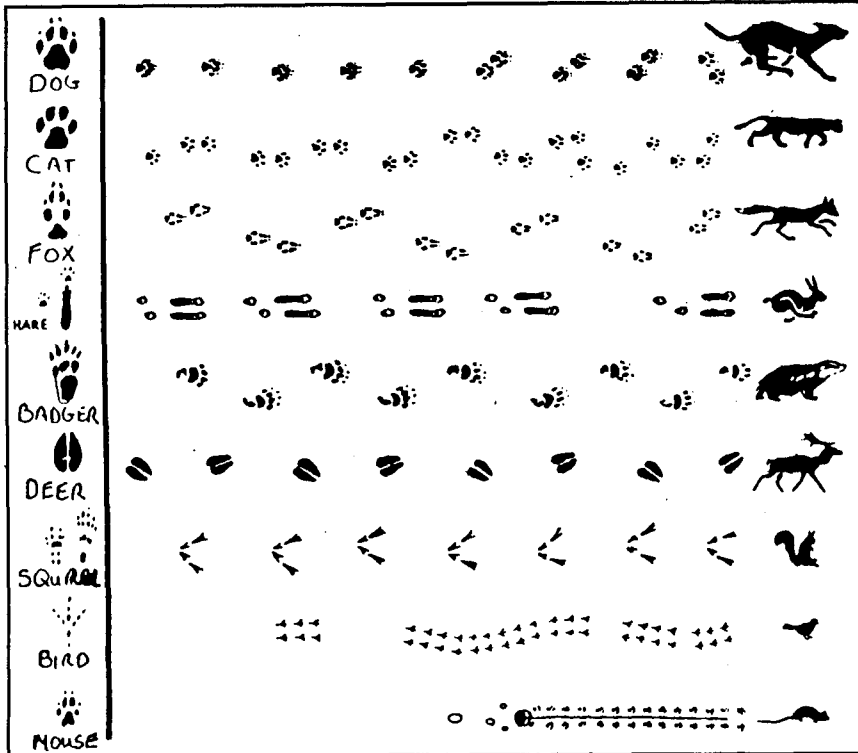

Tracking signs

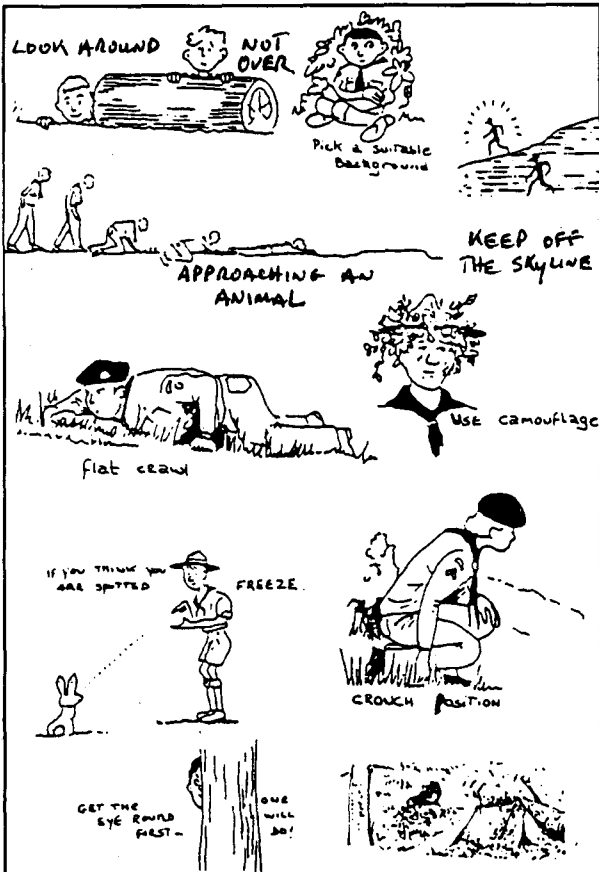
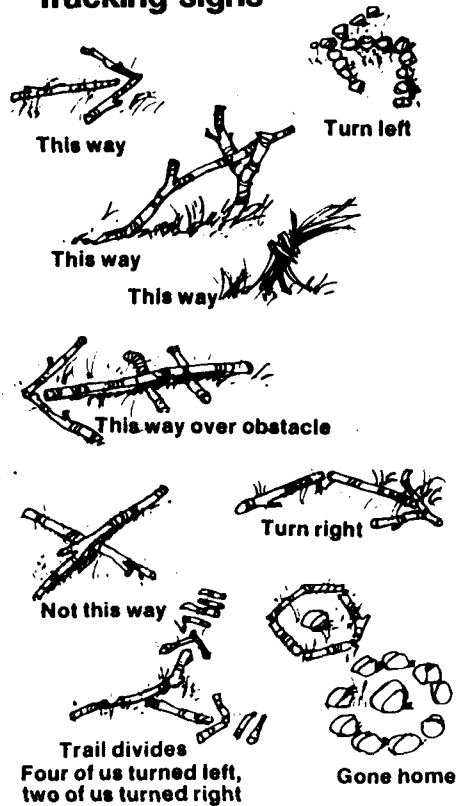

How to stalk

When stalking animals remember that the crack of a twig or a flicker of movement will alert your prey. Move silently and smoothly keeping to cover as much as possible. Keep off the skyline and stay down wind - animals have an acute sense of smell.

Making a hide

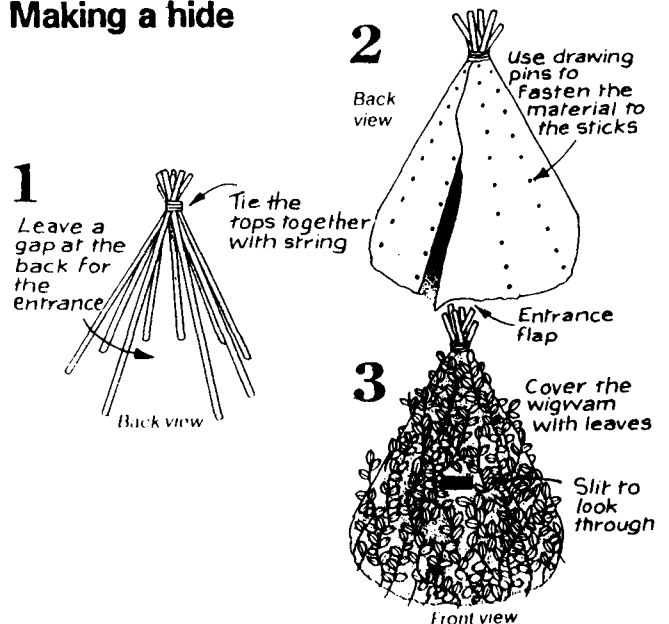

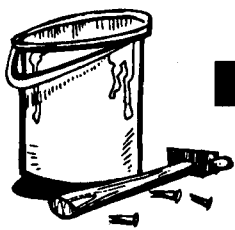

Many uses for plastic bottles

Plastic drinks bottles can be used to create a number of useful items. First the labels need to be cleaned off the bottles. Soak the bottle in hot water to which detergent has been added for approx. 15 mins. The labels can then be peeled off. There may be some small pieces of glue left on the bottle and these can be removed with a rag dipped in a little methylated spirit. If you are using the type with a hard plastic base this can be removed by pouring some hot water into the bottle. The hot water will soften the glue on the base and the base can be removed with a twisting action.

It is the bottle's ability to be cut in dozens of different ways and retain its original shape that lends it to so many end uses - toys, terrariums, hanging gardens, plant starters, jelly moulds, money boxes and so on.

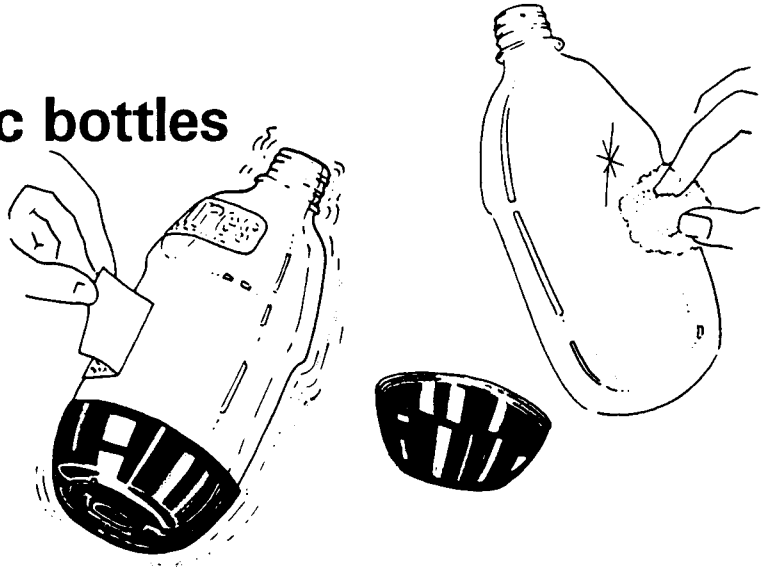

Wise old owl

To make a 'wise old owl' cut the plastic bottle about half way between the covered bottom and the shoulder. Sketch on the inside of the bottle the outlines of feathers, eyes, beak and wings using a black permanent marker. Paint the eyes and beak with white, then once it is dry paint the entire inside in light brown. Invert the top into the base cup to complete.

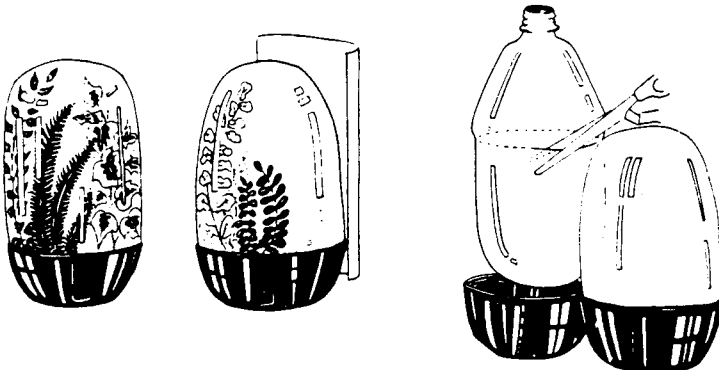
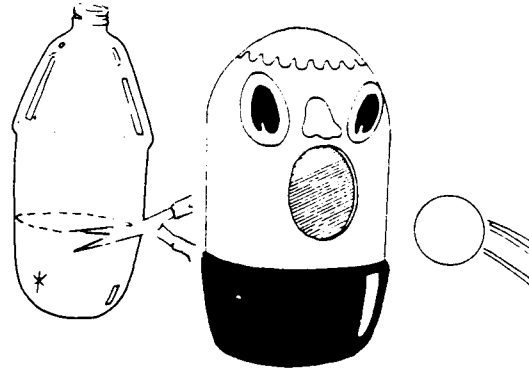
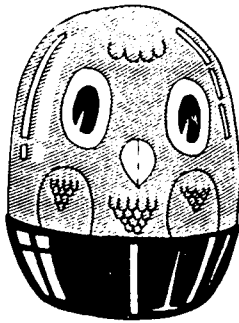

Ball game

Cut the plastic bottle as for the 'wise old owl' and paint the desired face inside, cutting a hole for the mouth. The hole should be larger than a table tennis ball so that the ball will go through when thrown at the target. Invert the top into the base cup as before and enjoy some target practice.

Terrariums

Plastic bottles provide an ideal opportunity for children to study plant life in a terrarium situation. To make the terrarium remove the base cup and cut the plastic bottle in half just below the shoulder, about two thirds up the bottle. The inverted bottle placed inside the base cup forms the terrarium. The base can be filled with soil then planted with seeds and plants. They can note how some seeds germinate in the terrarium as compared with an uncovered base cup alongside containing the same soil, seeds and sunlight conditions. Miniature gardens scenes can be developed using moss, figurines and small plants. If the bottle is hung sideways a wide selection of plants can be grown much like a hanging basket.

THISTLE SEED FEEDER

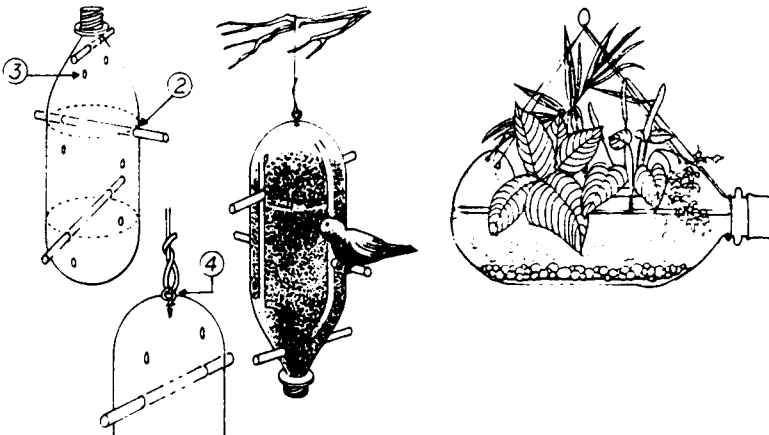

Bird feeders

Plastic bottles can also be used to make bird feeders. They can be simple in construction with just holes cut or drilled into the bottle from which seed can be eaten by the bird to the more elaborate model which provides purpose made spouts and perches. A simple method of drilling holes in the bottles is to use a hot metal skewer.

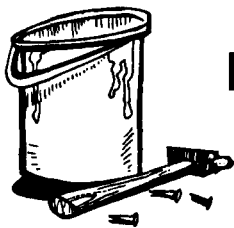

Spy Kits

These spy kits can be constructed by your Cub Scouts or Beavers for use as part of a spy theme or wide game. All the equipment is contained in a match box. It holds an invisible writing kit, hollow twig disguise for secret messages, code card, and all you need for signpost signals. Make three mini-pens - a pencil for code messages, a bit of white crayon or candle for wax writing and chalk for signpost signals. Then make dividers and a lifting string for fast action in emergencies.

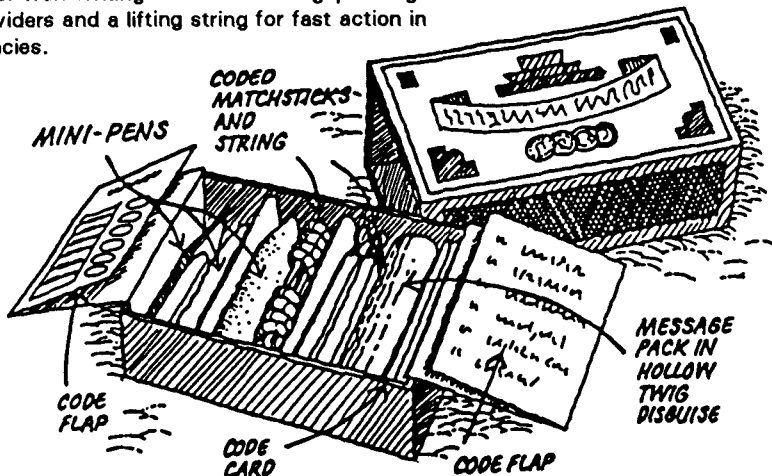

Making Mini-Pens

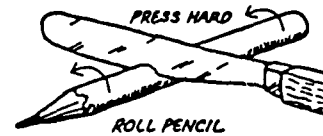

To cut down a pencil, chalk or bit of candle, saw round with a knife to make a deep groove. Then, you can break it here.

1 Code Flaps

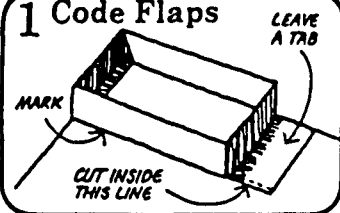

Draw round the matchbox on some card, leaving a bit extra. Cut out a strip slightly narrower than this. Do this twice.

Matchstick Holder

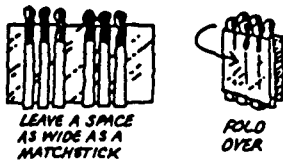

Lay six coded matchsticks (broken to size) on a bit of sticky tape, leaving a space in the middle. Fold the strip as shown.

For container you will need:-

- A matchbox
- Stiff paper or thin card (a postcard is good)
- Scissors and a pencil
- Strong glue and Sellotape
- Needle and thread for the lifter

2

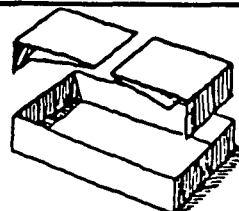

Fold the strips so that the folded flaps will fit together in the tray when you close the box. Bend down the tabs and trim.

String Holder

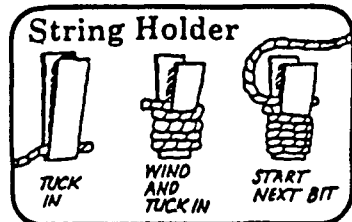

Tuck the end of the string into the fold of a strip of card, cut to size. Then wind it round and tuck in the other end.

Message Pack



Cut strips of paper a bit narrower than the tray. Wind tightly round a matchstick, one by one. Tuck into the hollow twig.

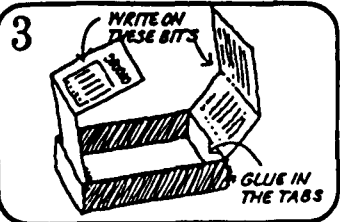

Write the codes on one flap and the meanings on the other. Then glue the tabs into the tray.

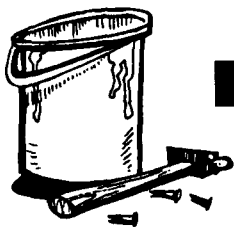

Water scope

MATERIALS: LENGTH OF PLASTIC PIPE ABOUT 60cm. (24ins.) LONG, WITH 8cm (3¼in.) DIAMETER.

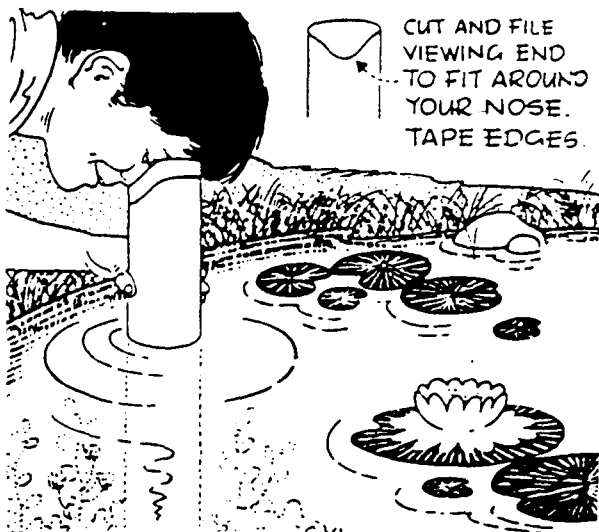
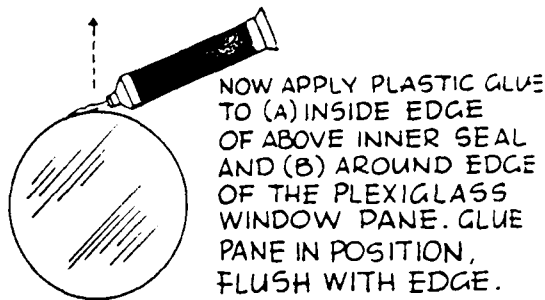
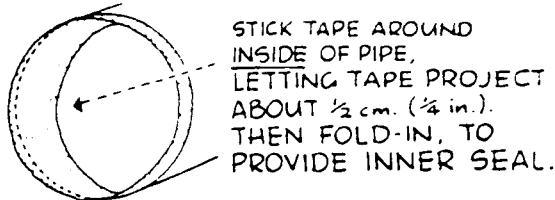
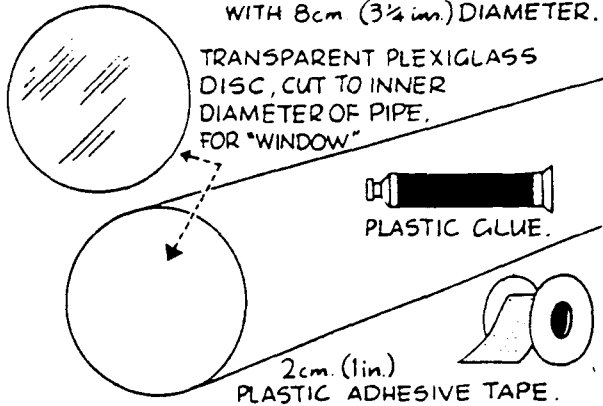

NOW RUN PLASTIC TAPE AROUND THE OUTSIDE OF THE PIPE, ALLOWING TAPE TO EXTEND ABOUT ½ cm. (¼ in.).

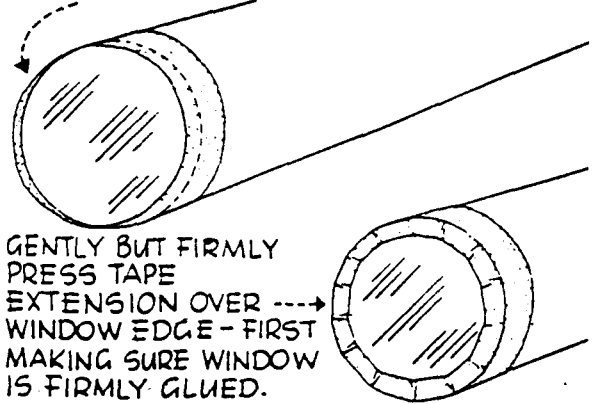

Periscope

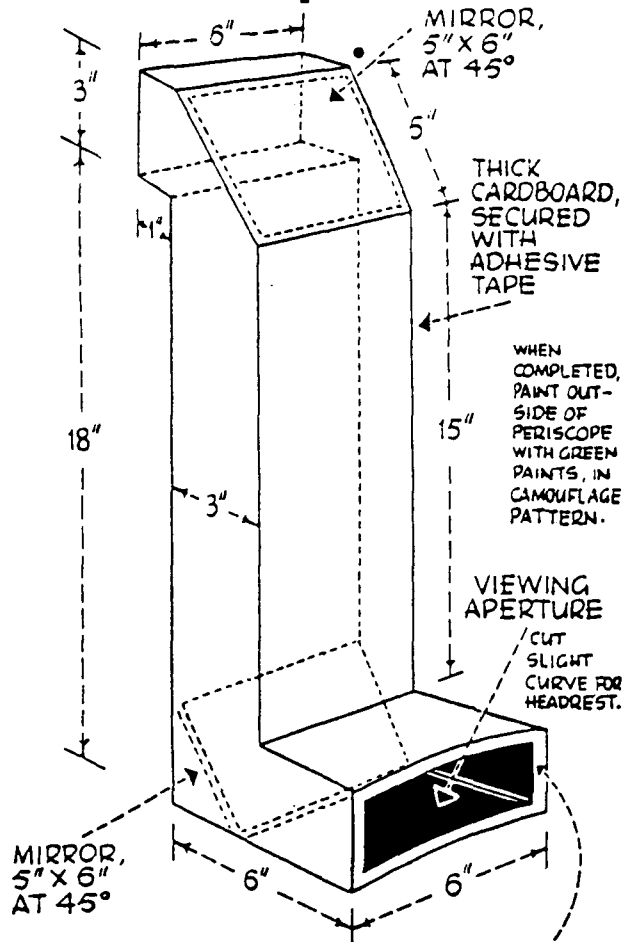

BEFORE ASSEMBLING, PAINT ALL INSIDE PIECES OF CARD WITH FLAT BLACK (BLACKBOARD) PAINT.

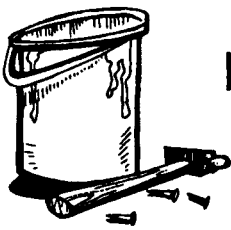

Bird Tables

This is a good service to wildlife all year round, but especially during times of drought, and during the winter. In winter, feeding should start early to attract the birds. Once started, it must be continued until the spring - because the birds will depend on the supply.

Locate your feeding and drinking stations close to trees and scrubs - birds need nearby cover when larger birds such as crows and seagulls are in the area. They should also be away from cats and dogs. When making and placing out nesting boxes in your garden, or permanently outside your den, or elsewhere, here are a few points to remember:

- Make sure that boxes are firmly attached.
- Do not drive nails into valuable trees. Fasten the boxes without damaging the trees.
- Tilt the box slightly forward, to prevent rain getting in, and make sure the box is not leaking at the joints.
- Face the entrance hole on the lee side, away from the prevailing wind.
- Clean the boxes once a year.

LITTER'S FOR THE BIRDS!

SUSPENDED ON WIRE, HELD INSIDE CAP BY A WASHER HANG IN A TREE

A SIMPLE FEEDER CAN BE MADE FROM A SHALLOW TIN CAN...

BETTER, MAKE A MORE ELABORATE MODEL, WITH ROOF AND PERCH

LOCATE ALL FEEDERS, BIRDBATHS E.T.C. NEAR COVER SUCH AS TREES AND SHRUBS

A BIRDBATH CAN BE MADE FROM ANY LARGE SHALLOW VESSEL, SUCH AS THE BASE OF A PLASTIC DRUM, OR AN OLD RUBBISH BIN LID, SET ON A ROCK PEDESTAL. CLEAN AND REFILL BATH EVERY MORNING.

BIRDBATHS CAN BE MADE FROM ALMOST ANY KIND OF BOX OR OTHER CONTAINER FROM A SIMPLE WOODEN BOX OR A TIN CAN TO A PLASTIC BOTTLE OR A DRIED CALABASH GOURD

COFFEE CAN BIRDBATH WITH WOOD OR HARDWOOD ROOF

PLASTIC OR TIN CAN WITH WOOD AND PERCH

BIRD FEEDING STATIONS CAN BE MADE FROM LARGE PLASTIC BOTTLES "ROOFED" TO PROTECT THE BIRD SEED AND BREAD CRUMBS FROM RAIN

FILL WITH A "FLOOR" OF CLAY OR PLASTER OF PARIS

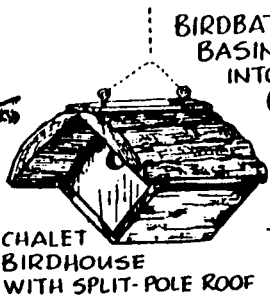
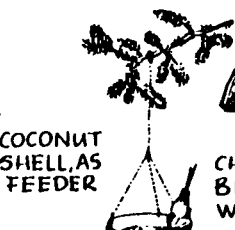
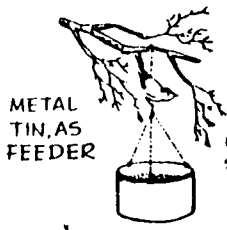

BIRDBATH MADE FROM BASIN CEMENTED INTO ROCK BASE. (BUILD IT HIGHER TO DISCOURAGE CATS, DOGS).

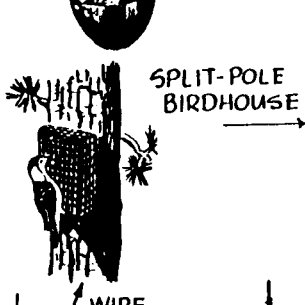
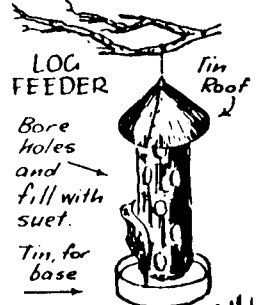
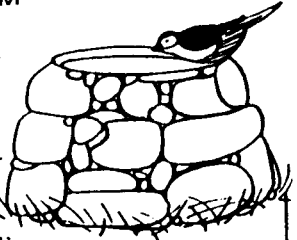

REMEMBER... LOCATE ALL BIRDBATHS, BIRDBATHS AND FEEDERS CLOSE TO COVER, TO PROVIDE BIRDS WITH REFUGE FROM PREDATORS. TREES AND SHRUBS PROVIDE IDEAL COVER.

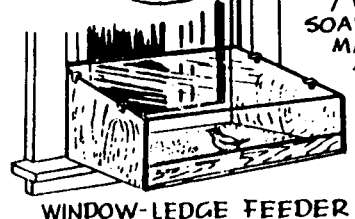

WIRE SOAP HOLDER MAKES A SUET FEEDER

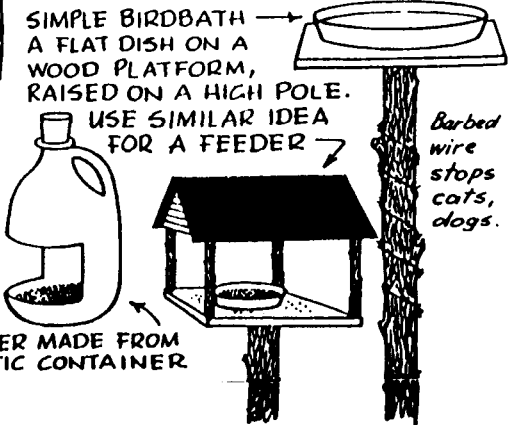
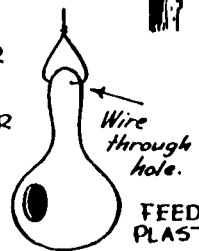

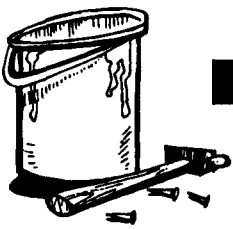

Flower Press / Bark rubbing

The countryside abounds in wild flowers, trees, rivers etc. Collect items for you scrape or nature book on your next expedition to the countryside. Items can be collected in plastic bags to preserve them before they can be placed in your notebooks.

Bark rubbings can be taken directly from the tree by simply holding a sheet of paper against the trunk and firmly rubbing the side of a soft brown or black crayon over the paper, being careful to hold the paper still.

Leaf rubbings can be made in a similar fashion using a soft green or yellow crayon

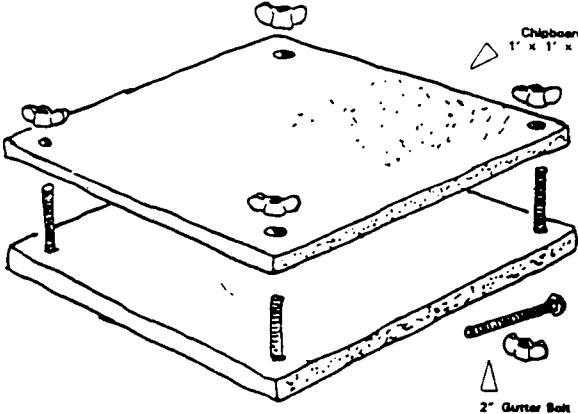
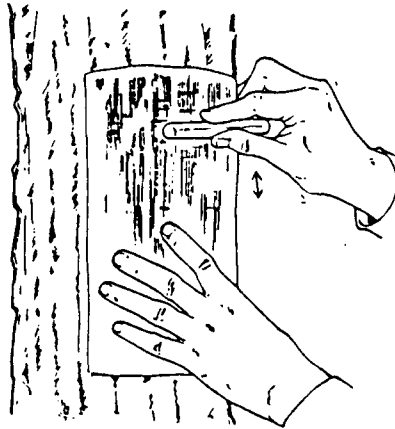

Flower Press

To prolong the life of your leaves and flowers why not make a flower press. You will need

- 2 No. 30cm X 30cm pieces of chipboard
- 4 No. 50mm Gutter bolts
- 4 No. Wing nuts
- Tissue Paper and newspaper.

It will be necessary to leave flowers etc. in the press for approx. 14 days to dry. When dry mount leaves and flowers on cardboard and cover with clear 'sticky' plastic.

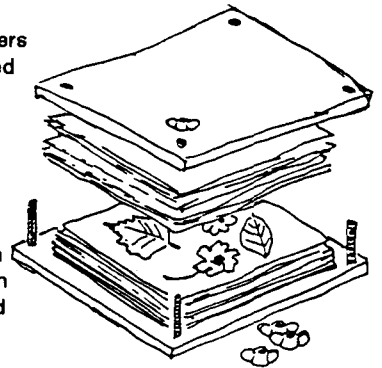

The Wind

Anemometer

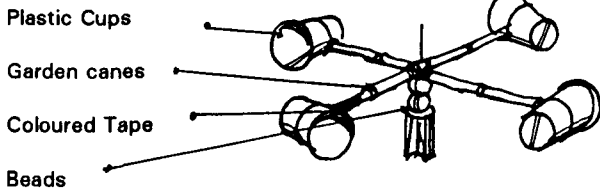

Count the number of times per minute the cups revolve.

Wind Sock

When you want to find the speed and direction of the wind

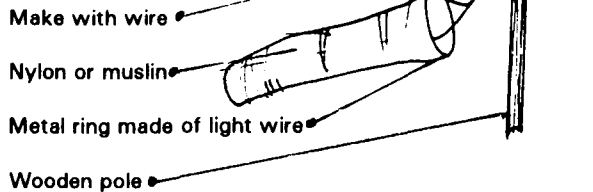

The Wind Vane

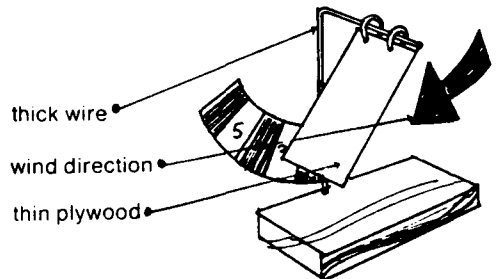
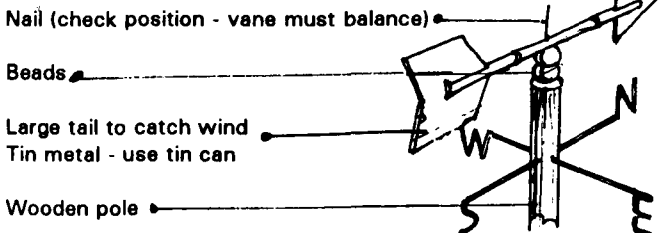

This instrument measures wind strength.

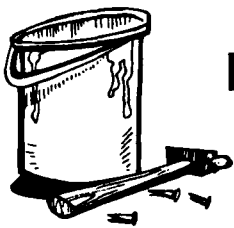

Nutty People

The whole idea of this activity is to create a sort of menagerie of strange and comic creatures - including people. It will add a lot to the humour if you make little 'place cards' to tell others what they are supposed to be. Sometimes the materials that you are using will give you ideas.

First a word of warning!!! - On no account should you allow anyone to hold anything in their hand when they are trying to put a hole in it with a skewer. Insist on all 'drilling' being done on the base board with a piece of cloth to prevent slipping.

This is an ideal autumn activity when acorns, nuts, seed pods etc, you have gathered on your nature expeditions can be used. You will need a sharp skewer, a pad of cloth, a base board, a supply of dead matches and a knife to sharpen the ends, some glue and odds and ends.

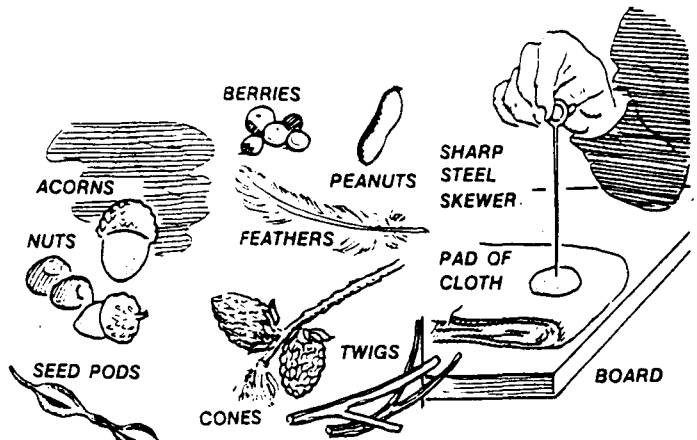

SCOT



THE PENITENT



RUINED!



GERM

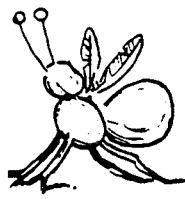

MOSQUITO

CHARACTER STUDIES

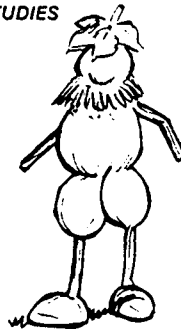
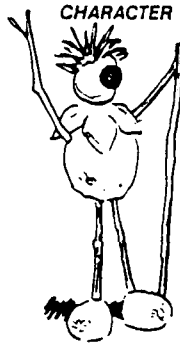

CHINESE

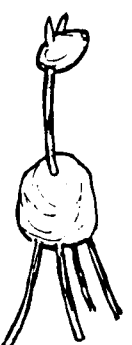

GIRAFFE

Pebble People

Collect some pebbles and turn them into faces.

Beach pebbles are usually very smooth because they have been rubbed together for a long period because of the tides. They can be found in a wide variety of shapes, sizes and colours. When you have a collection of pebbles, sit and look at them for a while. You'll find their shapes suggest ideas to you - fish, animals, people and so on.

Once you have an idea for your pebble, you might find it useful to pencil in your design. The next stage is to paint it. Some pebbles have good, natural colours and you might want to use part of the natural colouring for your finished product. Enamel paint is probably best. Poster paint rubs off if it is water based, so try a few test dabs on spare pebbles before you settle on your finished product.

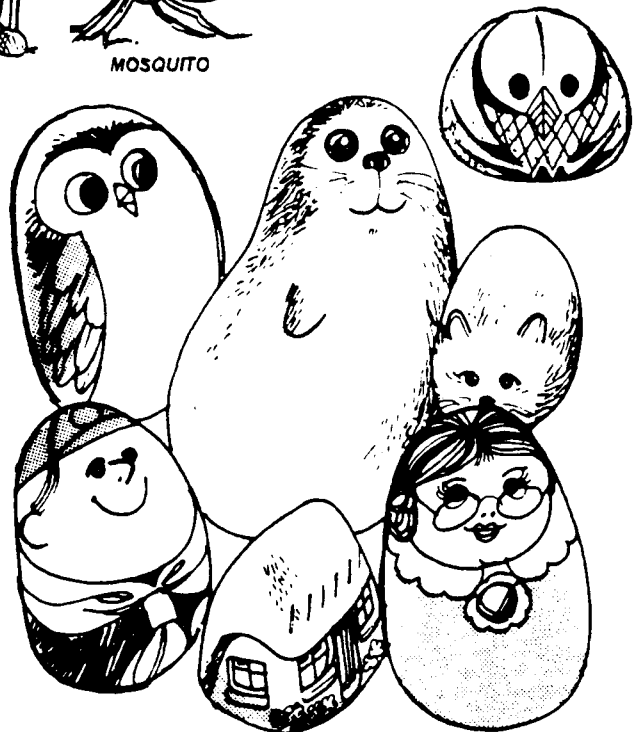

Large pebbles can be painted to make attractive paperweights. Do not be in too big a hurry and let one colour dry before you put another alongside it. When it is finished and thoroughly dry you should give it a coat of varnish.



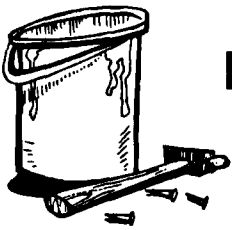

Cork Models

'GIRAFFE'

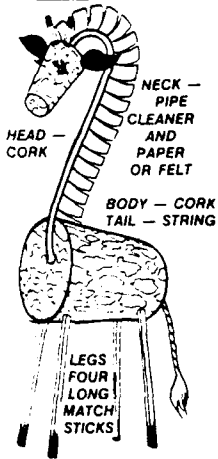

HEAD - CORK
NECK - PIPE CLEANER AND PAPER OR FELT
BODY - CORK
TAIL - STRING
LEGS - FOUR LONG MATCH STICKS

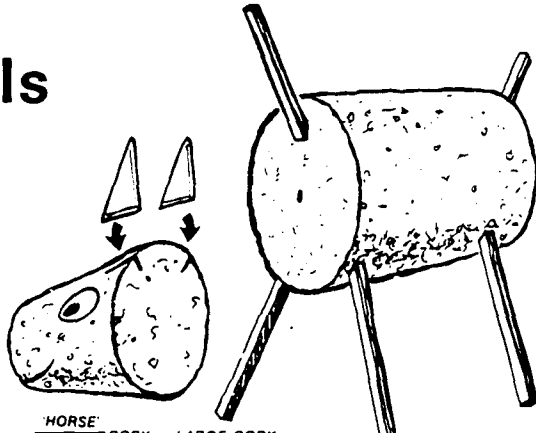

'HORSE'

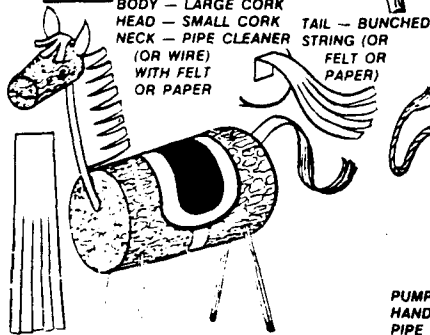

BODY - LARGE CORK
HEAD - SMALL CORK
NECK - PIPE CLEANER
TAIL - BUNCHED STRING (OR FELT OR PAPER)
OR WIRE WITH FELT OR PAPER

'MAN'

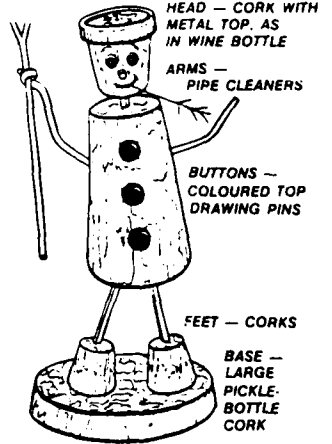

HEAD - CORK WITH METAL TOP, AS IN WINE BOTTLE
ARMS - PIPE CLEANERS
BUTTONS - COLOURED TOP DRAWING PINS
FEET - CORKS
BASE - LARGE PICKLE-BOTTLE CORK

'COMPOSITE TOY ANIMALS DRINKING'

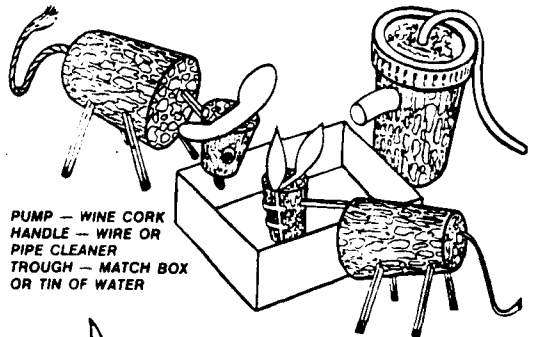

PUMP - WINE CORK
HANDLE - WIRE OR PIPE CLEANER
TROUGH - MATCH BOX OR TIN OF WATER

'SWAN'



HEAD - SMALL CORK
NECK - PIPE CLEANER (OR WIRE)
BODY - HALF LARGE CORK
WINGS AND TAIL - SMALL FEATHERS

'FISH'

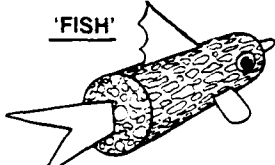

BODY - CORK
TAIL & FINS - MATCHBOX PIECES (OR MILK BOTTLE TOPS CUT TO SHAPE)

'PORCUPINE'

HALF CORK

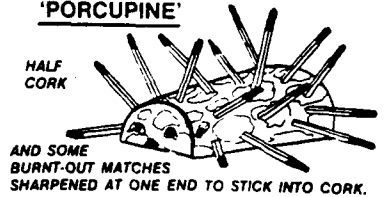

AND SOME BURNT-OUT MATCHES SHARPENED AT ONE END TO STICK INTO CORK.

'COW'

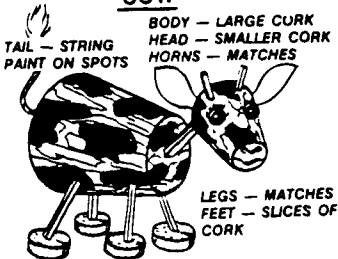

BODY - LARGE CORK
HEAD - SMALLER CORK
HORNS - MATCHES
TAIL - STRING
PAINT ON SPOTS
LEGS - MATCHES
FEET - SLICES OF CORK

'KANGAROO'

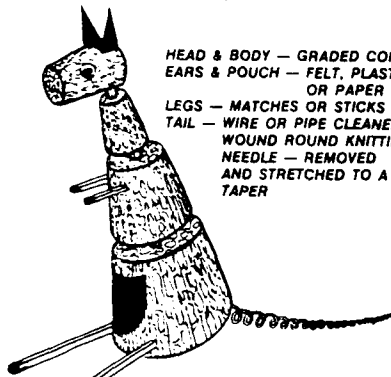

HEAD & BODY - GRADED CORKS
EARS & POUCH - FELT, PLASTIC OR PAPER
LEGS - MATCHES OR STICKS
TAIL - WIRE OR PIPE CLEANER
WOUND ROUND KNITTING NEEDLE - REMOVED AND STRETCHED TO A TAPER

'DUCK'



HEAD - SMALL CORK
BODY - LARGE CORK
NECK - PIPE CLEANER
LEGS - MATCHES
BEAK - PLASTIC (OR CARD)
FEET - SLICES OF CORK
WINGS & TAIL - SMALL FEATHERS

'CROCODILE'

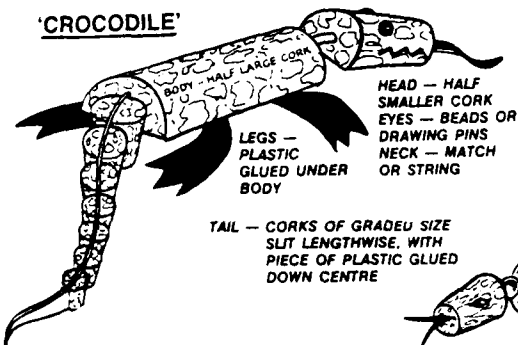

HEAD - HALF SMALLER CORK
EYES - BEADS OR DRAWING PINS
NECK - MATCH OR STRING
LEGS - PLASTIC GLUED UNDER BODY
TAIL - CORKS OF GRADEU SIZE SLIT LENGTHWISE, WITH PIECE OF PLASTIC GLUED DOWN CENTRE

'DACHSHUND'



BODY - LARGE CORK
HEAD - SMALLER CORK
LEGS - MATCH STICKS
EARS & TAIL - SCRAPS OF FELT

'SNAKE'

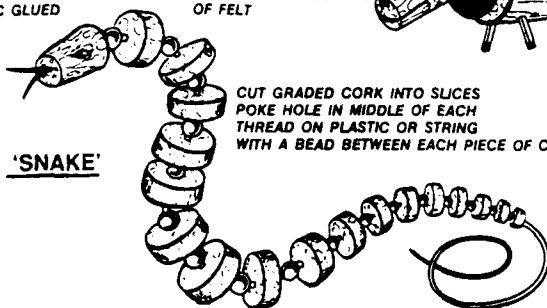

CUT GRADED CORK INTO SLICES
POKE HOLE IN MIDDLE OF EACH
THREAD ON PLASTIC OR STRING
WITH A BEAD BETWEEN EACH PIECE OF CORK

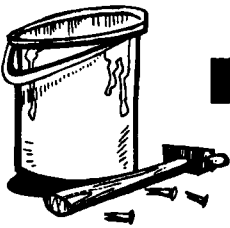

Musical instruments

You may not be a famous conductor, and your lot may not sound like a Symphony Orchestra, but music provides a source of enjoyment that most people can relate to at some level. Once the instrument are made (an exercise in itself even the apparently unmusical child can provide elementary rhythm accompaniment to the melodies of the more accomplished.

Perhaps the more talented could form a band on a more permanent basis. We have presented here a number of instruments which can be built with little effort.

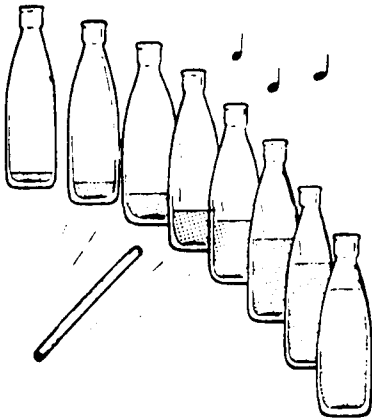

Bottle xylophone

Collect eight empty glass bottles, and suspend them on a strong wooden frame, along the lines as shown in the diagram.

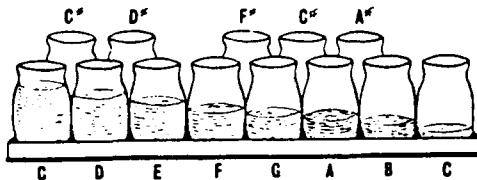
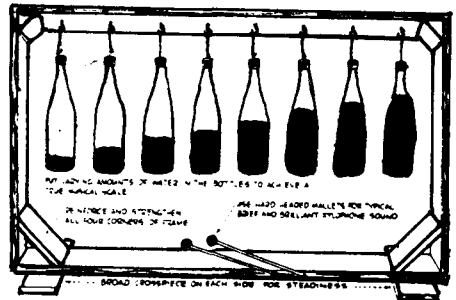

Maracas

Maracas can easily be made from a variety of containers and a handful of dried peas, rice or nails. Test out different containers for different sounds, tin boxes can give a harsh sound while plastic bottles can be a bit quieter.

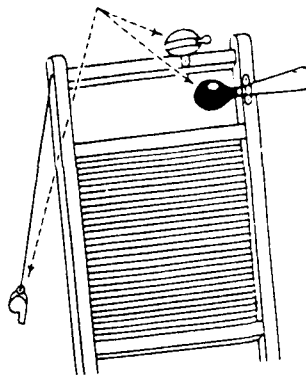

MAKE TWO "SAND BLOCKS" LIKE THIS.

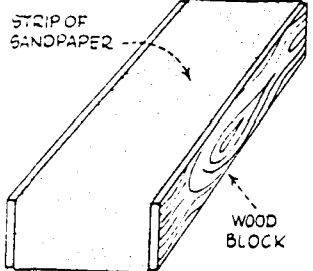

USE DRAWING PINS TO FASTEN SANDPAPER TO WOOD BLOCK, AT EACH END.

Shakers

A variety of instruments can be used as shakers. You will need something that makes a rattle. Metal bottle tops will work excellently. Remove piece of plastic or cork from inside of cap before use.



METAL DISCS... BIG BUTTONS OR BEADS... ANYTHING THAT RATTLES. STRING THEM ON A WIRE, SO THAT THEY SLIDE.

Scrapers

It would be hard nowadays to find a traditional wash board however a similar board can be made of corrugated cardboard glued onto a sheet of wall board. Fun items such as a horn, cycle bell or whistle could be attached to provide sound effects. A notched stick can be played using a nails. If possible use a piece of bamboo as it adds to the sound produced. An instrument which is very simple to make and play, but which gives a very pleasant 'shuffle' rhythm is a sand block.

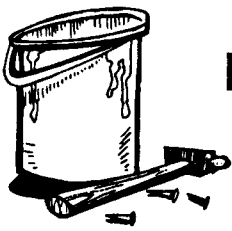

Percussion

We have included a number of ideas for constructing percussion instruments - anything that can be beaten together to make a sound.

Cymbals are marvellous for dramatic effect. Two old tin plates can have holes bored in them and rope handles attached. Old saucepan lids can also be used.

Rhythm sticks

Rhythm sticks should measure about 300mm long and can be made from 10mm dowelling. Smooth down rough edges and paint. To play just click together.

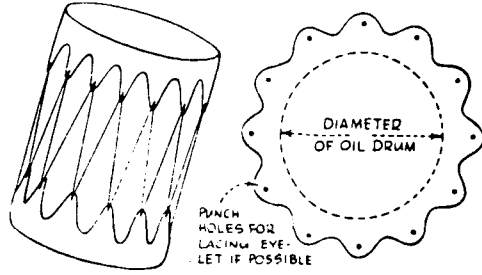
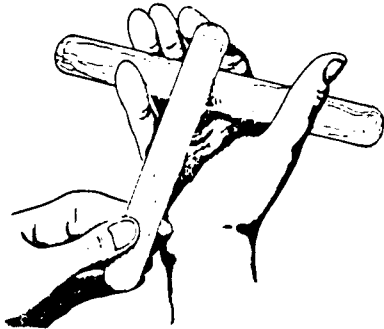
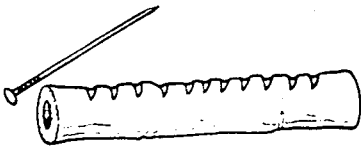

OIL DRUM, ABOUT 20 LITRES, WITH ENDS CUT AWAY, AND RUBBER INNER-TUBE (OR RAWHIDE) DRUMHEADS LACED ON. IF YOU USE RAWHIDE (SKIN), WET IT WELL BEFORE LACING ON ... IT WILL TIGHTEN AS IT DRIES.

CUT DRUMHEAD AS SHOWN ABOVE, ALLOWING ADEQUATE OVERLAP. SCALLOP OVERLAP BY MARKING 12 EQUIDISTANT POINTS (LIKE A CLOCKFACE) AROUND CIRCUMFERENCE OF OVERLAP. DRAW ON SCALLOP CURVES, AND CUT.

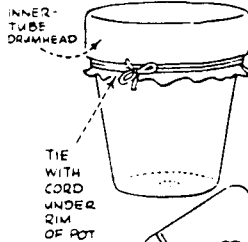

MADE FROM A LARGE CLAY FLOWER (PLANT) POT. THIS DRUM'S INSPIRED BY THE EARTHENWARE DRUMS FOUND IN MANY PARTS OF AFRICA. PLAY IT WITH THE FINGERS, OR WITH DRUMSTICKS.

A SMALL, LIGHT PLASTIC JERRYCAN...



LIKE THIS ... MAKES A FIRST CLASS FINGER-DRUM. SO DOES A LARGE PLASTIC BLEACH BOTTLE!

Drums

There are many different kinds of drums, and the sound you achieve will depend on the size of the object you use as a base for your drum, and the type of drum head you choose. You can use almost anything cans, containers, oil drums or even old pots and pans. Rubber inner tube makes an excellent drum head, and this can be stretched over the base, and tacked or laced on to the drum.

String Instruments

Pride of place in this section must go to the tea chest bass. If a tea chest is unattainable then a 20 litre oil drum can also be used. Apart from the tea chest or oil drum, you will need a broom handle and a piece of string.

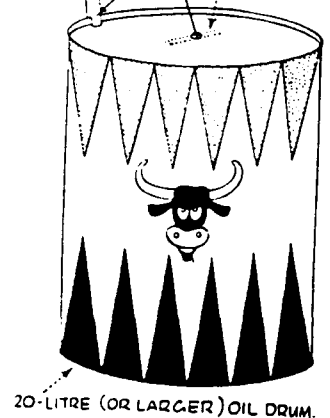
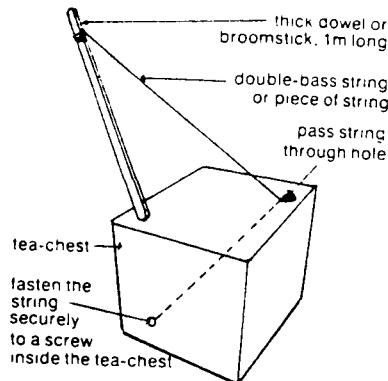
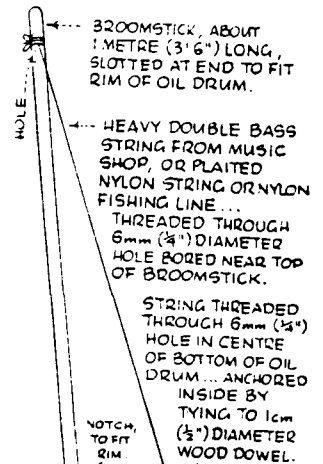

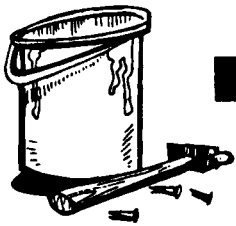

Shadow Puppets

Shadow puppets are thought to have originated in China, moved on to Asia, Turkey and Greece. They were particularly popular in Europe during the eighteenth and nineteenth centuries. Lit from behind, shadows would be projected on to a screen. The puppets themselves were made out of cardboard which were moved on rods. It is also possible to create shadow puppets using your hands to make the shape of animals.

In order to start creating your shadows you will need a blank wall or screen and a light source which can either be a slide projector, a lamp or a candle. The shadows are then created by placing your hand in the shapes shown with the puppeteer shading between the light source and the screen.

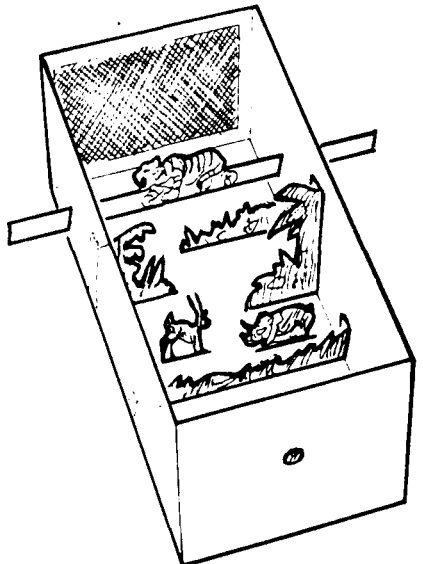
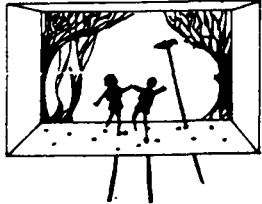
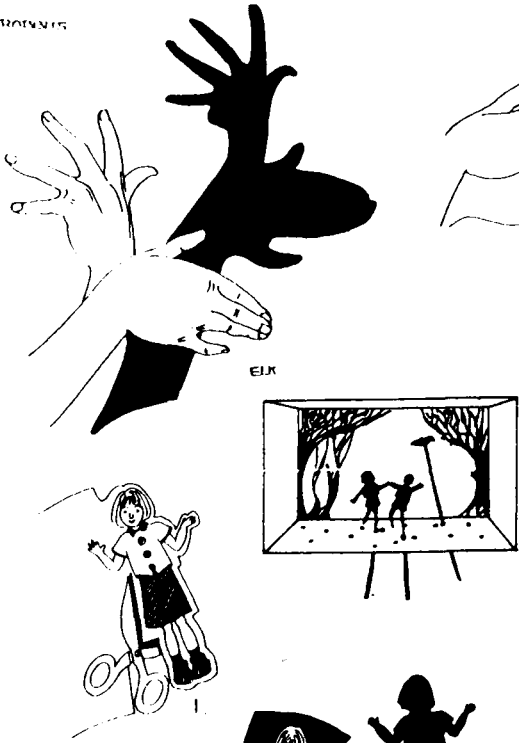
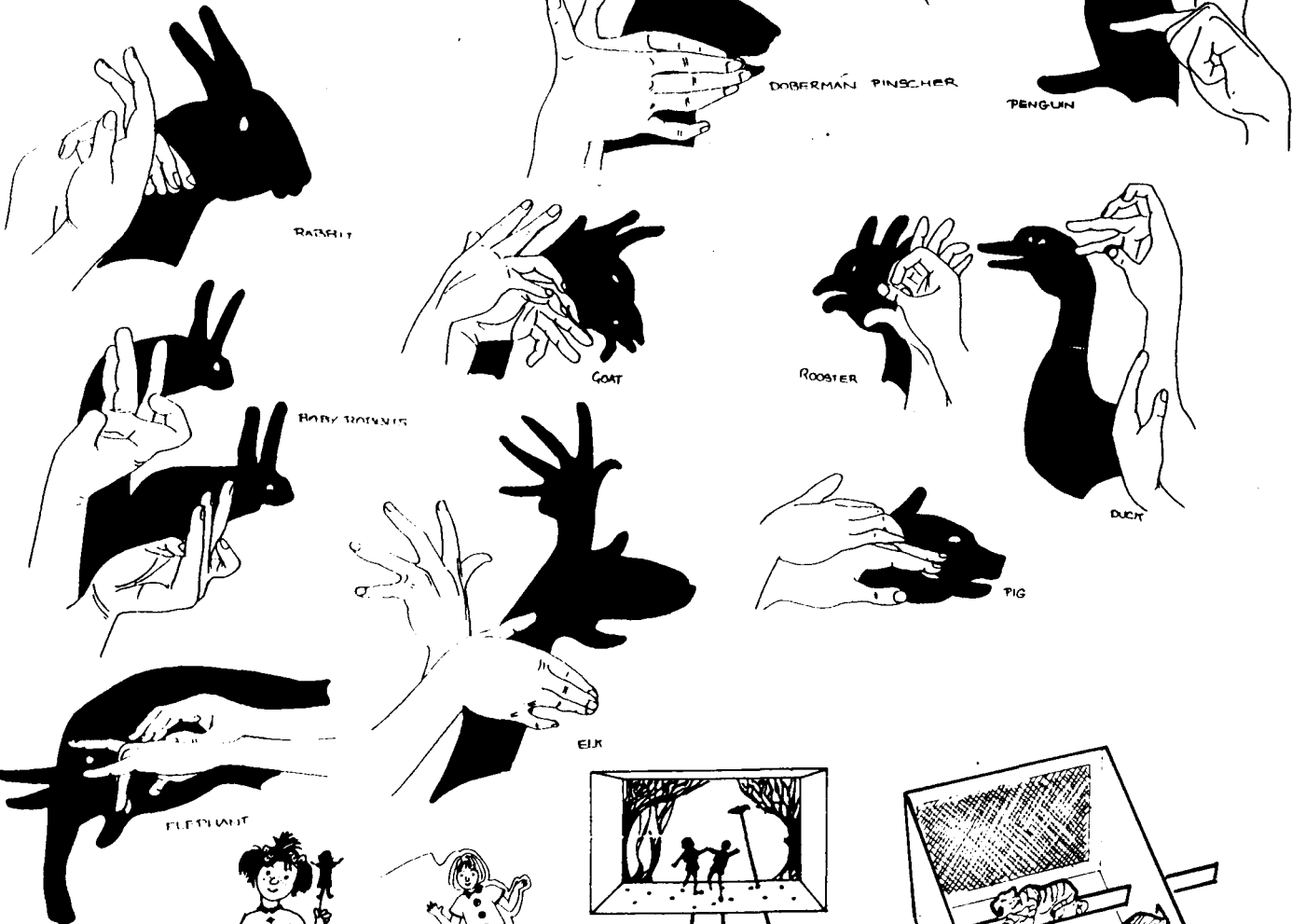
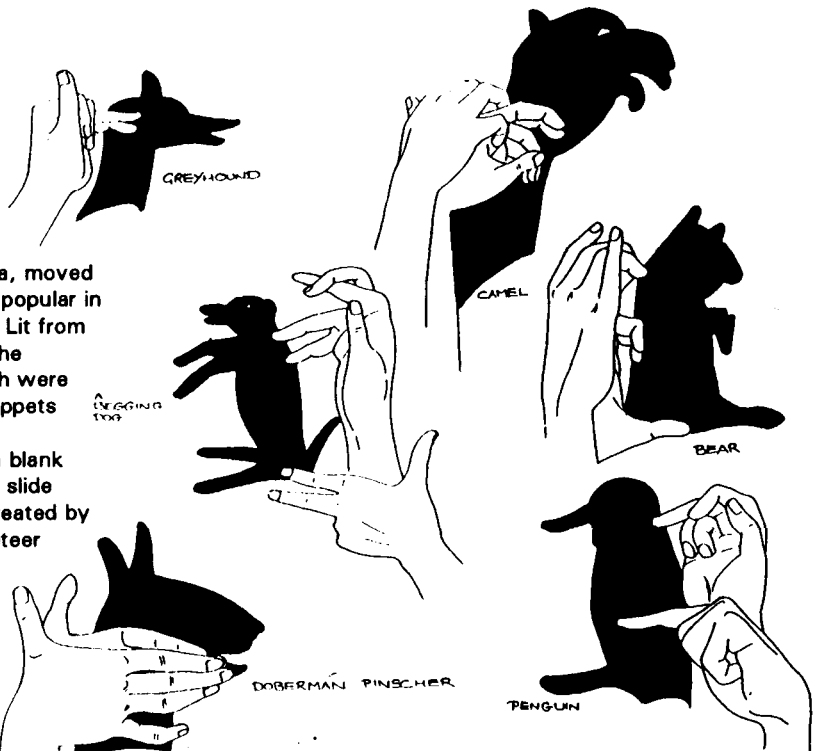

Cut out puppets

These puppets are made by collecting pictures from magazines and books and pasting these figures onto card. The figures are then cut out and painted black so creating silhouettes. A small stick is glued to the cut out so that it can be moved around the screen.



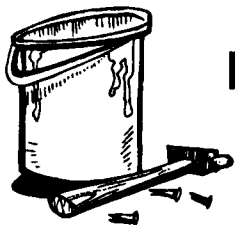

Putting on a shadow show

Once you have perfected hand shadows and cut outs, you may want to do something more daring. Because shadows are flat you can do unusual things behind the screen. For example in the illustration a surgeon is taking a variety of different objects from a victims stomach. You can also change the profile of your body by attaching props and cardboard cut outs to your body.

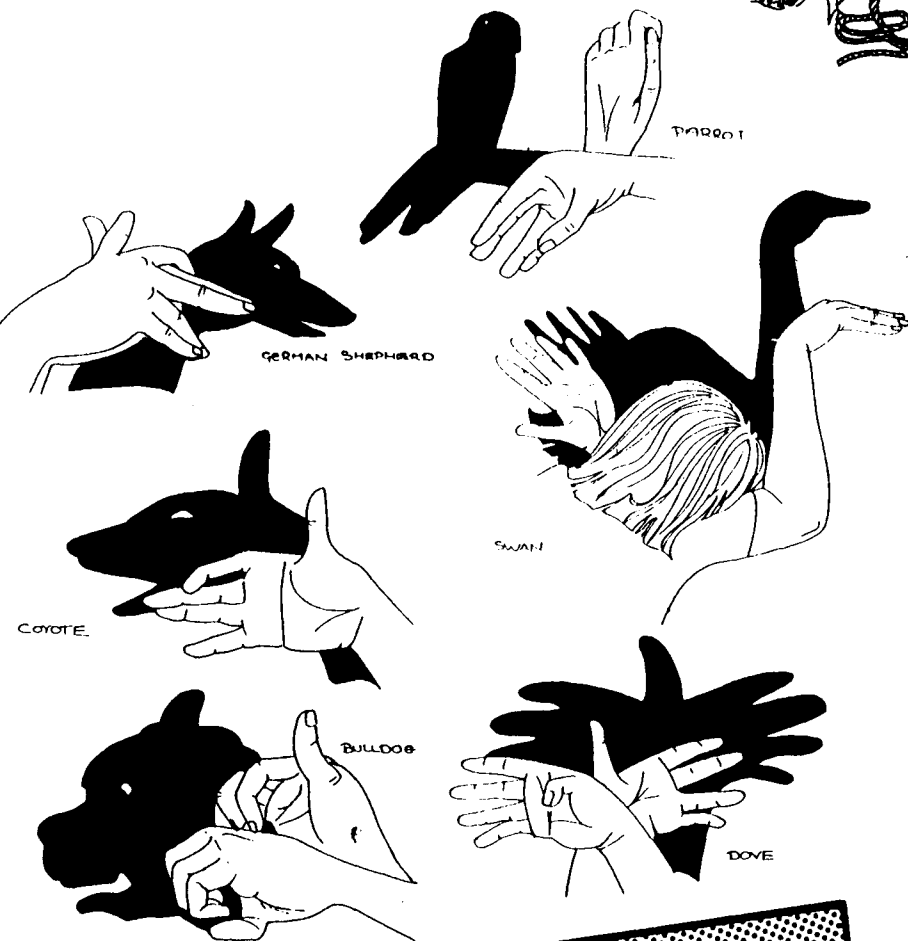

Special effects

When you put on a show it is useful to have interesting special effects to help build up the atmosphere and make the play and show become more real.

Rain

This sound is made by sprinkling uncooked rice on a baking tray. It sounds like rain on a window.

Flames

The sound of a fire may be made by crumpling up a ball of cellophane.

Thunder

Thunder is made by taking a large sheet of tin and shaking it violently backwards and forwards.

A change in weather

A change in weather effect can be achieved by using a dimmer switched light.

Ghostly effects

These can be done by using coloured light bulbs or by placing coloured cellophane in front of the bulbs.

Marching army

This sound is made by filling a tin with stones and shaking it up and down.

Horse's hooves

Two coconut halves or two empty paper cups and bringing them alternatively up and down on a table top.

Bird song

Find someone who is good at whistling and you will have no trouble reproducing a number of sounds.

Tape recording

If you have a tape recorder you can record any number of sounds from cars moving off to trains and police or ambulance sirens.

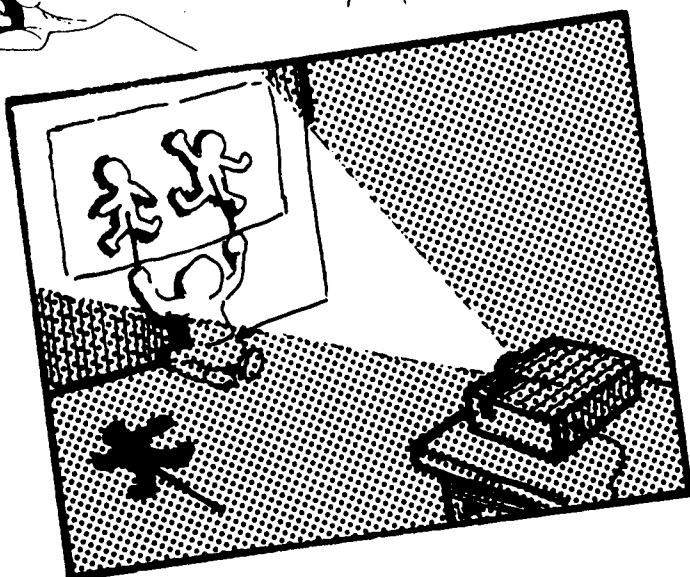

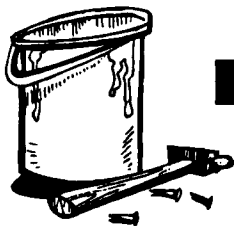

Indian Theme

Making a tepee

This tepee can be made using plastic sheeting or a piece of old canvan or bed sheets. If you are using plastic strengthen the holes with sticky tape or eyelets.

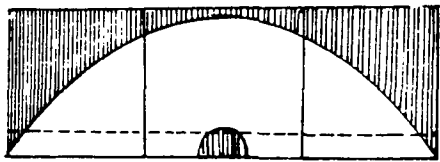

Sew or stick down a double hem so that holes can be made for fastening.



You can decorate your tepee with colourful Indian designs using cardboard stencils and spray paint in aerosol cans.

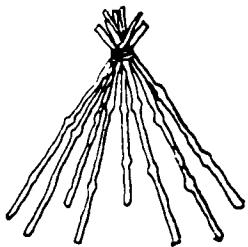

Use 8 long garden stakes and thick rubber bands for fastening them at the top

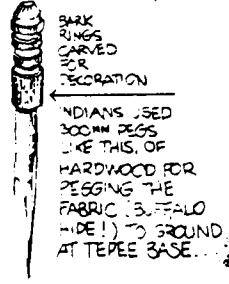
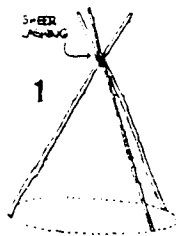

INDIANS USED BOON PEGS LIKE THIS, OF HARDWOOD FOR PEGGING THE FABRIC (BUFFALO HIDE!) TO GROUND AT TEPEE BASE...

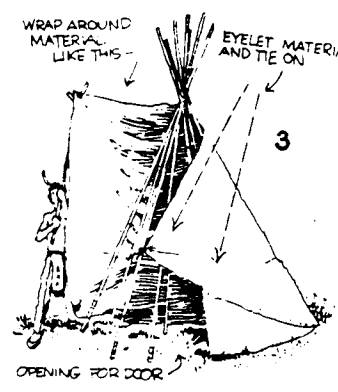
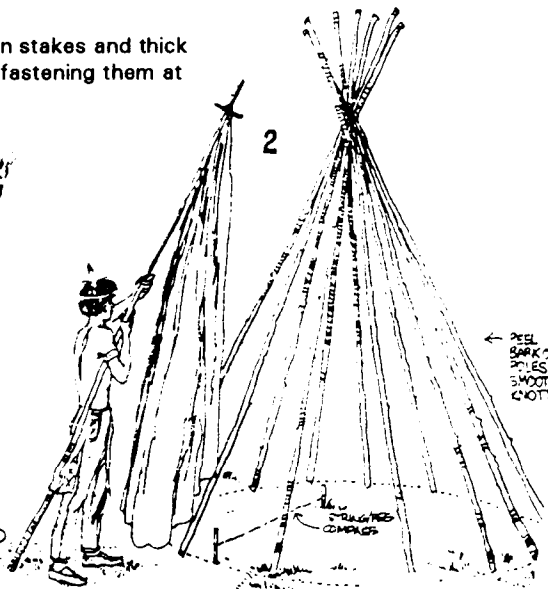

Indian dance steps



Hop step
This is a skipping step with a double hop on each foot. All dancing is done on the balls of the feet. The heels do not touch the ground at any time during the dance step. The knees are lifted high.



Stamp five toe step
one foot is brought down with a stamp and the other foot makes light taps, the number depends on the beat. On the loud beat the tapping foot stamps down, and the other foot becomes the tapper.



Toe heel step
Each foot is advanced so the toe just touches the ground. The heel is then brought down with force. The toe touches on the loud drum beat and the heel is brought down on the soft beat. Body motions may accompany this step

Wind stick

This noise maker was used by medicine men of the Apache, Ute, Navajo and Pueblo Indian to imitate the sound of wind. They hoped it would call rain clouds to bring rains to their dry lands.

To make one you need a piece of wood, 200mm by 75mm by 6mm; a 500mm piece of string, a dowel or piece of broom handle.

Trace or enlarge the design on the wood. Cut the design out and sandpaper all over. Paint as desired. Drill a hole in the top of the stick and tie the cord on to it, the other end of the cord is attached to the handle.

Now grasp the handle tightly and spin over your head.

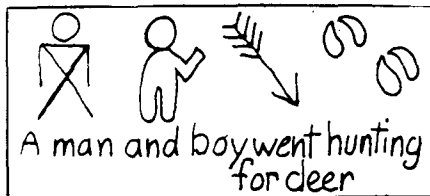
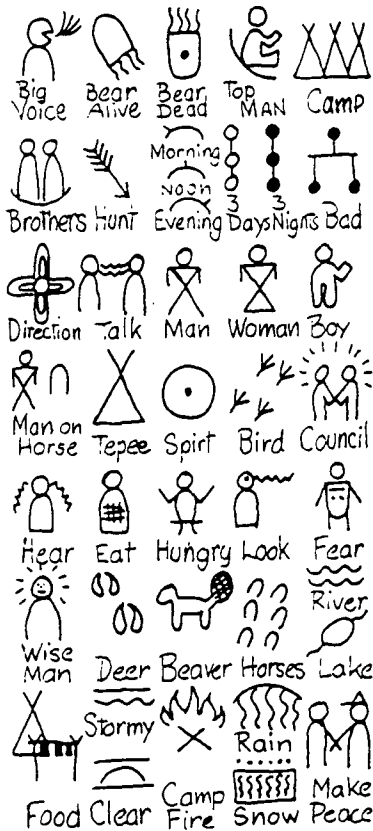

Breechcloth

Make the breechcloth about 25cm wide. The length is as long as the height of the wearer. it is worn slightly longer in the back than in the front. decorate it with Indian designs and markings.

Totem poles

Simple totem poles can be made out of old cardboard boxes, egg trays, yoghurt containers and other such materials and decorate them with paint and Indian signs. You can also use timber or perhaps aeroboard or coloured and varnished corrugated cardboard. Smaller Totem poles can also be carved out of balsa wood or candles.



CARDBOARD HEAD BAND

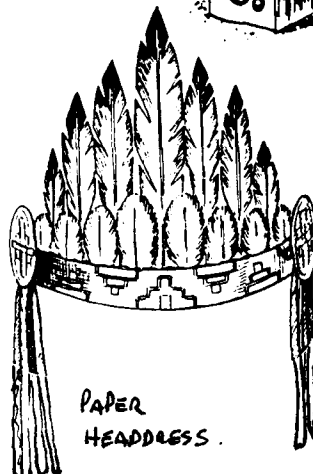
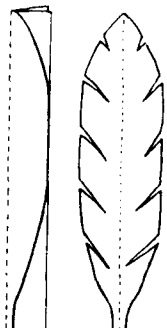

PAPER HEADDRESS

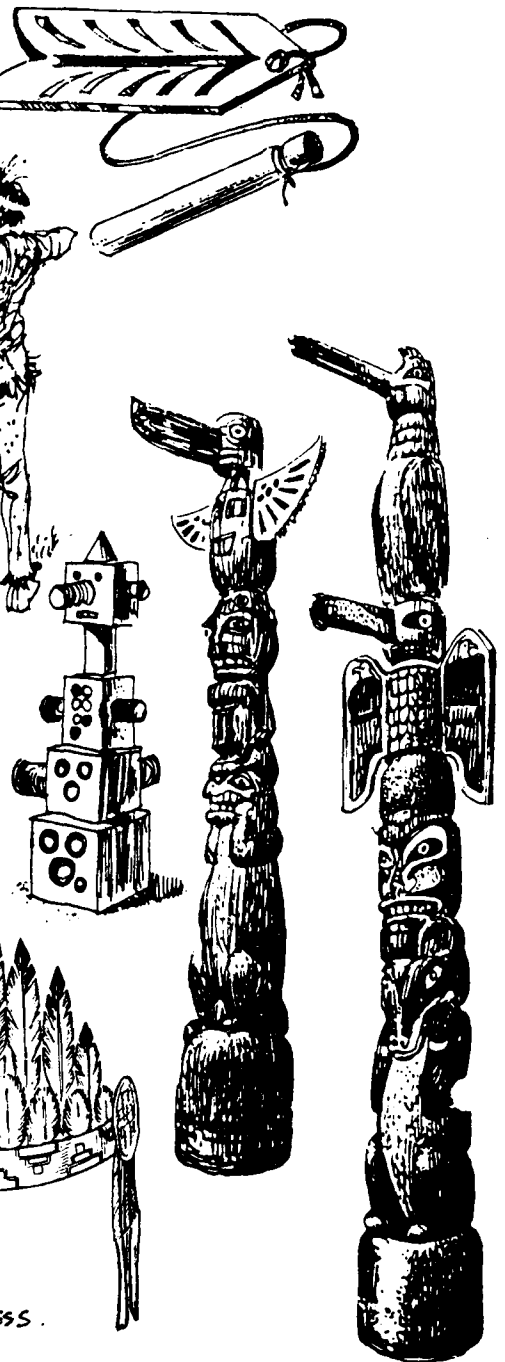

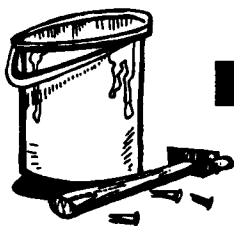

Kites

Kites have always fascinated young people. All that is needed on top of enthusiasm is a little wind and your kite is flying.

We illustrate a number of simply kites for your Beavers and Cubs to try. You will need some stiff card, plastic bags, some light canes (split cane can be brought from garden centres), some staples and glue, and a cutting knife.

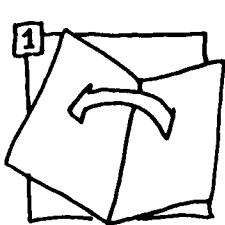
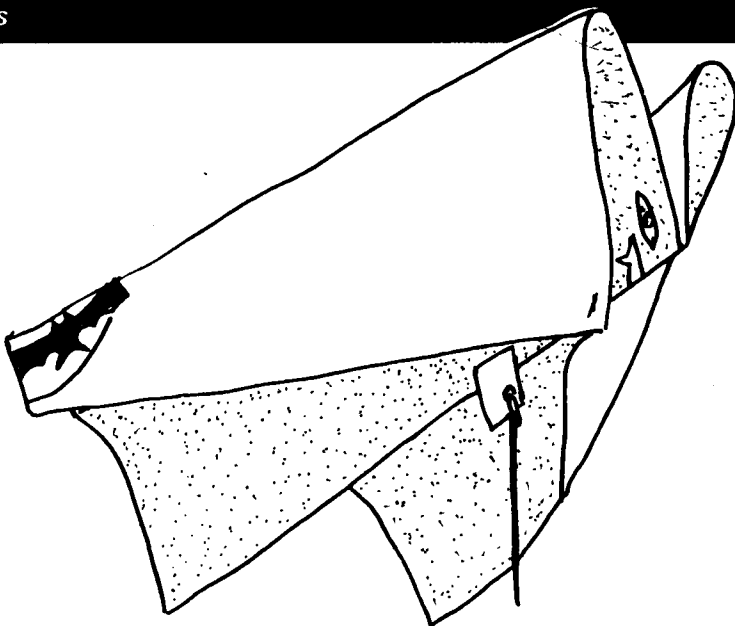

1 Take a sheet of A3 paper (420 mm x 297 mm), and carefully fold it across the middle as shown above.



2 Pull one side of the sheet round in a curve. Staple it against the centre fold, 35 mm from the tip.

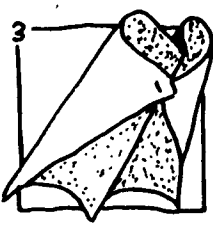

3 Repeat on the other side. Make sure the corners slightly overlap the centre fold, as shown above.

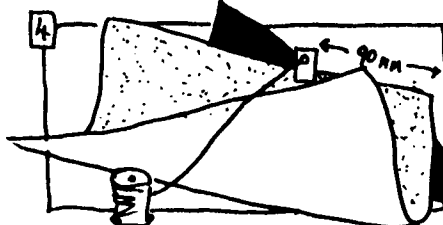

4 Dracula's Cloak doesn't need a bridle ring. Just stick a square cut from thick tape to the centre fold, 90 mm from the

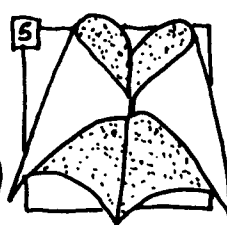

tip. Make a hole through the tape as shown in the picture, either with a hole puncher or a pair of scissors.

5 Use lightweight thread to fly the Cloak. It will rise in the lightest breeze, and hover menacingly above you!

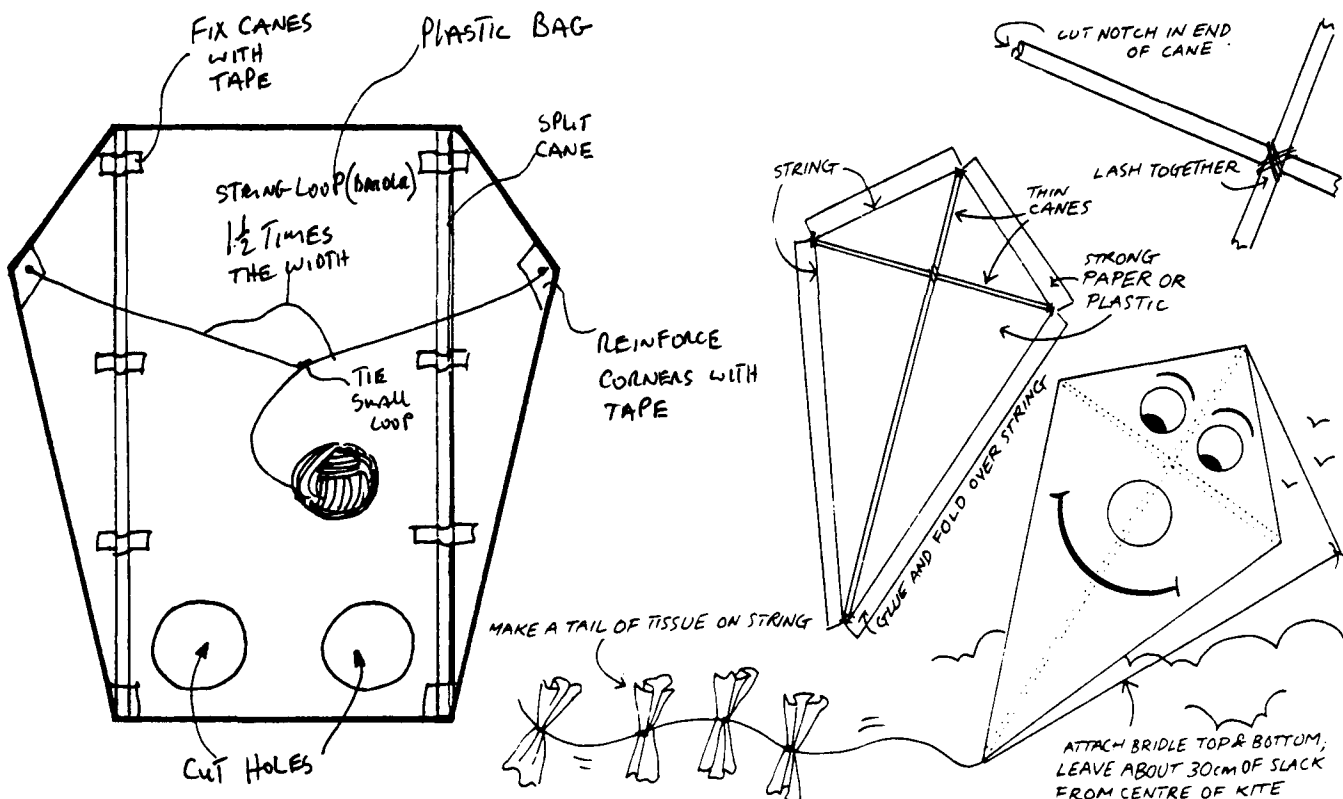

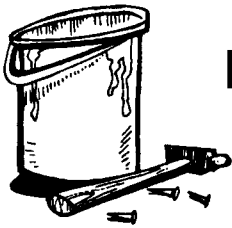

Christmas Crafts

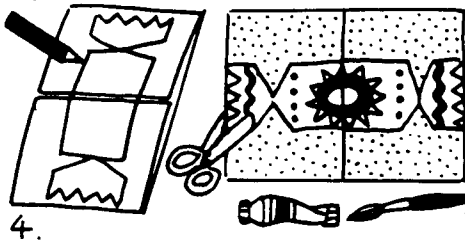
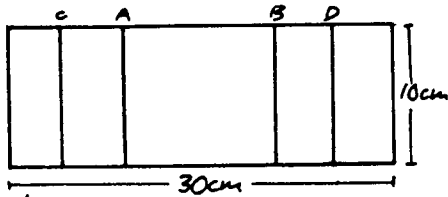
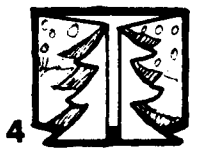
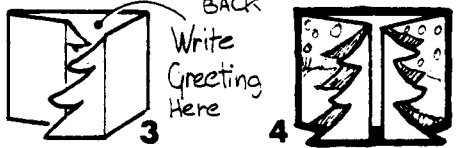
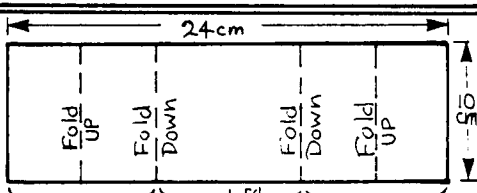
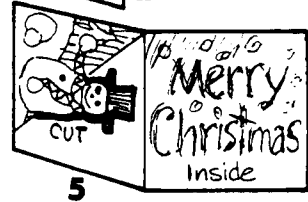
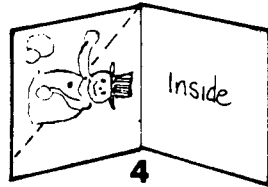
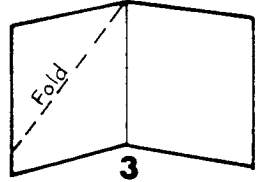
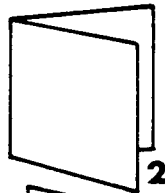
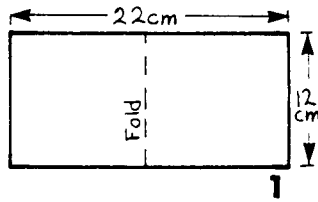

5, 6

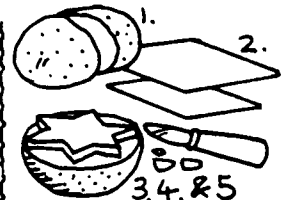
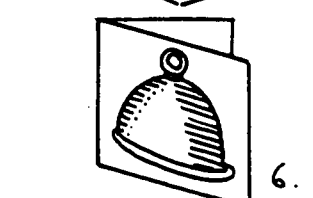
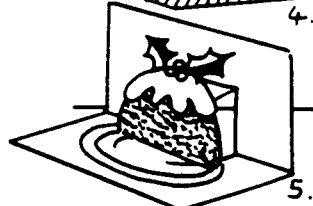
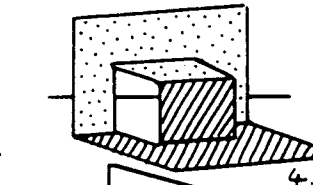
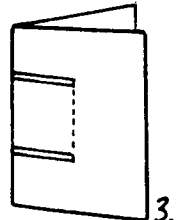
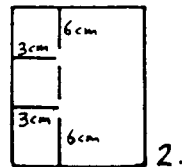
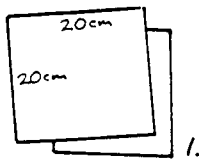
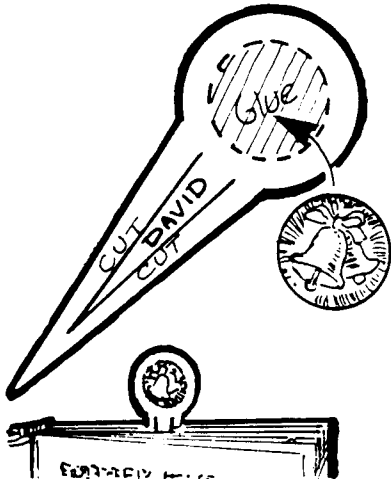
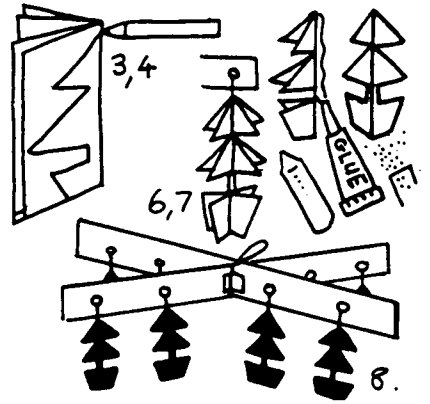
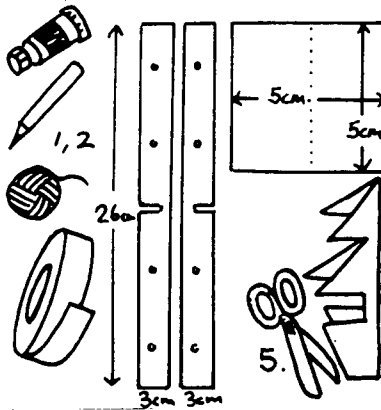
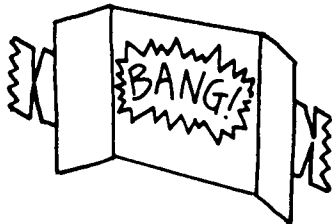
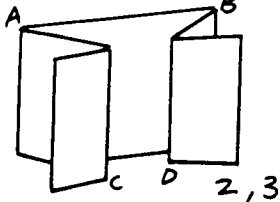

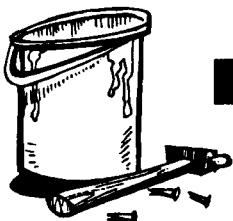

Knights

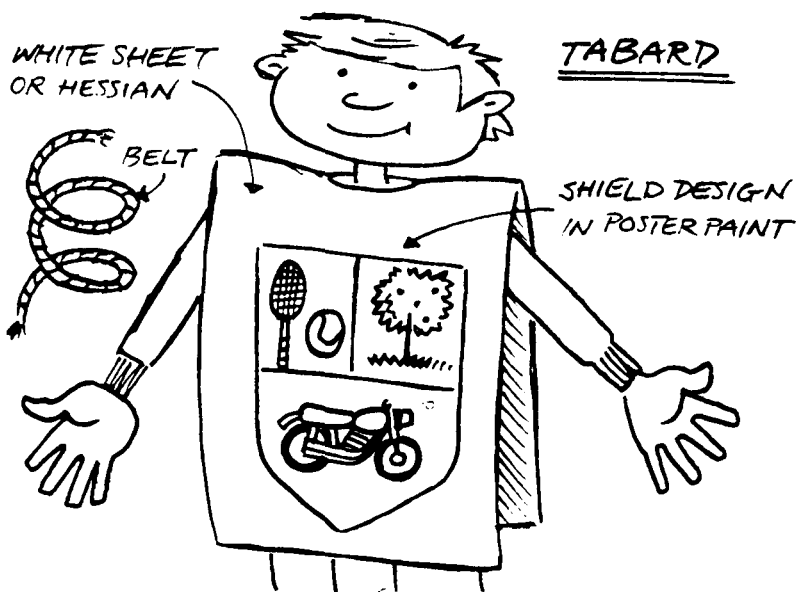

SHIELD SHAPES

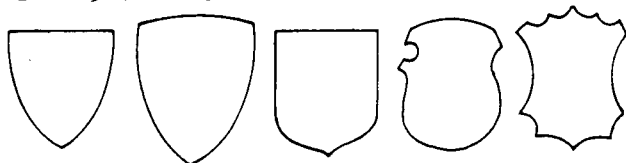

SHIELD DIVISION 1

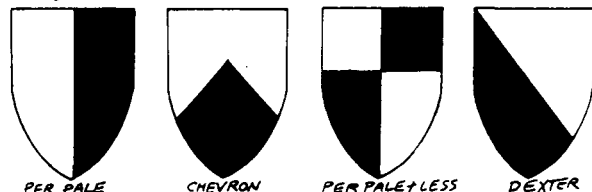

SHIELD DIVISION 2

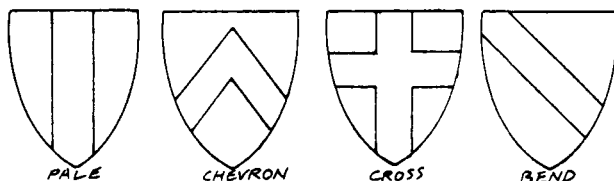

BADGE DESIGNS



PATTERNS

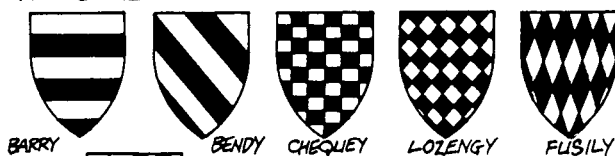

The Knighting Ceremony

At the end of your meeting/ activity don't forget to knight your Cub Scouts. Use the Knight's Code in the ceremony, a code on which the Scout Law is based.

Be always ready with your armour on, except when you are taking your rest at night.

At whatever you are working at try to win honour and a name for honesty.

Defend the poor and weak

Help those you cannot defend themselves

Do nothing to hurt or offend anyone else

Be prepared to fight to defend your country

Work for honour rather than profit

Never break your promise

Chivalry requireth that youth should be trained to perform the most labourious and humble offices with cheerfulness and grace.

Do good onto others.

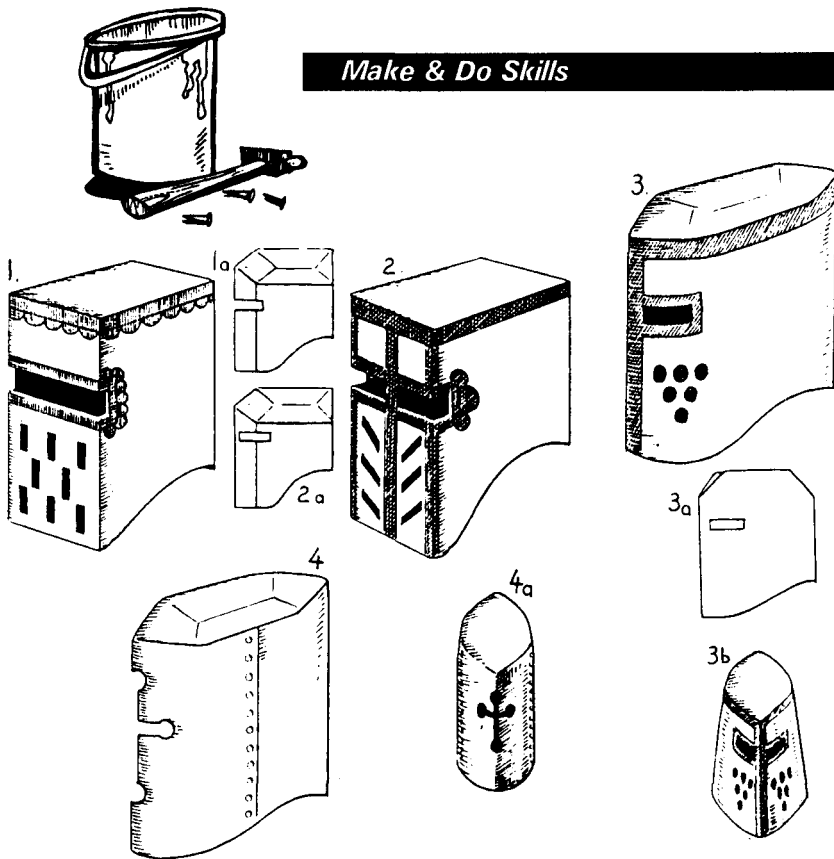

● INDOOR JOUSTING

DESIGN AND BUILD YOUR OWN APPARATUS. IN THIS MOCK-UP, BAMBOO, SISAL TWINE, INSULATION TAPE, PLYWOOD BOARDS, AN OLD BOXING GLOVE AND A BUCKET OF EARTH HAVE BEEN USED.

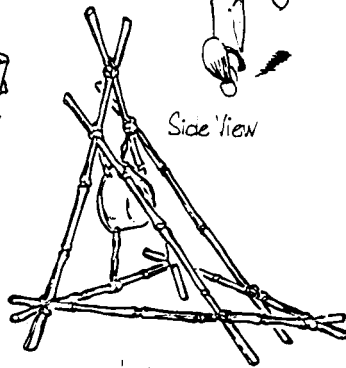
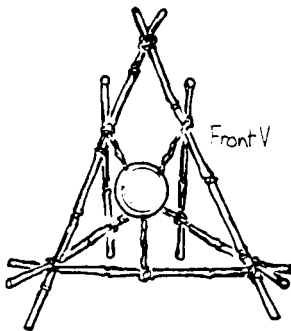
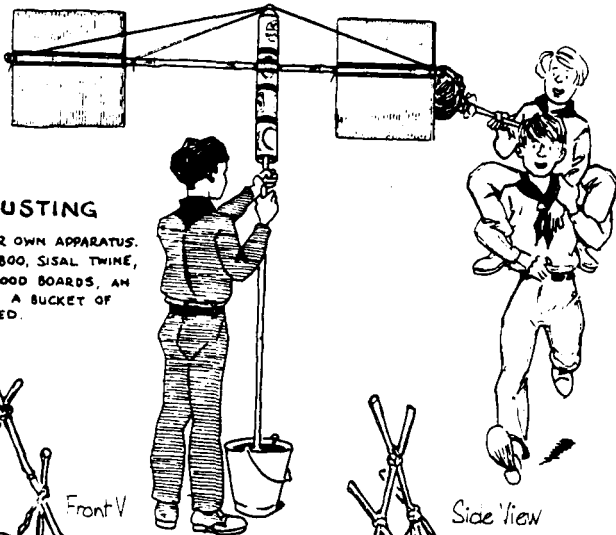

Fasten all three elastic bands around the margarine pot.

Becoming a Knight

Before a boy could become a knight he had to serve a long apprenticeship in the skills of horsemanship, fighting and chivalry before he was able to win his spurs and become fully fledged knight. During the apprenticeship, he would act as a page to an experienced knight, looking after the horse and equipment. When a boy was ready to become a knight he was set a number of challenges to prepare him for the problems he will face. Here are a number of challenges to set your 'Knights' once they have made their costumes so that they can gain their knighthood.

Follow the trail of the dragon

Let the Cub scouts follow a trail of dragon slime. The slime can be made by shredding some soap into a pot and boiling it with a little water. The soap should dissolve they go slimy as the water evaporates away. Daub the slime along a trail in patches from the Cub scouts to follow. At the end of the trail construct a sleeping dragon from cartons and cardboard boxes for the would be knights to slain.

Climbing Rapunzel's hair.

Rapunzel was a maiden who was kept locked away in a tall tower. She was rescued from the tower by lowering her long hair out of the window for a knight to climb up. Set a rope up a tree with a leader at the top of it dressed as Rapunzel. The brave knight must climb the rope and collect their reward - a chocolate gold coin.

The sword in the stone

The story of King Arthur tells of a sword which was fixed in a magical stone and it was said that who ever removed it from the stone would be the next King. Many people tried but failed. Arthur then a young boy was the only person who could remove the sword. Drive a large wooden peg into the ground. The peg maybe disguised as a sword and see if any of our brave knights can remove it without breaking it.

Looking after the armour

All apprentices had the task of polishing their master's armour. Give your 'knights' instructions on how to shine up some brass and let them try their hand at cleaning a brass ornament.

Dragon's eyes

Roasting dragon's eyes - toast marshmallows on a stick over a fire

Jousting practice

Construct the jousting apparatus as shown.

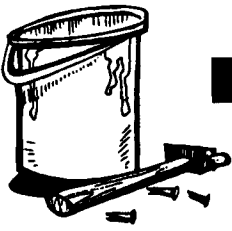

Masks

Most of the masks illustrated have been designed to be simple enough for young people to make by themselves. The slightly more difficult ones will need the help of an older person.

The most important materials you will need are large paper bags and white or coloured paper plates. The bags can be of any variety - plain brown, coloured, patterned or printed with words, and with or without gussets. As far as possible, the masks and hats can be made from materials found around every house. To decorate your masks you will need paints (to cover up all unwanted patterns or words on the bags), a few sheets of coloured paper, and glue.

Before you cut a bag, make sure it is the right size by fitting it over the head of the wearer. Start by putting down newspaper or some other protective covering over your working surface. Then gather together all the materials you need to make your mask. Have a damp cloth handy for sticky or paint covered fingers.

Materials

Paint
To cover up unwanted letters and words on bags you will need to use paints with a bit of 'body'. Use poster, acrylic, emulsion or aerosol spray. If the mask need two coats of paint let the first coat dry before you apply the second.

Glue
A 'Pritt Stick' is ideal for the making of masks as it is less messy than other glues. 'Bostick' may need to be used on heavier cardboard.

Paper
Cartridge and poster papers can be brought in a wide variety of colours. Use them whenever possible for ears, hair, noses etc., as they will save you having to paint.

MASKS. ROBOT AND DRAGON

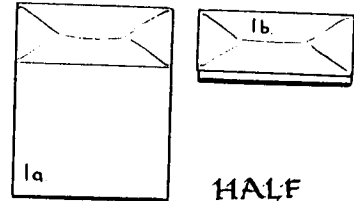
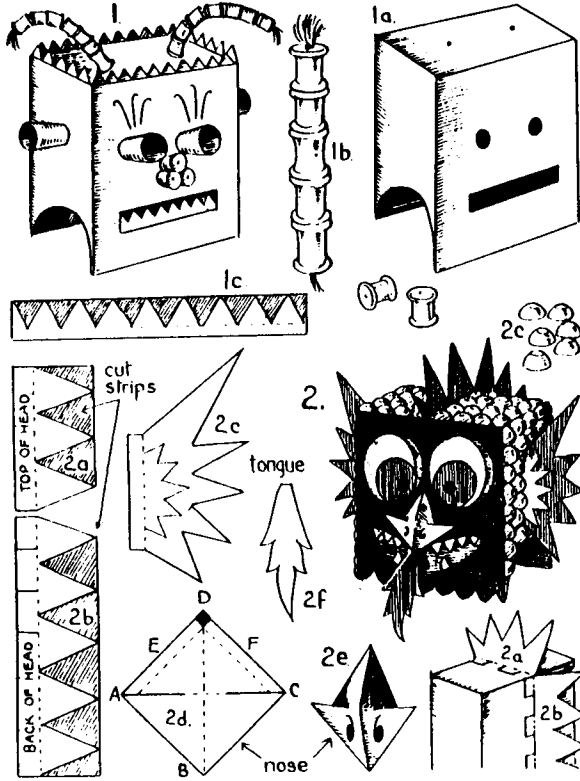

HALF MASKS

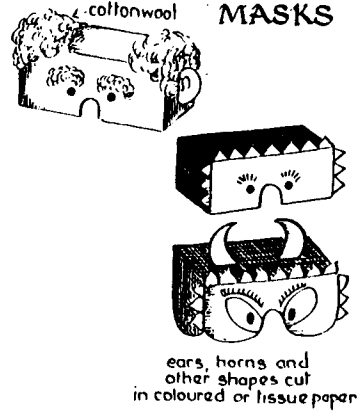

ears, horns and other shapes cut in coloured or tissue paper

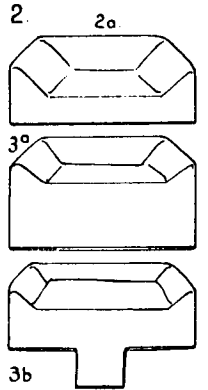

MASKS FROM PAPER PLATES

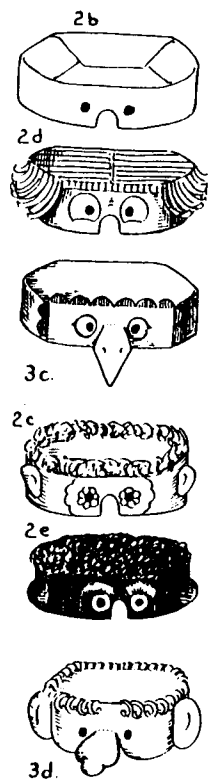
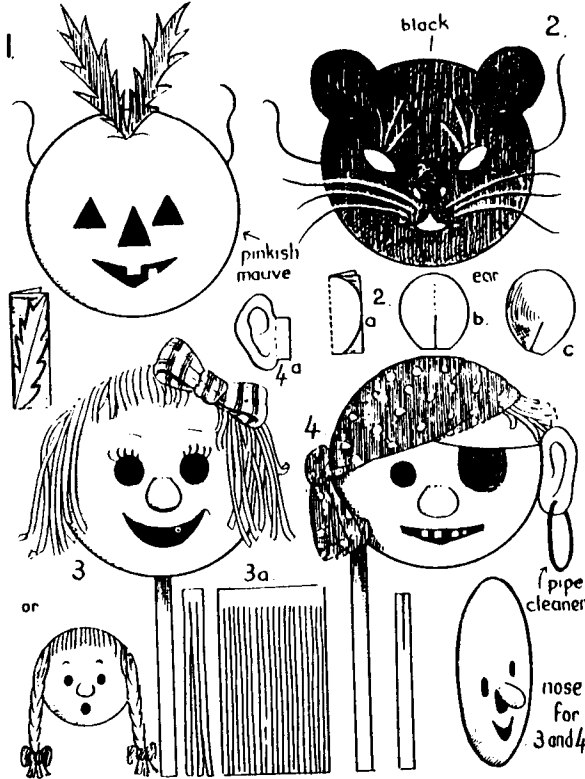

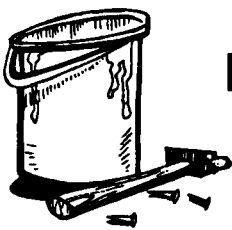

OWL AND MOUSE MASKS

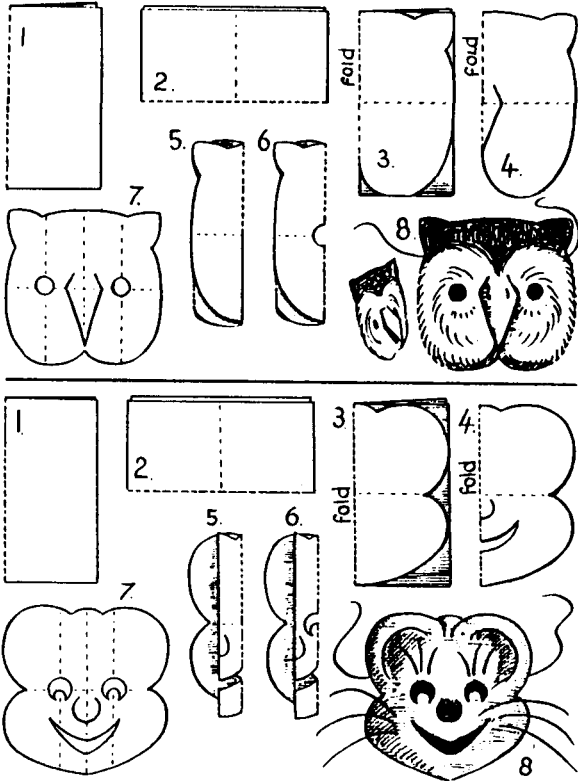

FOUR FACE MASKS

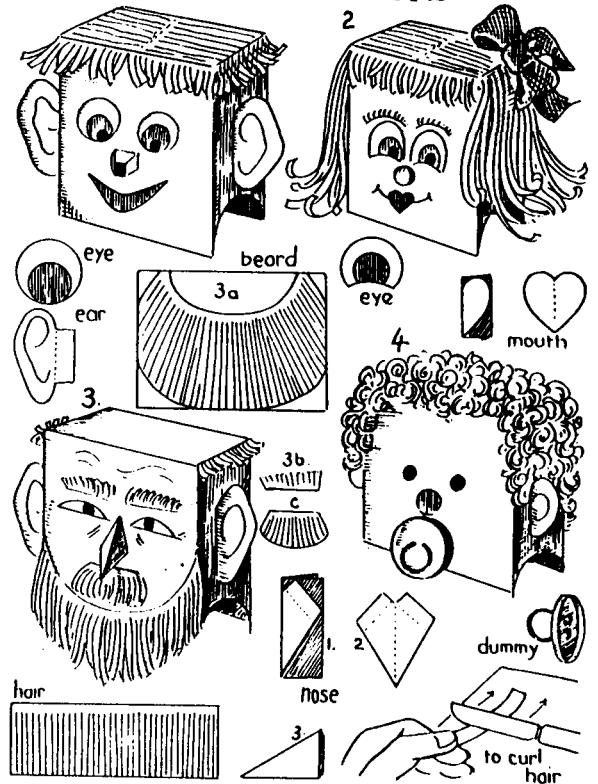

OWL AND LION MASKS

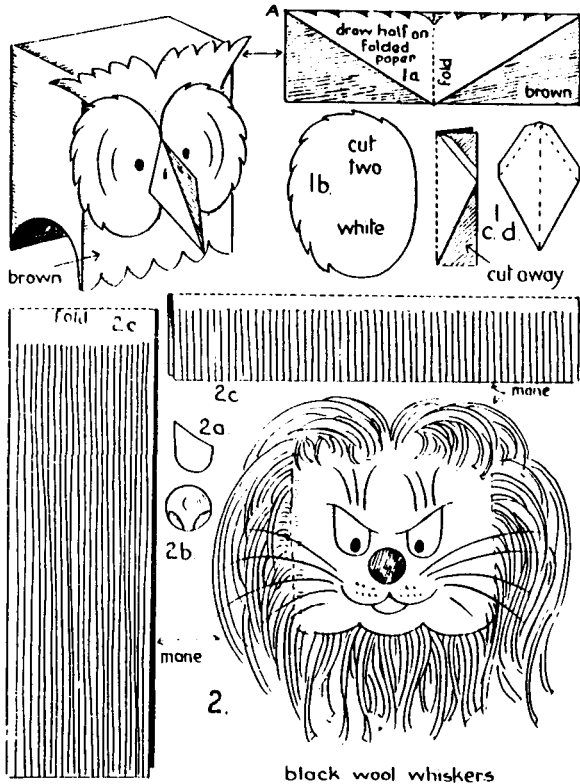

HALF MASKS FROM PAPER

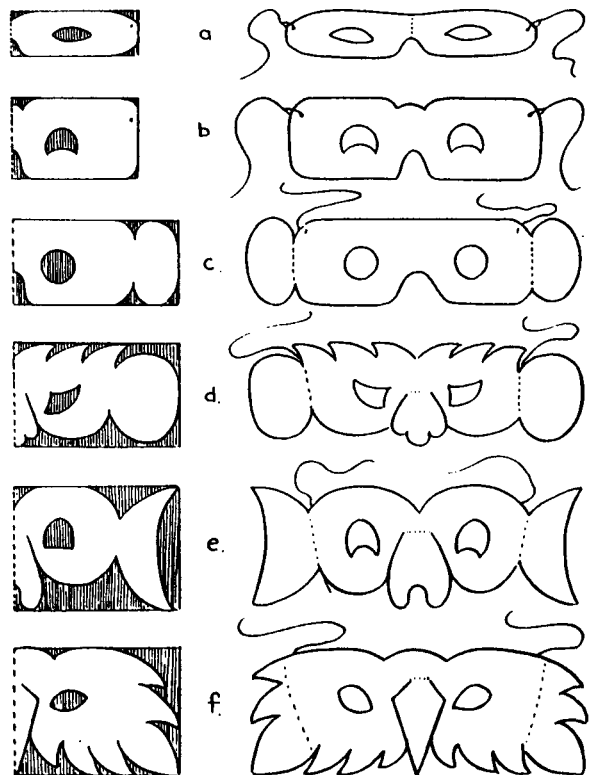

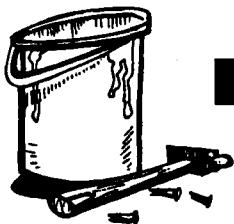

Funfairs

It is possible to set up a fun fair with your Pack or Colony. This might be used for fundraising or perhaps as part of a bring a pal day or activity. Some simple ideas for you to make.

Jars in the pool

A paddling pool full of water and several jam jars. The jam jars are submerged in water. Players are invited to try to get a coin into any one of the jars by throwing them from behind a line on the floor/ground.

The stocks

Construct a stocks into which some unlucky Scout or Leader is put and wet sponges are thrown at him/her. To make the challenge harder construct a garden cane ballister. The canes are held together with rubber bands.

Guess the toy bricks

Cubs/Beavers have to make a model out of building blocks. You can then use them for guessing how many piece of Lego have been used or deciding what the are.

Treasure map

Get your Cubs/Beavers to make a landscape out of paper mache or modeling clay. Include mountains, lakes, and caves, in fact let the imagination wander. Use the model at your funfair and ask people to guess the location of the treasure by pushing cocktail stick flags into it.

Test of strength

Construct the testing devise as shown. To test ones strength you simply grip the bottle with one hand and squeeze as tightly as you can.

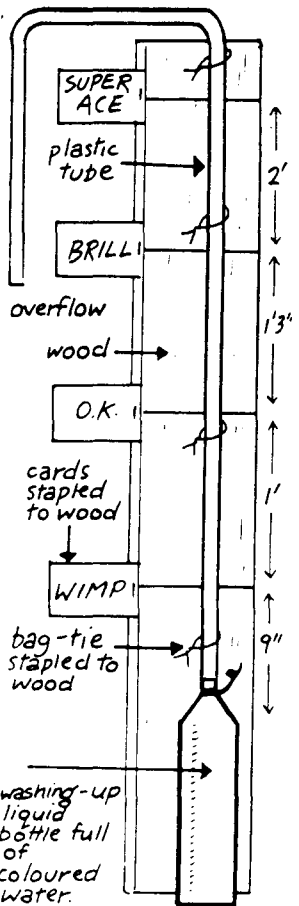
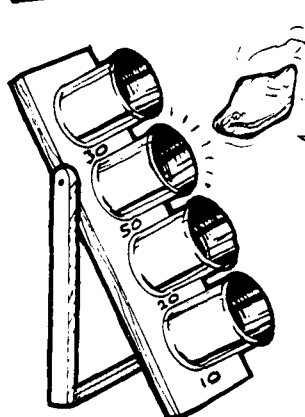
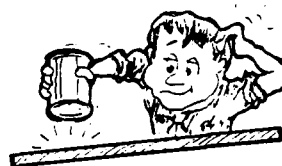
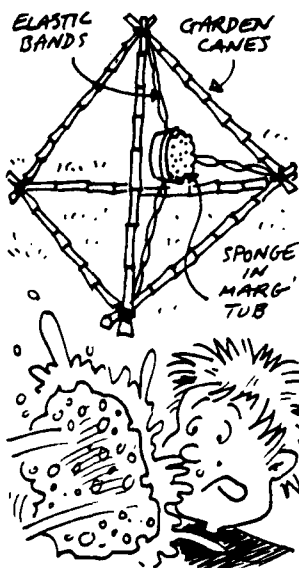

Bean bag bung

You will need a plank and a few tin cans. The cans are fixed to the plank by nailing to the plank or by drilling and screwing. Each can is painted and given a number of points. Players try and throw bean bags into the tins from a set distance.

Dock a flying saucer

Collect a number of shoe boxes and paint them the same colour. Draw a score inside each box as shown. The boxes are then glued together to form a double column. Flying saucers are then made by stapling two paper plates together. Player are asked to dock their saucers in the docking bay. The only thing you have to check is to be sure your plates are of the right size so that they fit into the bay easily.

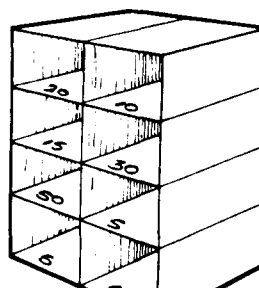

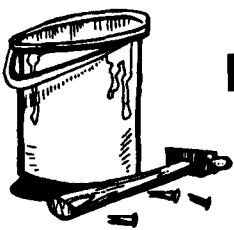

Photography

Camera less photography

Approximately £10 will give a pack a fascinating activity - taking photographs without a camera!

You will need to buy:

- 1 No. bottle of developer (125ml)
- 1 No. Bottle fixer (125ml)
- 1 No. Packet printing paper (25 sheets - postcard size)

You can buy bigger sizes in paper and cut them down if you like but this must be done in safelight conditions.

You'll need to borrow

(perhaps from a photographer - who may even assist you on the activity)

- A safelight
- An angle poise lamp
- A sheet of glass
- 4 dishes (large enough to hold a postcard)
- A Pair of tweezers
- A thermometer
- A measuring jug

When you buy the developer, state that you want it for developing paper

Warning - Do NOT open the packet of paper unless you are (a) in total darkness or (b) using the red safelight as the only form of illumination. If you open it in ordinary light it will be ruined.

Plug in your red safelight, or alternatively put a red bulb into the room light socket

(its cheaper). Make sure all the windows are blacked out, assemble your Pack in the room, and lock the door, leaving the key inside - this is to prevent someone barging in at the crucial moment. Lay out the four dishes on the table in the order shown. In dishes 2 and 4 used for washing purposes you want water. Dish 1 contains the developer (this

under the sheet of glass to keep it flat, shiny side up. Place the keys on top of the glass over the sheet of paper, switch on the angle poise lamp for 1 - 2 seconds and switch it off. The photograph is now ready to be developed.

Take the print and place it in the developer tray and move the developer

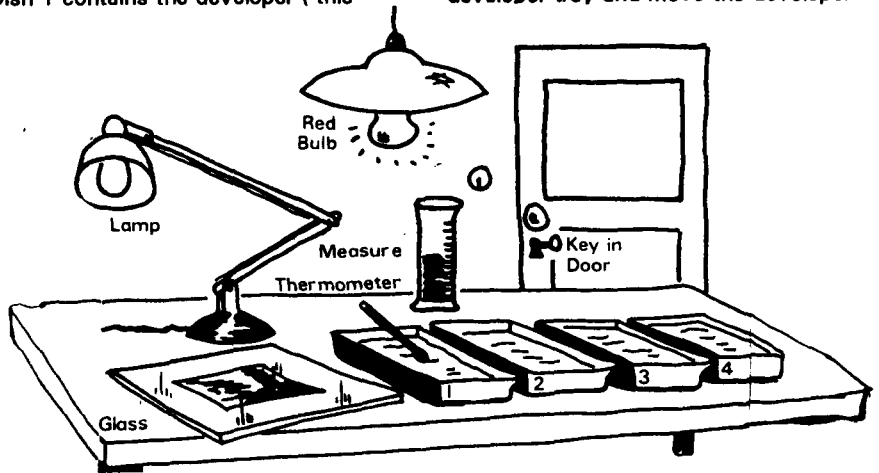

should be mixed according to the instructions) You need enough developer in the dish to cover the print to a depth of 2 - 3 cms

over the print until the print appears. Then quickly wash it in dish 2, and put it into dish 3, the fixer. This immediately stops the developer working. It is now safe to turn on the lights and examine your print. Finally wash it in dish 4. You may have to wash it under running water to remove all the fixer.

Action

Appoint someone to be in charge of the paper. His job is to make sure that the packet is kept closed in white light. If you want to 'photograph' a bunch of keys, under the red light's illumination take one piece of printing paper and lay it

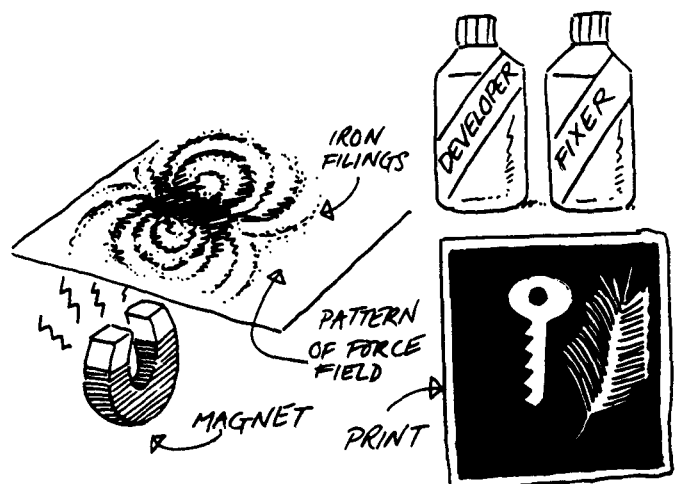
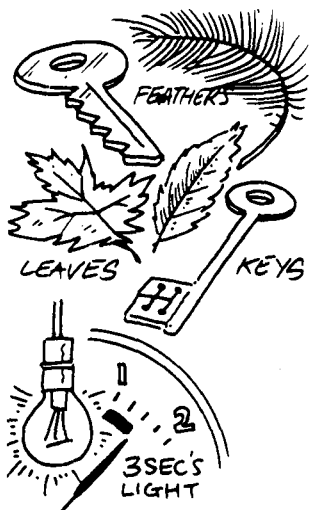

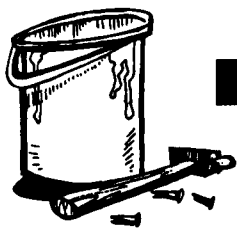

Woggles

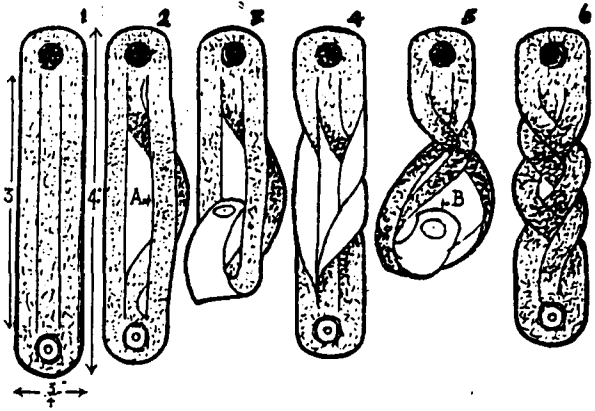

Making or re-plaiting a plaited woggle

Many of us have unplaited one of these woggles at some time or other in our scouting lives and then played for hours trying to get it back together again. Well, here the secret is revealed. You can of course make a new woggle by using a strip of leather and cutting slits in it as shown, and make your own woggle

- In each diagram the shaded area indicated the front of the woggle.
1. Fold the centre strip behind the right strip
2. Pass the bottom from the front through the gap marked A
3. You now have a weird looking plait as in diagram 4.
4. Make another plait as shown in diagram 5 and again pass the bottom from the front through the gap marked B
5. Straighten up the completed plait and your woggle is complete or fixed.

Turks head woggle

Method 1

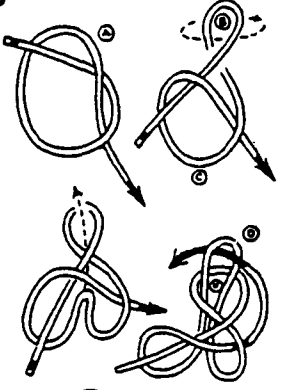
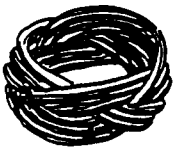

Method 2

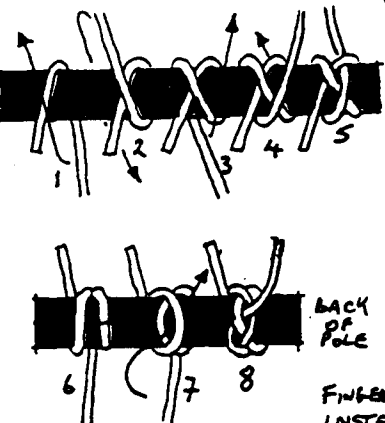

FOLLOW PATTERN WITH LEADING END TO 3 or 4 STRANDS TO COMPLETE WGGLE.

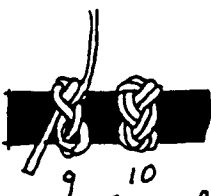

FOLLOW PATTERN TO COMPLETE 3 or 4 FOUR PLAIT.

FINGERS MAY ALSO BE USED INSTEAD OF POLE.

Indian Plaque Woggle

These eye catching designs from American Indians make for interesting woggles. Cut the disks from quarter inch piece of dowel and sand lightly to smooth rough edges. Paint the disk at least twice with white paint (undercoat and finish). Transfer the design to the piece of wood using carbon paper and paint on design with modellers paint.

- Colour Code**
- Corn dancer - Background white; headdress; yellow and red triangles; shirt black lines and black dots; feet- red dots; hands- yellow for corn, green for melons, blue and red for thunder and lightning.
 - Sunburst - Brown or blue triangles
 - Thunderbird - White background and brown or blue centre; bird - yellow; feet and beak - gold;

When dry apply a coat of clear varnish for protection. Glue a leather, wire or aluminum loop on the back, using epoxy glue.

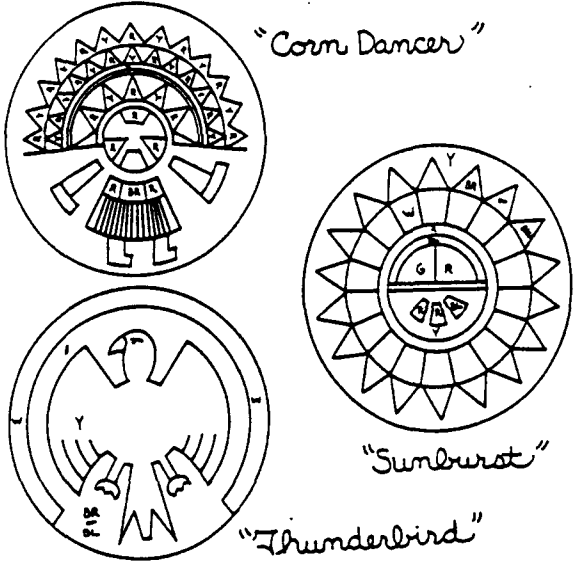

Carve an apple woggle

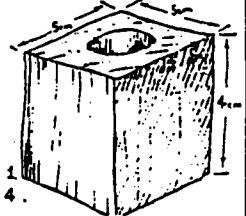

Prepare a piece of wood as shown in diagram 1, and then carve as shown in stages 2, 3, 4. Carve the worm as well, drill a small hole and glue into finished woggle.