

# On the move



# Navigation

Travelling through wild countryside is achieved by the use of a map and a compass. The map conveys a detailed picture of the landscape and terrain, the compass provides us with a tool that will steer us in the correct direction.

The secret of good navigation is a good knowledge of map reading and interpretation. The compass, although important, is secondary to good map reading skills.

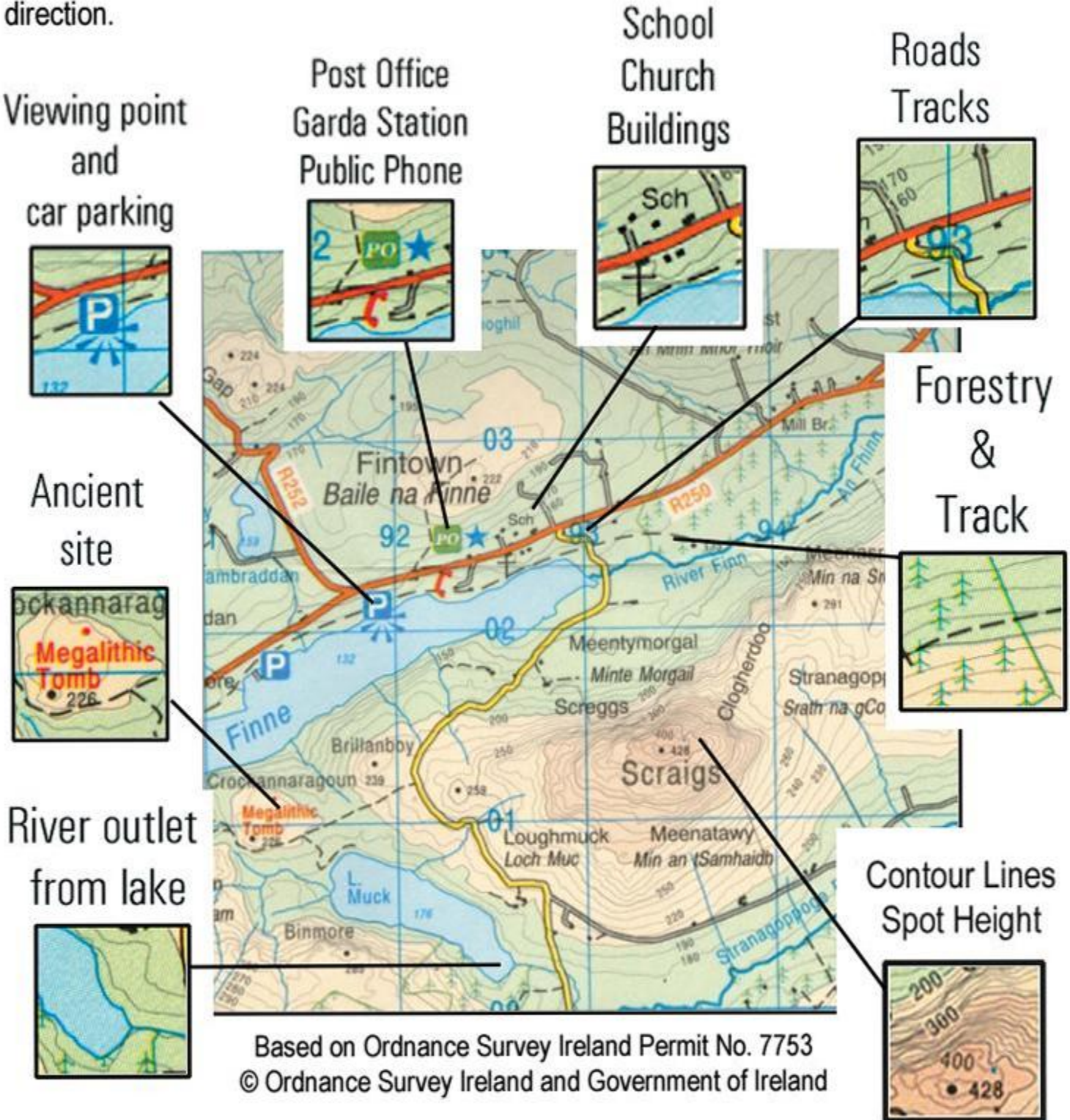

Based on Ordnance Survey Ireland Permit No. 7753  
© Ordnance Survey Ireland and Government of Ireland

ON THE MOVE

## Understanding your map

The map is a representation of the landscape. It is produced from satellite pictures and on the ground surveying. The map however is only two dimensional so it must employ a method known as contouring to show the rises and falls of the landscape. A number of symbols are also used to establish such features as forests, churches, boggy ground, fences, train tracks etc. Roads and tracks are marked on the map using a number of different coloured lines such as broken lines and checkered lines. Rivers and lakes are marked in blue.

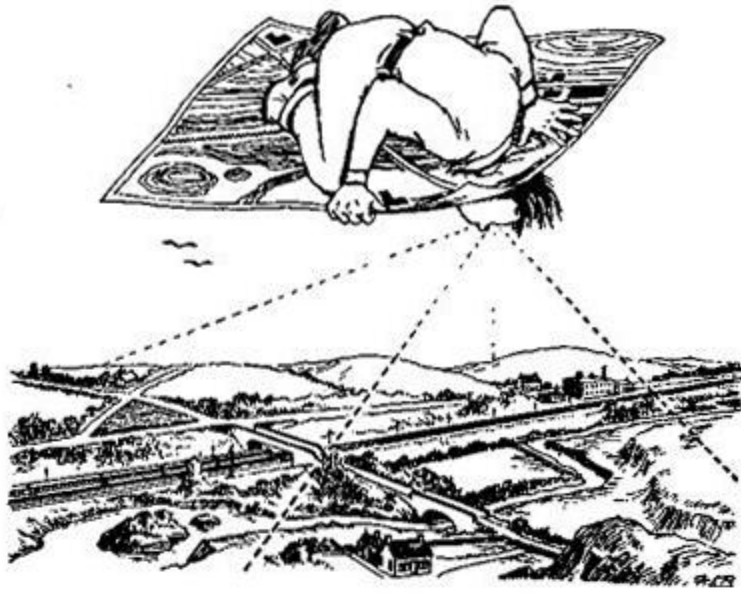

# Scale

In order to draw a map of manageable size we use a process called scaling to insure the correct miniturisation of the landscape on the map. Typical scales used are half inch to the mile, one inch to the mile. In such a scaling system one inch on the map represents one mile on the ground. Therefore the bigger the scale the more information it is possible to draw onto the map. For walking purposes you will be using the Discovery Series of maps which have a scale of 1 : 50,000 or 2 centimetres to a Kilometre or special trail maps 1: 25,000 ( 4 centimetres to 1 kilometers)



# Grid lines

Overlaying all maps you will see a grid of light lines running from top to bottom and side to side on the map. The purpose of this grid is to allow us to identify every part of the map with a unique number system ( grid reference). These grid lines, which correspond with the lines of longitude and latitude, also enable us to identify the north of the map, and aid us with compass alignment. You will notice that each line is given a number, this will help us to create the grid reference number.

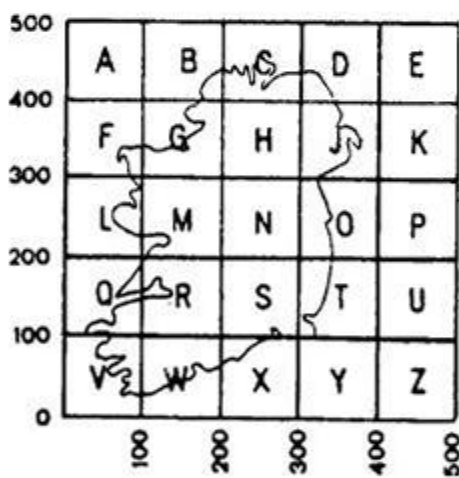

# Grid Reference

A grid reference is a series of numbers (co-ordinates) which give us the exact location on a map. It is created by using the grid lines which appear on all ordnance survey maps using the following steps.

1. Find your location on the map. If possible choose a recognisable feature rather than a point in the middle of nowhere.
2. Find the grid letter on the national grid by looking at your map. These are printed in blue and are large in size. Quote the letter of the sector, your position is in!!.
3. Start at the bottom left hand side of the map, and move across the grid lines until you arrive at the grid line nearest your location. The number of this line is the first two numbers of your reference.

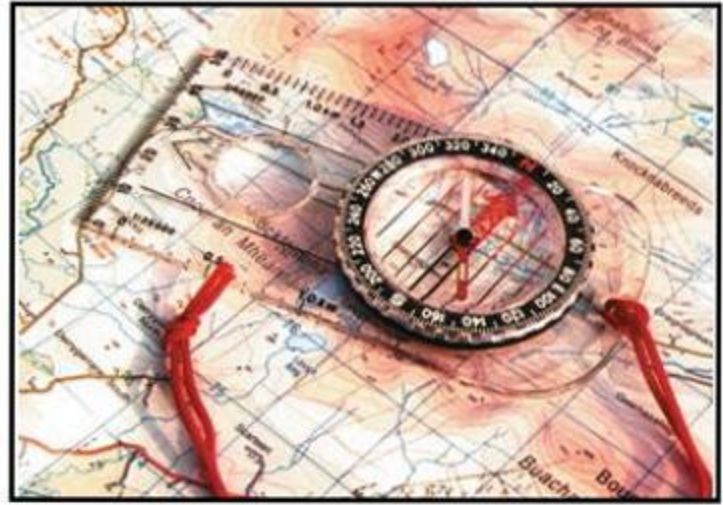

4. You should then divide up the grid square into tenths. Half way is 0.5, three quarter the way is 0.8 etc. State the location of your position as a decimal. This number is the third number of the grid reference.
5. Repeat the same steps for the grid lines that cross the map and this will give you the 3 figure reference for your location.
6. You now have your six figure reference for your position.

A simple rule of thumb is the phrase - 'go in the door and up the stairs', which means that if you visualise a door at the left hand side of the map - then you go in the door (give the bottom line first) then go up the stairs (give the side numbers next)

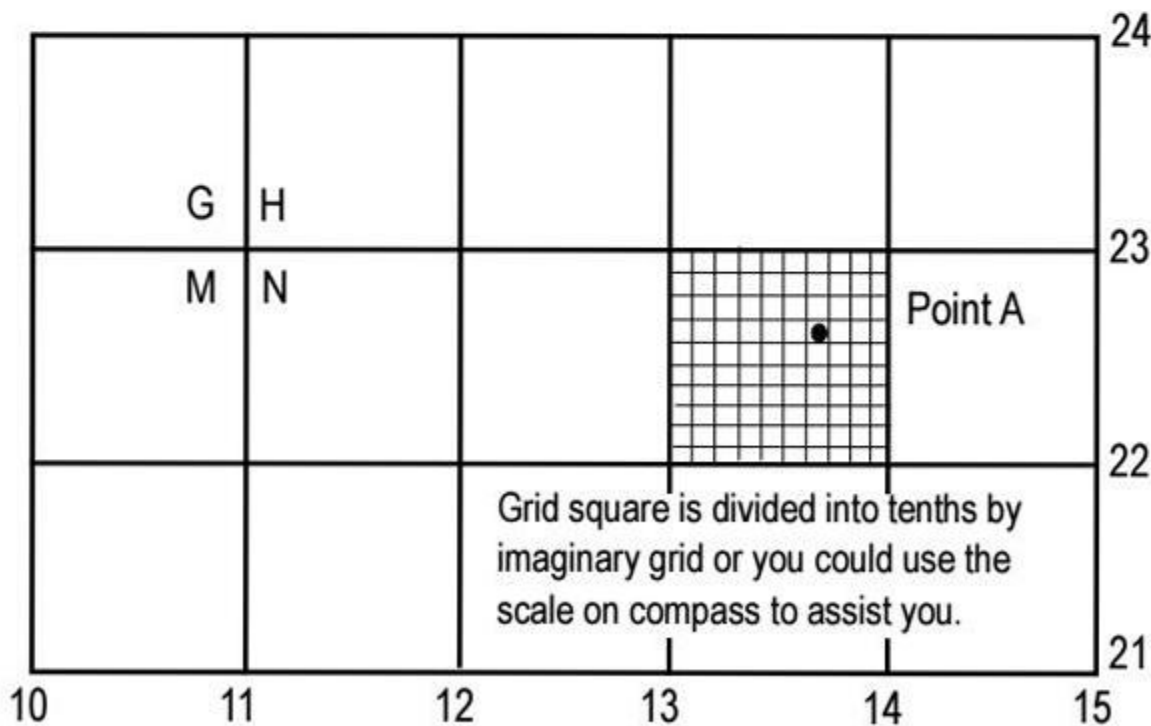

Grid reference for point A is N 137 227

# Aligning a map

In order to read a map correctly, you must first align the map. This is done by moving the map around until the map and the landscape correspond. This is usually done by selecting a landmark or

feature, finding that landmark or feature on the map, then align the map so that when you look at the map and then at the landmark, an imaginary line is drawn between the two points. When your map is correctly aligned you will be able to identify other features from map to ground, the mountain peak on your left or the stream junction on your right. If



this exercise is done correctly ( by aligning your map with two or three features rather than just one) you can now travel by using the map alone, provided you established correctly where you are standing in relation to these features. As each feature or new feature appears on the trail identify it on the map and re-establish your position.

# Contours

Contours are used to convey the shape of the terrain you are crossing. They are created by an imaginary line along which joins every point that is the same distance above sea level. These lines are drawn at 10 metre intervals, and allow us to see a representation of the shape of a hill or mountain. By looking at your map, you can determine whether the mountain has a steep slope (contour lines close together) or a gentle slope ( contour lines spread apart). Contour lines are rarely circular in shape. Because they are plotting ground level at set points, they allow us to see the gentle curves of a mountain as well as deep gullies. Practice on the ground with your map will provide you with hands on experience. Over a period of time you will get to know what variations of contour lines mean and how they translate to reality on the ground.

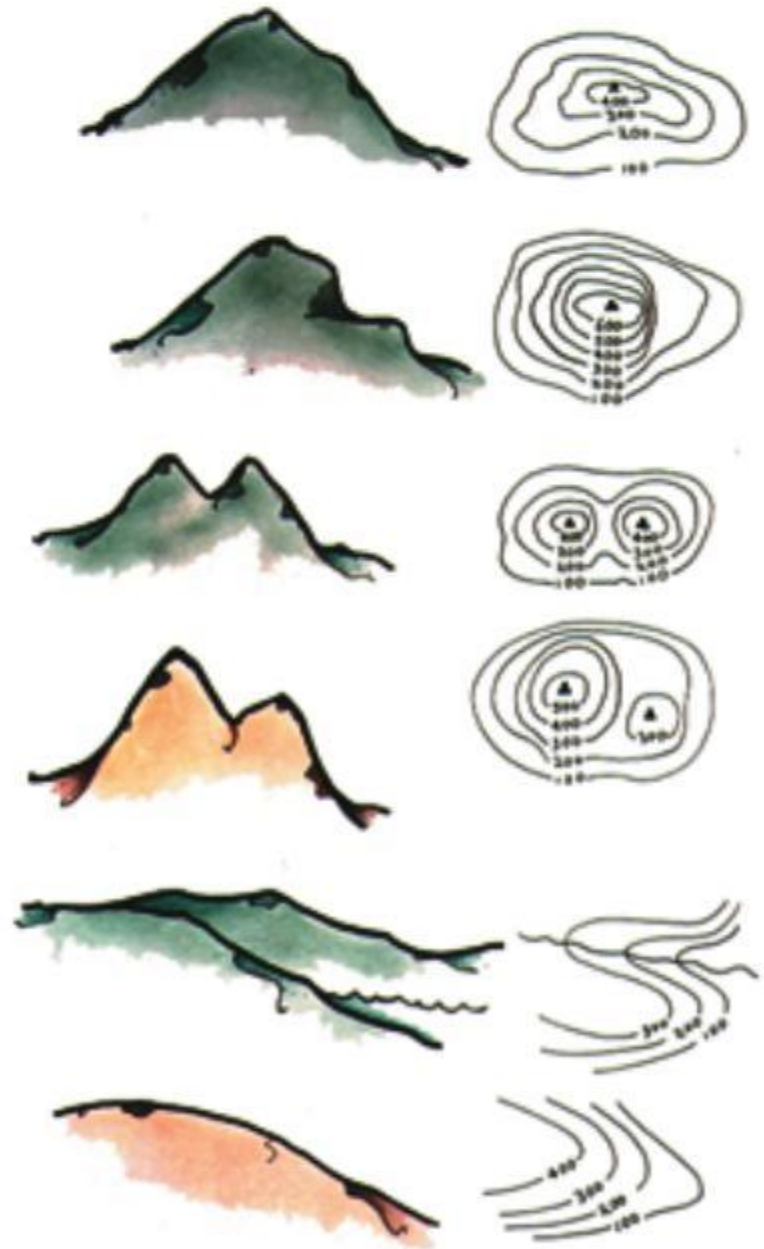

# The Norths

A compass points to one north(magnetic), your map is drawn with grid north, and the stars point to true north. What is the difference and how can you come to grips with them.

## True North & Grid North

True North can be determined by sun readings and from the stars and is the point we would the north pole the very top of the earth where all the lines of longitude converge. There is only a few degrees between grid and true north that we can take them to be the same direction.

## Magnetic North

This is the north that is indicated on our compass. Magnetic north is the location of a part of the earth which is magnetic and attracts the needle of the compass. This north is located above Hudson Bay in Canada. (8 degrees west of grid north)

## How is each used

If you get lost or do not have a compass then you will rely on the sun, stars and nature signs to show you the direction to follow. The direction you will seek is true or celestial north. It is only a general indicator and no fine navigation will be done by this method. e.g. If you are lost and you know that from the last time you looked at a map that a road was to the east of you.

What you would do is determine where north was by using the stars or sun and create a compass in effect. If you are facing north then east is to your right, west is your left and south is to your back.

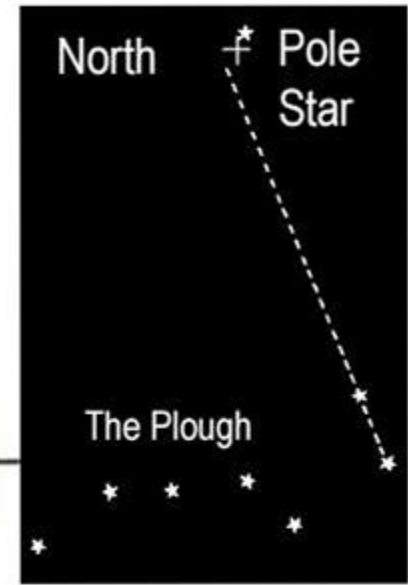
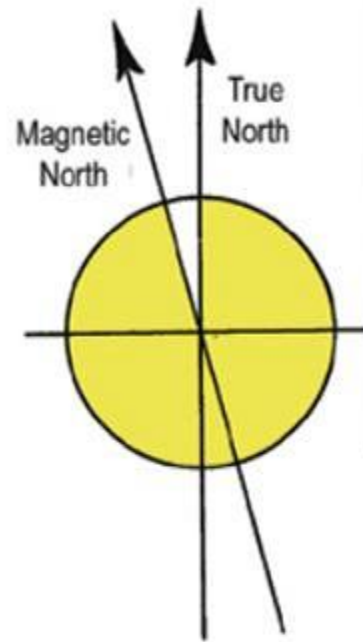

Every map is created with the top of the map being north and the bottom south. If you have your map folded up and you can read the writing on the map ( it is not upside down) it is turned in the right direction. This is an important point to remember when it comes to taking a compass bearing from your map.

## Magnetic bearing

The magnetic north is the north that your compass needle will always point to. This magnetic field is constantly moving. In Ireland the current variation (2012) is 4 degrees west on the east coast and 5.5 degrees on the west coast. Check the side panel of your map to see what the current variation is. This means that your map and your compass or out of line with each other. So in order to take a directional bearing from the map and translate that to the compass for you to follow you will have to add on the variation of 6 degrees ( for convenience we use 6 or 4 degrees - 3 or 2 marks on the compass depending on location). This variation is different in every country so always check the side panel of your map for the correct variation.

# The Compass

The compass is an instrument that tells us where magnetic north is. A magnetised needle is allowed to float freely within the instrument housing. Around the edge of the compass is plotted a circle on which markings similar to that on a ruler are inscribed. Each marking determines the number of degrees it is from north to this point.

There are many compasses on sale from the simple floating needle type to the more expensive plotting compasses. We will only be concerning ourselves with one compass and that is the Silva Compass. This is the best compass and only compass you should use for navigational purposes on land.

The Silva Compass is made up of three parts - the needle, the compass housing and the base plate. The needle is coloured red and white, and the red end points to North the white to the South. The compass housing revolves and determines the desired bearing or direction of travel. The base plate is used to indicate line of travel.

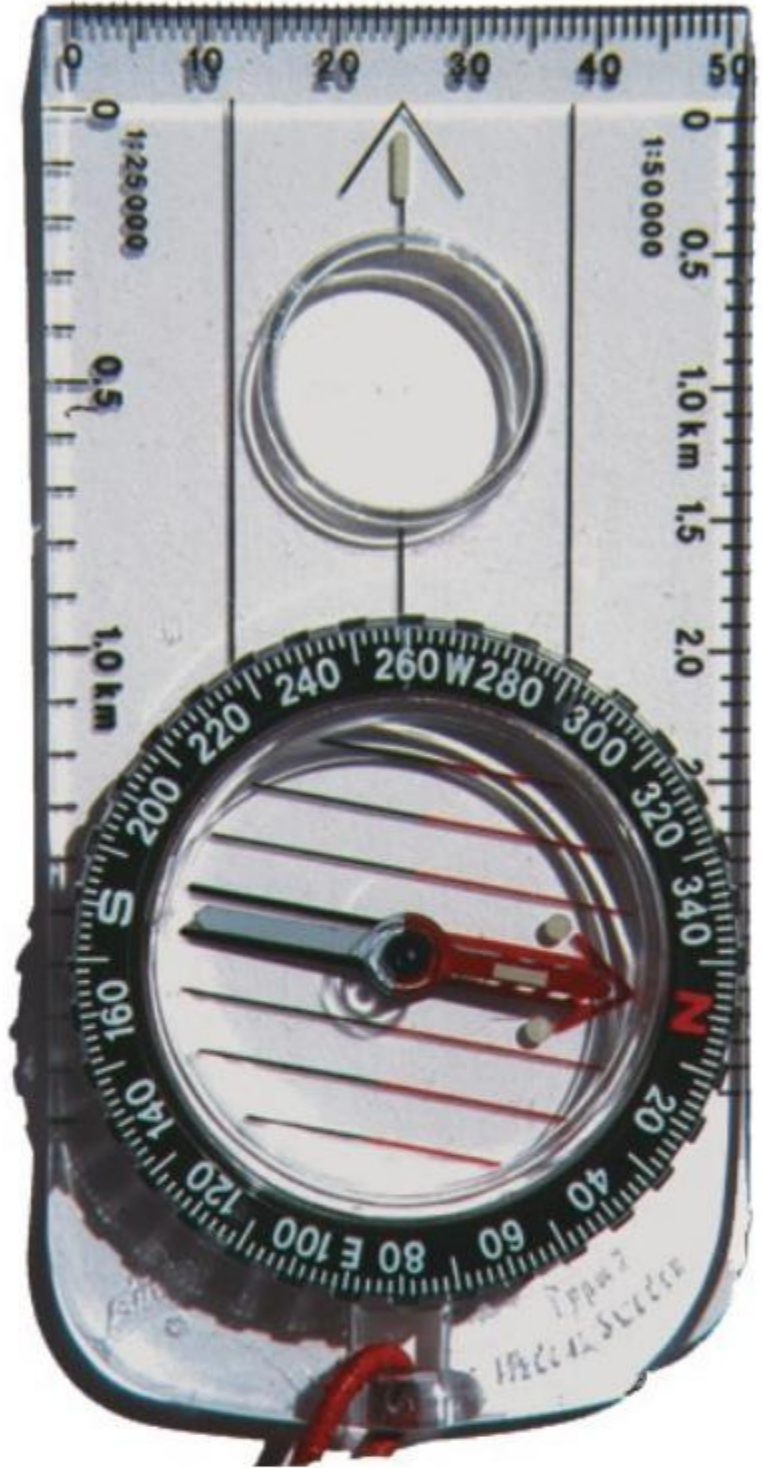

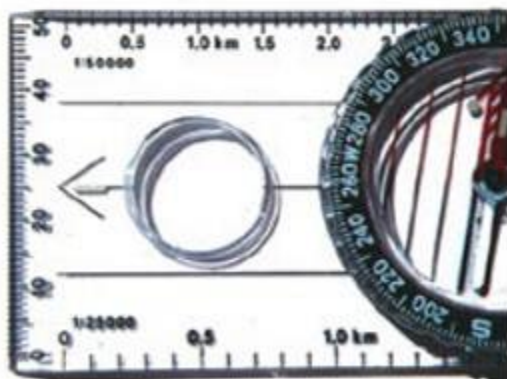
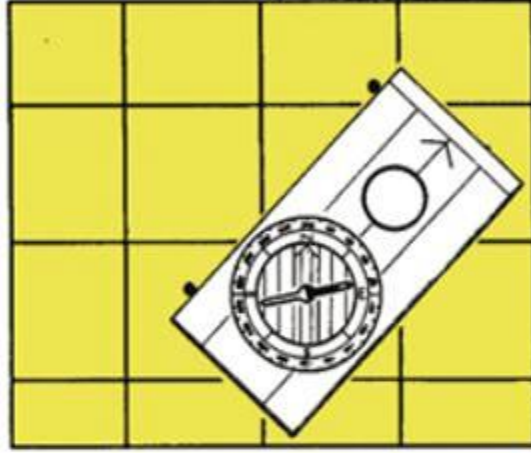
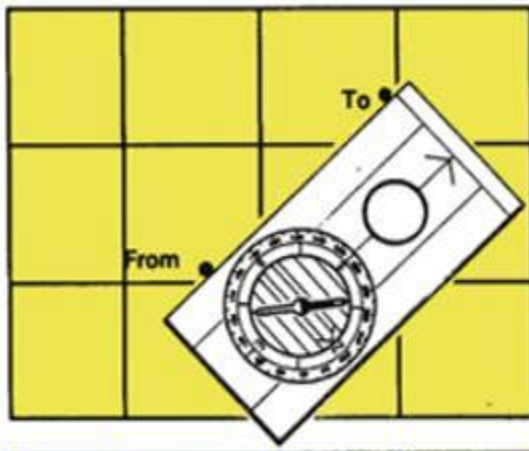

# How to use your compass

Your compass is a tool that is used in conjunction with your map. By using the compass, it is possible to navigate very precisely between points on a map. Your compass can also be used to check your position on the map, and to check the correctness of your line of travel.

## Taking a bearing

Place the compass on the map with the edge of the base plate along the desired line of travel. The direction arrow on the compass should point to the place you wish to go.

Move the compass housing until the north-south lines on the transparent base of the compass housing are parallel with the grid lines on the map. The north arrow on the compass housing should be pointing to north on the map. You should be as accurate as possible when lining up these lines as a movement each way will add or subtract degrees from your final bearing and result in bad navigation and missing your destination by hundreds of metres.

Lift up the compass and read the bearing indicated on the compass dial. Say this number to yourself then add on the magnetic variation (e.g. the bearing is 92 degrees, add on the variation 4 degrees, the result is 96 degrees) now move the compass housing to this setting. It is a good practice to do bearings this way rather than adding on by moving the compass housing immediately so that you do not make a mistake. It is better to confirm the bearing in your mind first before you move the compass.

Your compass is now set. Hold the compass in your hand and move your body around until the red part of the needle of the compass is correctly aligned with the north - south markings on the housing. The direction of travel arrow on the compass now points in the direction you need to travel to your next destination. Keep your compass level at all times so the needle can move freely within the housing when finding your direction.



This exercise is repeated from point to point as you travel on your journey.

## Following a bearing

You travel on a bearing by sighting a recognisable landmark along its path and then travelling to that point and repeat until you reach your destination. It is not advisable to follow your bearing by looking at the compass and watching the movement of the needle. As you walk you will have to move from side to side to avoid obstacles so this method of following the bearing is discouraged in favour of line of sight identification method. However, if you find yourself in heavy fog or out at night you will use the method of looking at the compass to find your way. In fog or at night you could use members of your party to line up on the bearing under your direction and you then travel to these members. This is a more accurate method than simply looking at the compass.



## Back bearing

If you think you have erred from your line of travel you can check your bearing by using a back bearing. To do this you turn yourself around and point the compass back to your last location. The white part of the needle rather than the red, should now point to the 'N' mark on the compass dial. If it is slightly out, then it is possible,

by walking left or right until the needle lines up, to correct your line of travel.

# Finding your position on a map

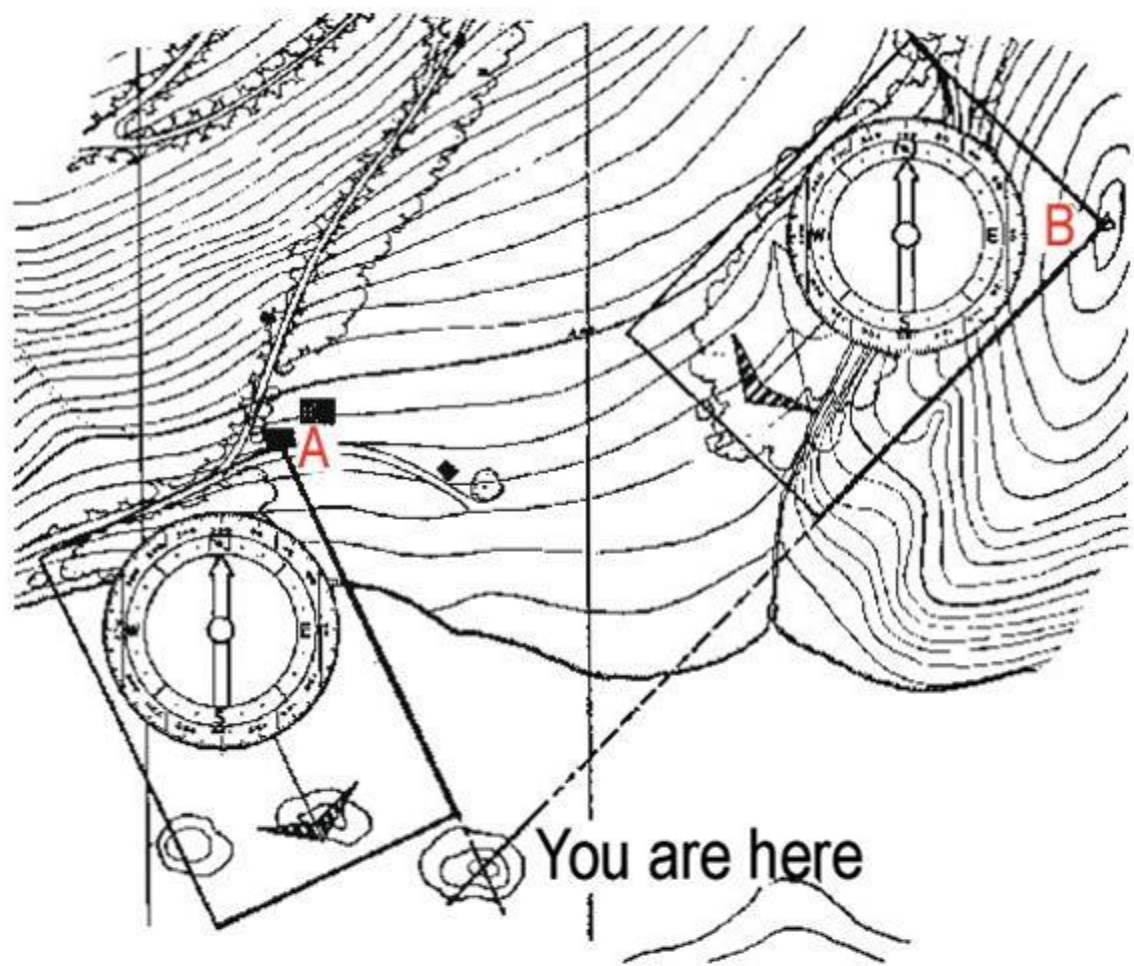

To find our position on a map, we use a process called resection. This is performed by plotting at least two points on the map to determine your position.

First, select a landmark that you can identify on the map and from the position you are standing.

Point the compass at the landmark and move the housing until the needle and north - south marking align. Read off the bearing on the dial. Now subtract 8 degrees (magnetic variation) from that bearing. (e.g. bearing of 88 degrees less 8 degrees total 80 degrees). You then place the compass on the map with the edge of the base plate on the symbol for identifiable feature. Without

adjusting the compass move the whole compass round this point until the north - south lines are parallel with the grid lines. If you have a pencil, draw a light line along the side of the base plate. Your position is somewhere along this line.

Now select another feature which can be seen and identified from your position and repeat the process. If possible, choose a feature which is nearly 90 degrees from your position. By doing this your new line will cross the line drawn from the other feature at your precise location. If the two points selected are too close to each other then the lines will tend to merge and may result in a less accurate

determination of your position.

Normally, two bearings are ample, however, if you wish you can use three to confirm exactly where you stand.

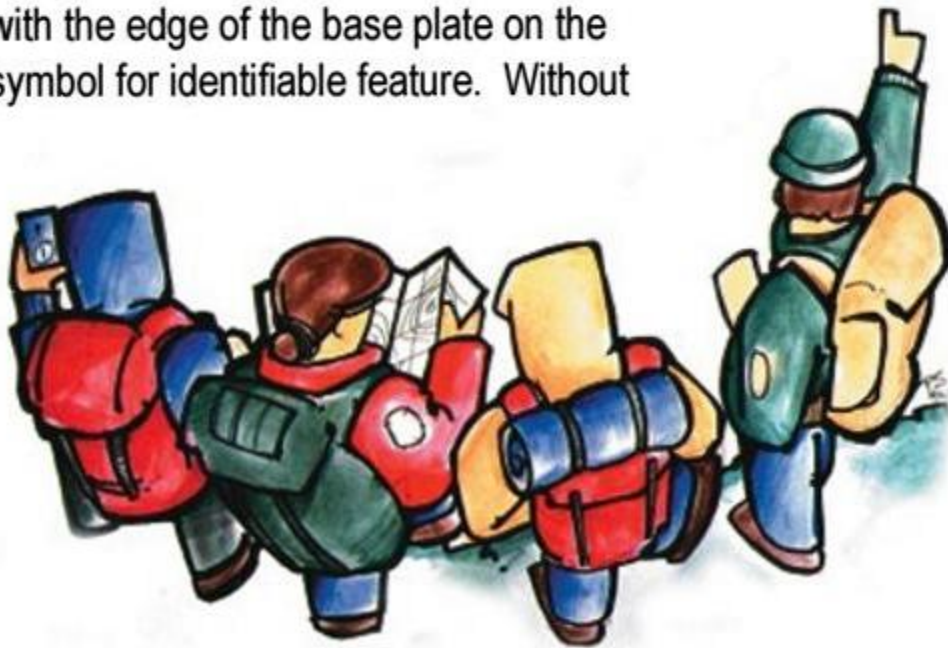

# Nasmiths Rule

Nasmith's rule is a method of determining our speed of travel over the countryside. It states that we walk at 3 miles per hour and that we must add on to this calculation half an hour for every 1000 ft climbed. This calculation can be converted into a metric measurement thus - we walk at 5 kilometres per hour and allow 30 minutes for every 300 meters climbed. For the purposes of calculating time travelled it is better to use a figure of 4 kms per hour.

These calculations can be simplified

## Walking

15 mins per 1 kilometre  
7.5 mins per half kilometre

Plus height climbed  
1 minute for every 10 metres  
climbed

These simplifications allow us to calculate with ease. Measure the distance with the rule on your compass, 2 centimetres = 1



kilometer = 15 mins travel time. Count the number of contour lines you pass on your way up, each contour line = 10 metres = 1 minute extra to your travel time. You do not add on time if you are descending a mountain or high ground. Be careful reading contour lines on the map. You may have to calculate the height gained in metres or feet depending on the map used. ( If you are using the discovery series of maps it will be meters) Your start off position may be at the 150 metres line and you may travel through to the 250 metres line you have therefore climbed 100 metres, meaning you have to add on 10 minutes to your distance travelled time to give you your correct arrival time.

4 kilometres per hour is a suggested average for hiking across easy ground with a light pack. If you intend to carry heavy packs or if you are travelling through rough countryside then you will have to adjust this figure. The chart opposite will give you some guide, 2.5 kms per hour is the suggested figure for planning your route if you are participating in a Mountain Pursuit Challenge. In determining the correct speed of your Patrol it is a good exercise to measure out a set distance, and time your Troop over this distance, walking at an average pace, with packs, etc.

This simple rule enables us to navigate across rough ground with precision. We can also use this calculation to plan hikes and adventures into wild country without leaving our sitting rooms.

# Route cards/ planners

Route cards are a device we use to plan our adventures across rough countryside. The route card/planner tells us essential information about our proposed route, number in the party, etc. The card also serves as a safety device as we should leave a copy of the route card with a responsible person who is not taking part in the hike or trip. If an emergency arises then this person can advise the rescue services of your route and aid your rescue.



## Filling out a route card

In preparing a route card we break up our journey into convenient sections or 'legs'. Each leg is then treated separately to calculate distances, bearings etc. Each point of reference on the route card is identified with a grid reference. So, you will be travelling from grid reference to grid reference rather than from the 'edge of the forest' to 'the river'. Grid references give us a precise position on the map whereas the edge of the forest is open to different interpretations. The direction of travel between two points is determined by a compass bearing. These bearings are obtained from your map ( don't forget to add magnetic variation) The next steps are to determine the distances you will travel between points and the height gained and calculate the total time for each leg of your journey. You will also need to add in such things as -

stopping to admire the scenery, and rest time. A general rule is to allow 15 minutes per hour. This 15 minutes may be spread over a number of legs. In arriving at your total time, you should also add in time for lunch or meals as required. You should take note of the actual time that it takes to complete each section, and put this figure down on your card. This information will be useful if you decide to do the route again at a later stage. It is also useful in determining your accuracy, which will improve with practice.

$$\begin{array}{l} \text{LEG 1} \\ 1 \text{ km @ } 4 \text{ km/H} = 15 \text{ mins} \\ 300 \text{ mts @ } 10 \text{ mts/100} = 30 \text{ mins} \\ \hline \text{TOTAL} \quad 45 \text{ mins} \end{array}$$

$$\begin{array}{l} \text{LEG 2} \\ 5 \text{ km @ } 4 \text{ km/H} = 7 \text{ mins} \\ 50 \text{ mts @ } 10 \text{ mts/100} = 5 \text{ mins} \\ \hline 12 \text{ mins} \end{array}$$

# Walking Speed

The speed that you can travel across open countryside is determined by the type of terrain you are crossing on a given leg of your journey. See chart for guidance, however a good estimate can only be determined by calculating your pace over a 100 meter distance. This is particularly necessary if you will be crossing boggy ground or difficult terrain such as high heather or ferns. Weather can also be a factor in your calculations, especially in driving rain, wind or snow conditions. Take these items into account as you proceed on your journey and recalculations may need to be made as you complete each leg. Always have alternative routes or escape routes planned into your journey in case weather conditions change or there is a need to get to safety quickly.

Height Climbed
10 minutes for every 100 metres climbed
1 minute for every 10 metres climbed
30 minutes for every 300 metres climbed
3 minutes for every 30 metres climbed

Rest Time
Allow 15 minutes per hour rest time over the period of your journey.
Allow time for lunch usually 30 minutes

Rough estimate of walking speeds				
6km/h	5km/h	4km/h	3km/h	2km/h
Fast road walking	Good pace no pack	Good ground with pack	Rough ground heavy pack	Very Rough Ground Pack

Step 1. Measure the distance from the map along the length of the chosen leg as accurately as possible.

Step 2. Estimate the time necessary to travel this distance, from chart and from your own experience.

Step 3. Calculate the height gained over a given leg. (Do not add in time for descending unless the terrain is very steep or difficult).

Step 4. Add the two times together to give overall estimated time for completing the leg and enter this time on your route card

Route Card							
Date of Activity		8 Jan 2001		No. in party		8	
Mobile Ph.							
Location	Grid Reference	→ Grid Reference	Action	Distance	Height	Time	Bearing
RIVER BRIDGE	N734 756	N736 763	FOLLOW FOREST TRACK	1 Km	100 mts	25 mins	243
GATE	N736 763	N736 772	FOLLOW BEARING	.5 Km	30 mts	10 mins	220

General description of activity		Totals		8 Km	1000 mts	5 Hours
CIRCULAR ROUTE FROM BIG HILL CARPARK OVER ROUND HILL AND PEAK MOUNTAIN AND RETURN TO CARPARK VIA HEARY WAY TRAIL		Departure time		10.00 AM		
		Expected return		5.00 PM		
		Rest time		2 Hours		
		Overall time		7 Hours		

# Walking the trail

Walking is a natural skill and anyone who can walk can hike. But hiking often involves long distances and rough terrain, and therefore added stress. Here are a few suggestions on how to make your walk more enjoyable.

You should walk with your toes pointing forward, not to the sides. An inward or outward orientation of the foot causes an unnatural torque, or twist, on your ankles.

On level terrain, try to hold your torso (upper body) as vertical as possible. A fully erect posture distributes body weight efficiently and is especially important when carrying a pack.

When going uphill, your initial tendency is to lean too far forward. This causes strain, and you will tire more quickly. So lean forward only slightly. Don't over compensate for the uphill slope.

Going downhill is even more tricky. As you travel downhill, your knees act as brakes, absorbing the forces of gravity and momentum.



Steep downhill grades are hard on the knees and leaning backwards only makes things worse. It can also cause your feet to lurch right out from under you. If your knees begin to ache, bend slightly forward. This seems awkward, but with practice you will get the hang of it.

Another thing about coming downhill; If your boots are too small, or laced tightly, your toes will ram into the front of the boot. This is painful and can even cause the loss of a toenail if unchecked. So, when choosing new boots, stand on your toes. If the boots hurt then, they'll hurt going downhill too.



# Route Card

Date of Activity

No. in party

Mobile Ph.

Location	Grid Reference →	Grid Reference	Action	Distance	Height	Time + Rest	Bearing
Totals							

General description of activity

Departure time

Expected return

Overall time



Never jump or leap while carrying your rucksack. With the extra weight on your legs as you land it can result in injury, as well as the hazards of falling off balance.

For steep uphill travel, take your time and travel at a steady pace. You should travel up the hill by a method of traversing from side to side in a zig zag fashion rather than a direct assault.

Care should be taken when hiking over rocky or uneven ground. Place your feet deliberately from step to step, as this will prevent stumbling.

Some hikers find a walking stick or stave is useful. When crossing rivers the stick can act as a third leg that helps you keep your balance. It can also assist you in descending steep slopes.

ON THE MOVE

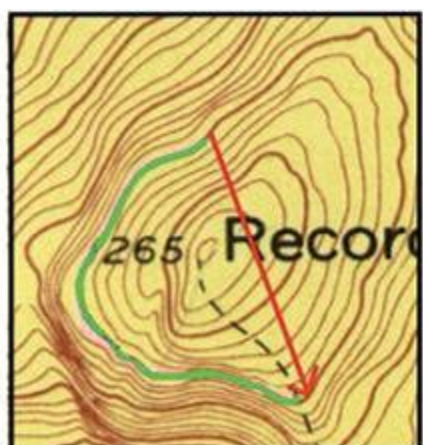
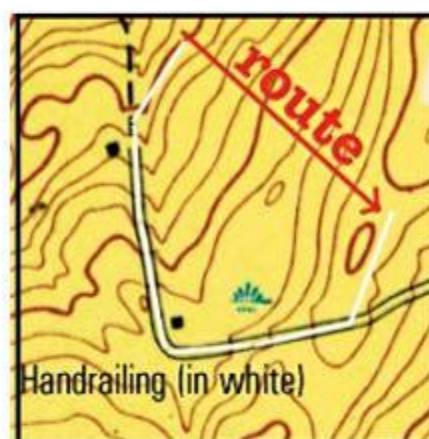
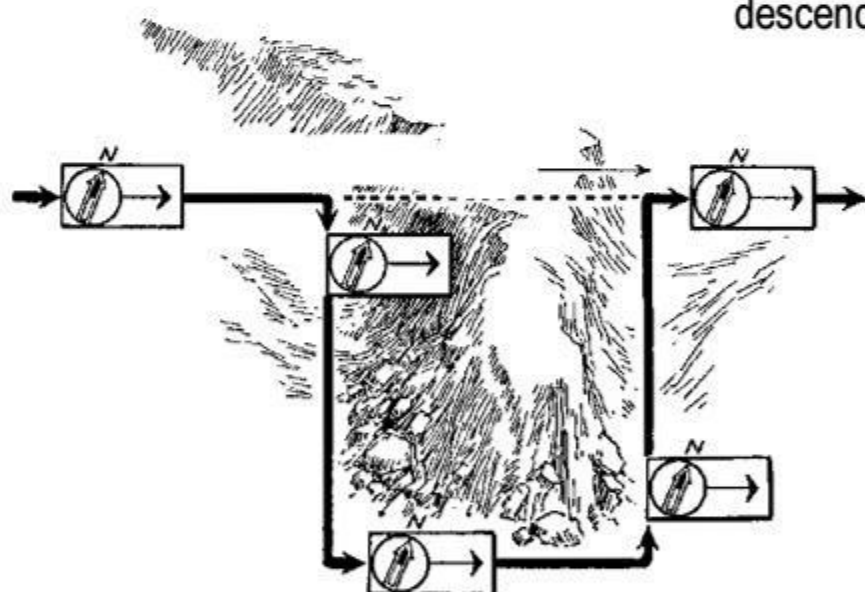

When travelling over rough terrain navigation can be difficult. Using natural 'handrails' such as tracks or rivers will make travel easier. Likewise you can also travel along a contour line rather than take the more direct 'over the top of the hill' method. You can also bypass an obstacle by detouring. Do not reset your compass. Travel around obstacle to selected point on other side and continue on route. If conditions are bad then travel around obstacle by adding and subtracting 90 degrees from your compass bearing

# Leading a Patrol



## Setting the pace

The pace of the Patrol should be that of the slowest member. A comfortable pace will allow everyone to talk freely. If there is a lot of huffing and puffing then the pace is too fast. On uphill sections your pace should be slow and calculated, bringing the whole group up the hill together. It should not be necessary for the leader to be out front setting the pace, although this may be necessary if the group are walking too fast.

## Keeping the Patrol together

In traversing the countryside, the leader needs to be able to keep the group together. This can be done in a number of ways.

Set a manageable pace ( see above) and avoid crowding or stringing out the group.

Every group should have a person who acts as the 'rear man'. His/her job is to 'bring up the rear' and advise the leader if the Patrol is becoming strung out. The 'rear man' should be a senior and more

experienced member of the Patrol. The 'rear man' is literally that, he/she should be the last person in the Patrol, never allowing anyone to fall behind them.

The Patrol should wait after obstacles, to re - form the Patrol before setting off again.

The leader of the hike should take an active interest in their surroundings, and should be able to point out interesting features and points of interest. You may also want to check your map reading skills or show new members of the Patrol how to read a map. These are methods which can be used to bring the Patrol together, rest the Patrol, and add more interest into the hike.

Encourage members of your Patrol to lead different legs of the hike so that they can develop their skills.

If you have a problem with members pushing ahead too quickly, it is a good idea to put them to the back of the Patrol to assist with the stragglers.

The leader of the hike should find a central position in the group so that it is possible to control and monitor the Patrol from the front and rear.

## Crossing rivers, bogs and marshes

While on the trail you will cross many types of terrain. Rivers, bogs, and marshes have their own particular hazards. Care should be taken while crossing them. Avoid jumping from boulder to boulder while crossing rivers. Jump from tuft to tuft while crossing bogs. Stay clear of wet, boggy, peaty ground in the troughs of bogs. Detour around this type of ground rather than following your bearing to the letter. Avoid crossing stretches of bright



green moss on marshes. As you cross you will notice that it moves; it is floating on water. If you are unfortunate enough to find yourself sinking into a bog, 'swim' with a breast stroke to firm ground - don't try to jump. Spreading your body over the surface distributes your weight. It is a good idea to cross these obstacles in single file; the person in front finding the safest route across.

ON THE MOVE

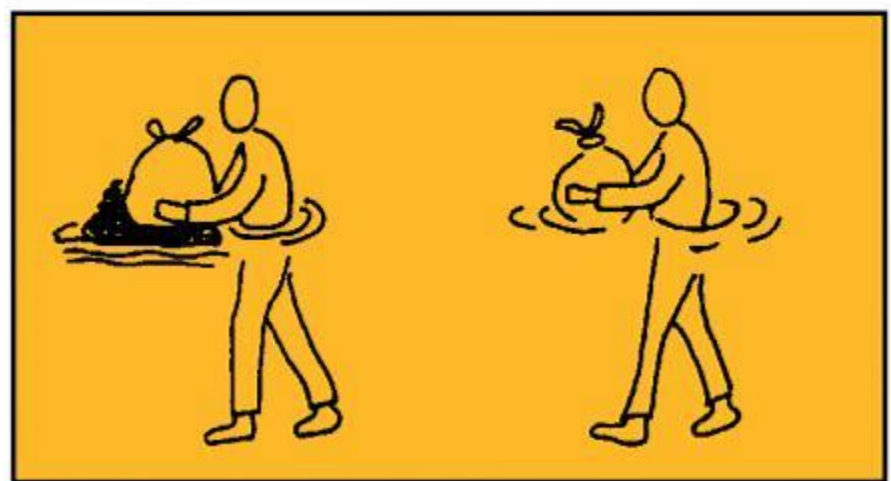
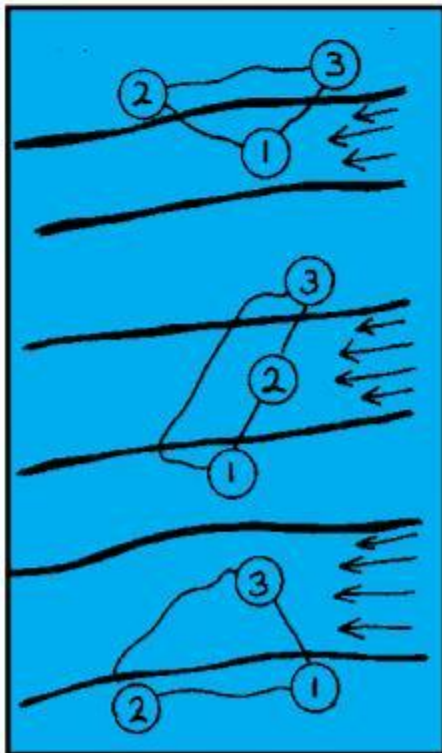

# River Crossing

River crossings at the best of times are hazardous, but in heavy rain, mountain streams can turn into massive rivers, sometimes covering stepping stones and low bridges or fording places. River crossing in such conditions should be approached with caution - if in doubt, turn back, or seek a safer crossing point. If there is no other option but to cross the river, then take note of the following points.

The river should be crossed at a point where it is flowing slowly rather than at rapids, just because it appears to have a number of stepping points available. It is often safest between bends. The bottom is often good and the water shallower. The water is also slower when the river widens and the safest place to cross can be a point on the river where a number of islands have been created as the river swells in size. Before attempting any crossing try to survey the river from a high point, which will enable you to view other hazards which might not be visible from the river bank.

Prepare your group before you attempt to cross. Remove heavy clothing to reduce drag and friction and keep them dry. Remove your socks also but wear your boots as you cross.

Rucksack belts and straps should be left open or loosened so that the pack can be jettisoned if you fall while crossing. If your pack has to be jettisoned, hold on to it. It will probably float so you can use it to right yourself.

A pole or stave should be used to provide a 'third leg'. It should be used in a pyramid fashion, using it in front of your body to probe the bottom of the river. Put your

weight on it only when you know it is secure. Cross the river facing the oncoming current as this will prevent you from falling over.

Buoyancy aids can be created by using survival bags, billies, and bottles. You may want to place all your dry clothing and rucksacks in a survival bag and transport it separately.

The crossing of all rivers in flood should be done with the aid of a rope. If a rope is unavailable then reconsider your situation.

Secure a rope on each side of the bank. Each member of the group should be secured to the rope, so that a link is formed with those on each bank of the river.

A leader should be the first to cross the river. Apart from the difficulties of fording the river the leader should also try and determine any underwater obstacles as he/she crosses so as to plot a safe route across for the Patrol

A diagonal crossing method is recommended. You should travel upstream and across if possible.

The leader should check every member of the group before they cross, making sure that every member is secured at all times as they cross. Once on the other side they should dry off and get into dry clothing.

# GPS Compasses

GPS compasses work by giving you your location with reference to satellites. The number of satellites used will determine the accuracy of the information on the screen. You should be careful as handheld GPS compasses are only accurate to within 10 metres square of your location.



Some tips for using a GPS Compass:-

- Always hold the GPS level if you are using the electronic compass and taking a bearing.
- Always point the GPS forwards in the direction of travel
- Try walking a few steps to confirm reading
- Switch GPS off when not in use to save batteries
- Don't forget to calibrate your compass when you switch it on.
- Read the manual about your GPS compass and be familiar with its workings before you venture out.



ON THE MOVE

## Geocaching

Geocaching is a real - world outdoor treasure hunting game using GPS compasses to location a geocache (container) hidden at a location. You can participate in closed games or open games available to everyone who wants to take part. The idea is to locate a geocache - you can take something from the geocache but you must leave something of equal or greater value.

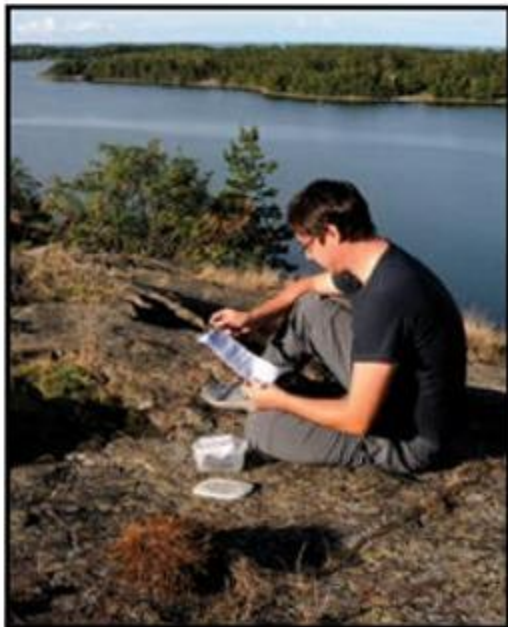

## Geocaches

Geocaches are located all over the world and are placed in the locations by fellow geocashers. Their location is then posted on a website where you can get information and co-ordinates. Similarly, you can log information of the geocaches you have visited and collect points on a score board. Search the internet - geocaching - for further information.

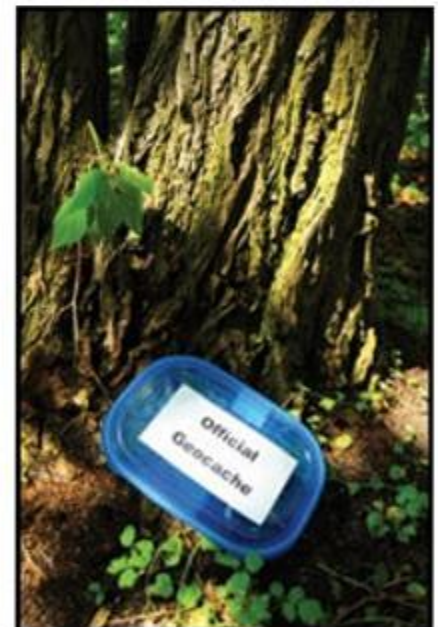

# Safety notes -

Particularly for those leading a hike or adventure in wild countryside

Before you set out on a trip obtain as much information as you can about the area.

Check all equipment before you start. This should include the checking of the contents of individual rucksacks by the Patrol Leader. You should be wearing boots and have proper raingear. Improper or inappropriate gear will lead to problems, problems you can do without in open countryside if things get difficult.

Make sure that a copy of your route card is left with a responsible person, who you can contact if there is an emergency or delay. Your parents should be made aware that delays can happen and if the

group is late returning it can be related to a lot of different factors such as difficult terrain, weather, missing the bus!! All delays are not due to an accident. However, this is not an excuse for bad planning.

Bring a first aid kit , adequate for the trip planned, and some emergency food and drink rations.

Check the weather and know its effect in your selected area ( micro climates - see later). Listen to the detailed weather forecast on the radio or dial the weather forecast service.

Check times of buses, trains etc.

Safety must be uppermost in your mind. Don't take unnecessary risks. If you think you will require extra equipment then ensure you have it with you. It is a good idea to have a walking rope with each Patrol Leader as well as a survival bag and a sleeping bag. Exposure is a very real emergency which you may have to deal with, and a survival bag and sleeping bag are invaluable in such situations. A walking rope is useful if you have to cross rivers or even as an aid in descending loose scree or slippery grass or rocks. This extra safety equipment can be shared among the Patrol. You should have your own survival bag, individual survival kits and your own personal first aid kit.



Plan for an emergency, identify escape routes from any part of your proposed route. These escape routes should be indicated on your route card so that the contact person is aware of your plans in case of difficulties.

Take note of the health of your Patrol. Is any one sick?. Has anybody got an injury, such as a blister on their foot, or a sports injury such as a bruised knee. Does any member of your Patrol need special medical attention? such as diabetics, or asthmatics etc. You should also be aware of the capabilities of your Patrol. There will be strong, medium and below average walkers and this

cannot be judged by assessing their build or apparent strength. Nobody likes to admit to being below average or unfit but they must be persuaded to be truthful. In a stress situation the below average person is more likely to be the first casualty. Take time in your training period to develop walking skills and to increase the fitness of your Patrol.

Finally, before you depart you should brief your Patrol and your Scout leader so that they know where you are going and what you intend to do during the activity.

