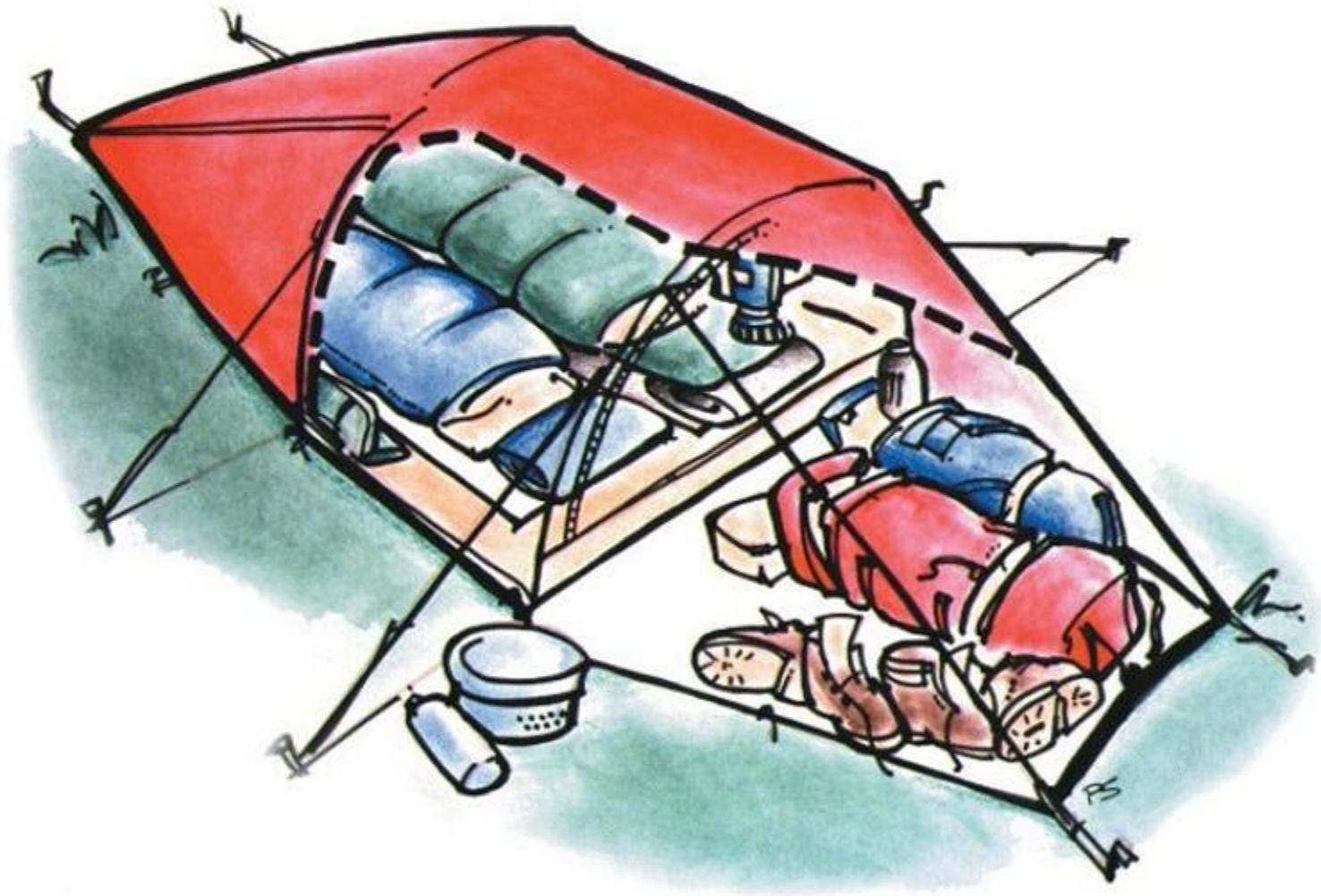
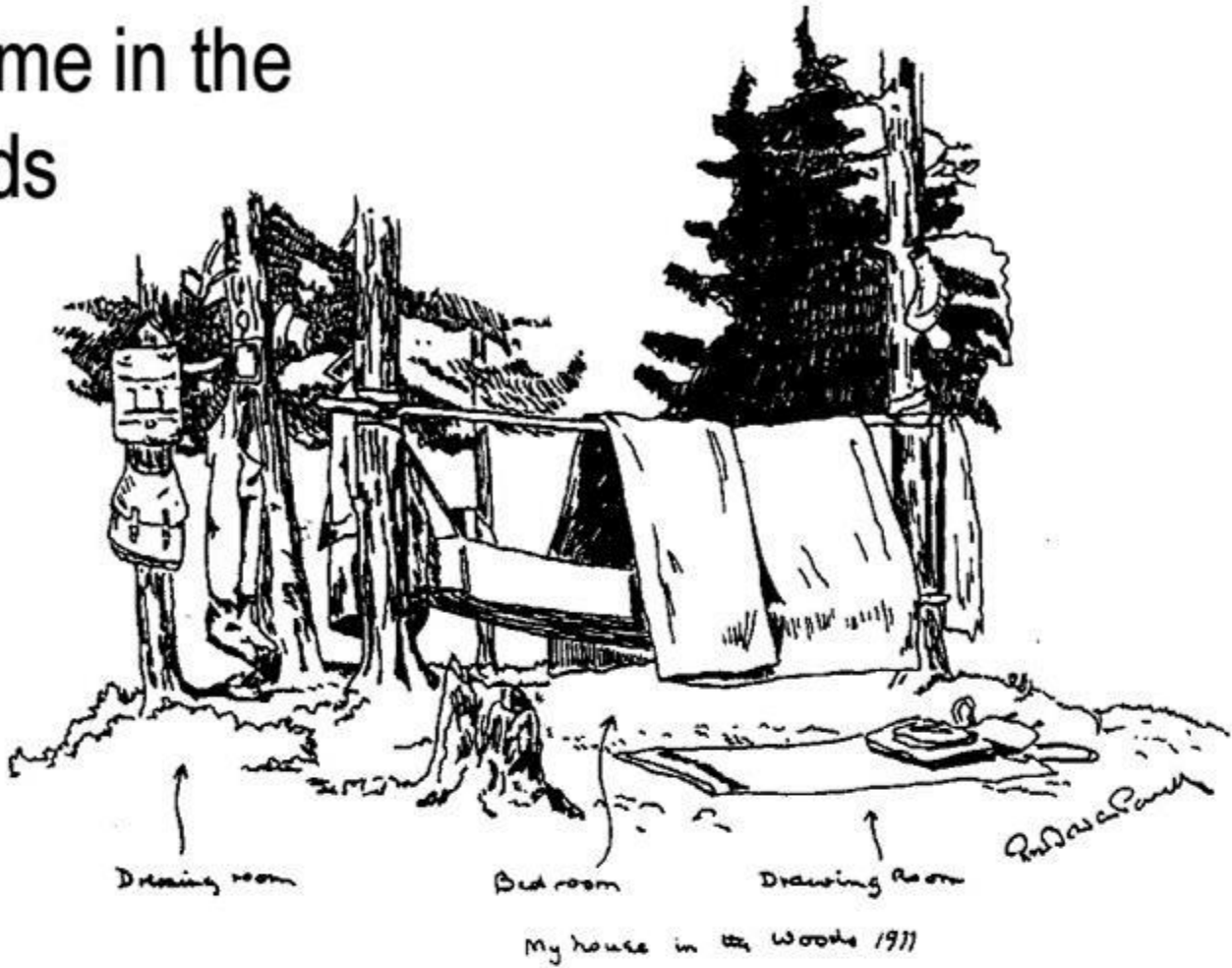


Room Outside



A Home in the Woods



Extract from an article for 'The Scout' Magazine written by Baden - Powell from his campsite in Canada in September 1911

ROOM OUTSIDE

"Here I am camped by a rushing river between forest-clad hills. It is close on ten in the morning. I turned out at five, and yet those five hours have been full of work for me, albeit it was no more than little camp jobs.

The fire had to be lit, coffee and scones to be made. Then followed boiling -and sand-scrubbing the cooking utensils; collecting of firewood for the day (both kindling and ember-forming wood) ; a new crossbar and pot-hooks had to be cut and trimmed ; a pair of tongs for the fire, and a besom for cleaning the camp ground had to be cut and made. Bedding had to be aired and stowed; moccasins to be greased; the camp ground swept up and rubbish burned; the trout had to be gutted and washed. Finally, I had a shave and a bathe; and here I am ready for the day's work whatever it may be. But this took five hours to do.

My comrade went in yesterday to the nearest hamlet, and will be back to-day with our letters and supplies. He will find me away fishing or sketching, and gathering berries for our "sweet" of stewed fruit at dinner; but he will find the camp swept and garnished, fire laid ready to be lit, cooking pots, cups, and plates all ready and clean for his use, and food handy.

We may probably "up-stick" and travel on later in the day, and see some more of the beauties of the land, as we "hump our packs" to the next nice-looking site for camp. Then comes all the business of pitching camp, getting water and firewood, cooking food, and making oneself comfortable. All a succession of very little jobs, but which in their sum are important. They all give enjoyment and satisfaction to the older man, while to the young person they bring delight, experience, resourcefulness, self-reliance, thought for others, and that excellent discipline of camp-tradition"

September, 1911

Choosing a campsite

The choice of a campsite is determined by a number of considerations:-

- A clean water supply
- Protection from the elements - wind / wind direction and rain
- Level ground for tent pitching
- Drainage of the site
- Availability of wood and food supplies

The site should, as far as possible, be an interesting and picturesque place to camp. The kind of place where you can forget about the city, town and civilisation and where you can feel like real pioneers and explorers of the frontier.



In general the site should be on high ground, rather than in a dip or lower ground that will collect water in wet conditions. The site should be sheltered, perhaps with a forest or wood to the back of it. Be careful to keep away from overhanging branches which can fall in stormy weather or more seriously will drip water long after the rain has stopped and leave sticky insect larvae on the tent. What is the nature of the ground you will be camping on? Is the grass very long, is it possible to hammer in tent pegs or is the soil sandy or very soft so that you will have difficulty getting pegs to hold - a serious consideration in bad weather conditions. Check also for insect life. Some campsites, particularly those near damp ground or

close to scrub or fern undergrowth can attract flies and midges which can be extremely annoying, especially in the evening.

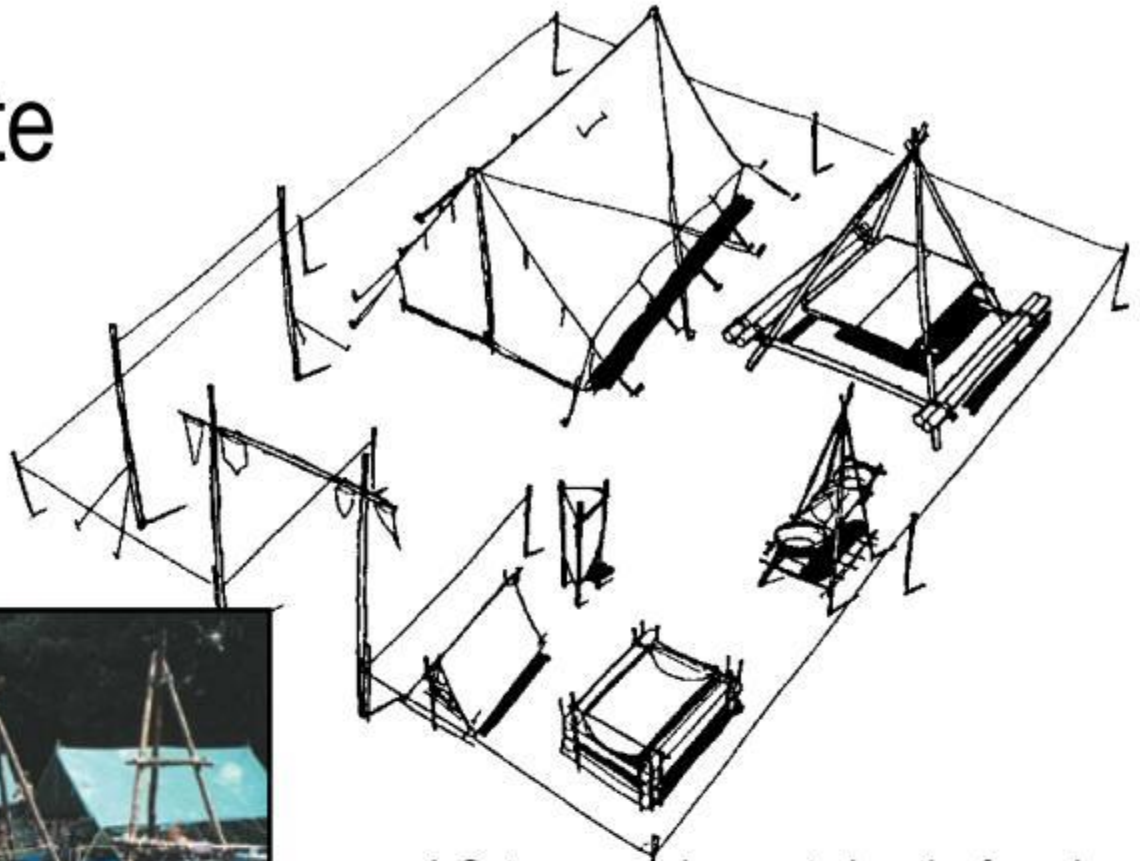
The business of Scouting is the programme of the camp. What do you plan to do on camp? The basic living on camp will require such items as food, water and wood for fires etc., whereas the programme will require forests, open ground for games, places to hike to and explore and a safe place to swim.



Don't forget to find out about camp fees and if the Patrol are required to undertake a service project during your stay.

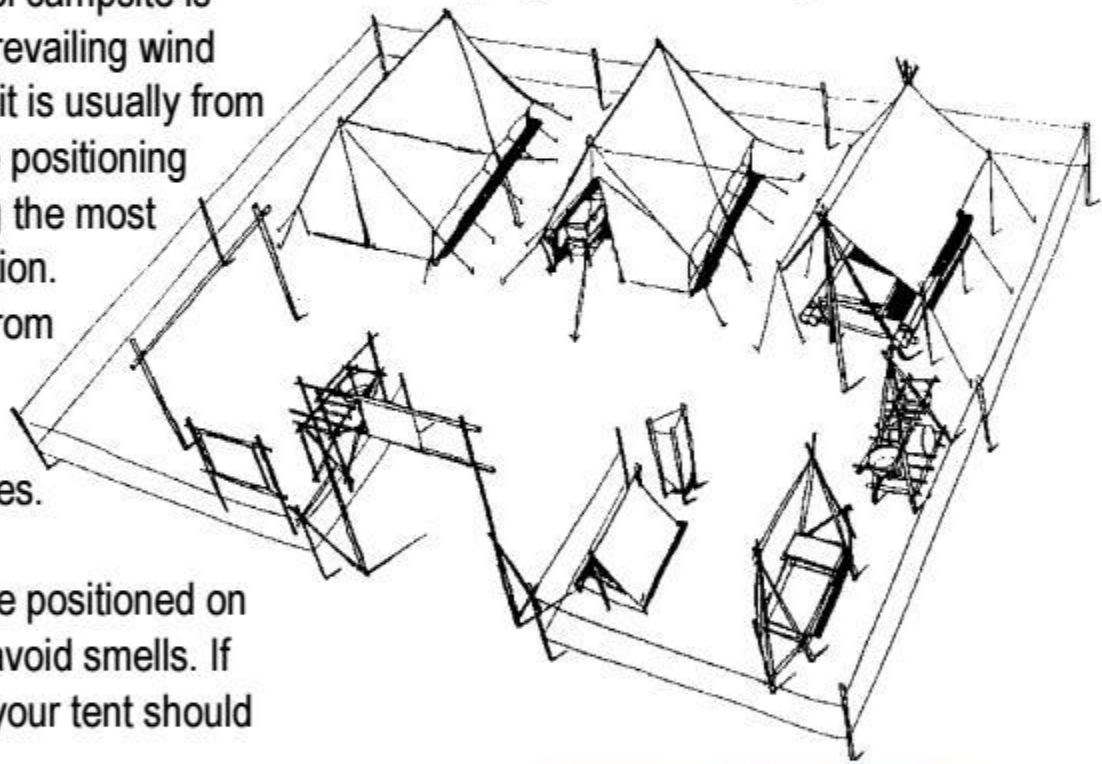
Remember, to leave nothing but your footprints, and thanks.

Campsite Layouts



The layout of a Patrol campsite is determined by the prevailing wind direction, (in Ireland it is usually from the South West), the positioning of the fire area being the most important consideration. Smoke and sparks from the fire should be blown away from tentage and woodpiles.

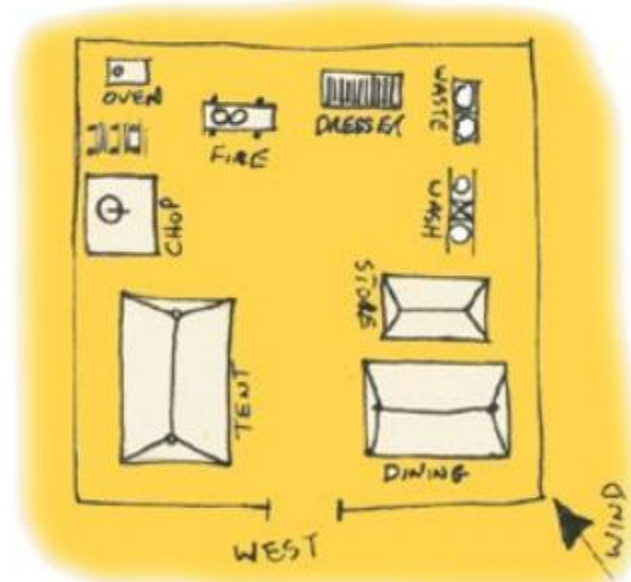
A Gateway can be erected as the formal entrance to the site rather than the 'hopping over' site railings.



ROOM OUTSIDE

Waste bins should be positioned on the leeward side to avoid smells. If possible the rear of your tent should face into the wind.

Patrol sites are usually railed off (sisal fence) to show the extent of the site. This is important as it contains the area and aids in cleaning up and maintaining the site.



You should draw up a site map before you create your site using wind direction as your guide to place the areas on your site.

Tents for Standing Camps

The tentage required for a standing camp is normally heavy canvas tents such as icelandic tents, small marquees and dining shelters. These tents are designed for long term camping and will withstand the rough treatment and the rigours of Patrol camping. Small dome tents are not usually suitable for long stay camping due to their small internal space and the lightweight materials used in their construction. However, if you have a mixed Patrol of boys and girls you may have a number of dome tents in place of an icelandic tent.

In general a dining shelter is not erected for a weekend camp, rather it is used for camps in excess of 3 days. Small marquees are normally used by Leaders, as store tents or as back up in case of bad weather.



Care of your Tentage

Your tent is your home for the duration of the camp and should be treated as such. A tent properly pitched and a routine of care and maintenance will ensure that it performs well when it is required to - usually in severe weather conditions.

Some points to remember

Keep your tent neat and tidy at all times. When you rise in the morning, sleeping bags should be left out to air for a short period of time, then taken into the tent and rolled up. All clothing should be placed in your rucksack.

Each morning the walls of the tent should be hung up and the doors opened to air the tent.

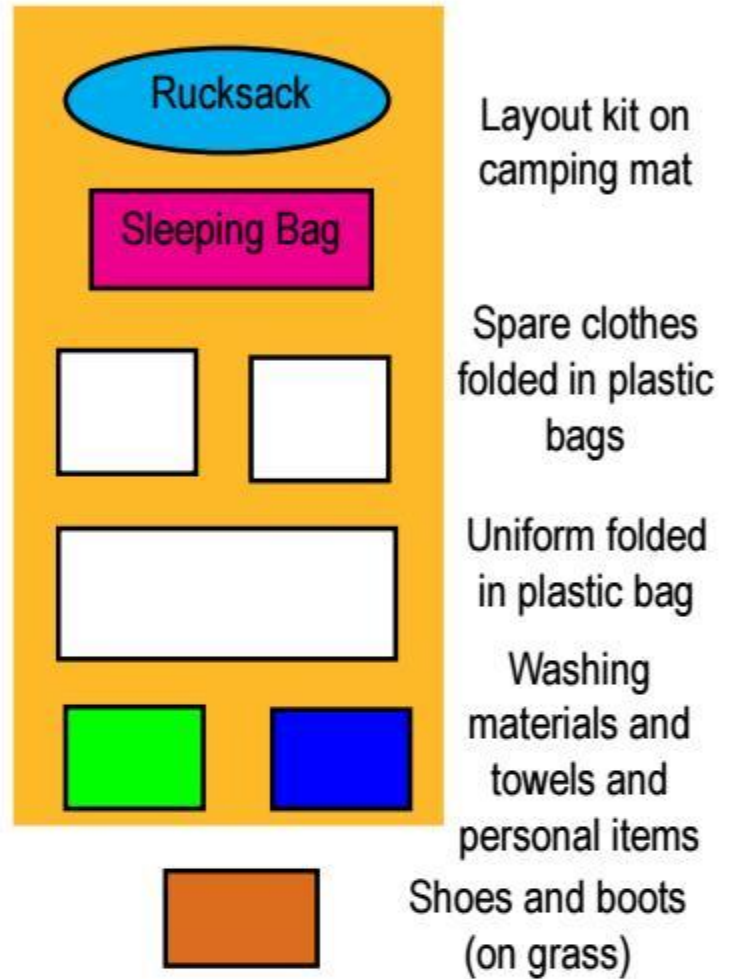
Heavy canvas tents react differently to nylon tents. Canvas is a natural material and when it gets wet it shrinks. Last thing at night, or if rain is suspected, the guys of the tent should be slackened. In the morning when the tent has dried out they can be tightened again.

The groundsheet should be turned back at the doorways during the day to prevent muck and dirt being brought into the tent. At night or in bad weather you should ensure that the sod cloth is placed under the edges of the groundsheet and not projecting out under the walls of the tent. This will prevent water entering the tent. The groundsheet should be removed from the tent every second day on long camps to allow the grass to breathe and prevent the grass under it from dying.

The tent should be pitched in such a way that the doors can be closed easily, using the loops provided. Sometimes it will be necessary to dig a small hole so that the tent pole can be dropped. This is done in the case of uneven ground, to allow the door flaps to be closed properly.



Kit Layout for inspection



Lighted candles should not be used inside the tents and cooking on stoves should be avoided unless weather conditions are extreme. If cooking inside the tents is necessary, it should be done with the utmost care, with the stove positioned close to the door and the door flaps open.

At night, tidy away dirty clothing in your rucksack and arrange fresh clothing at the top of your rucksack for the following day.

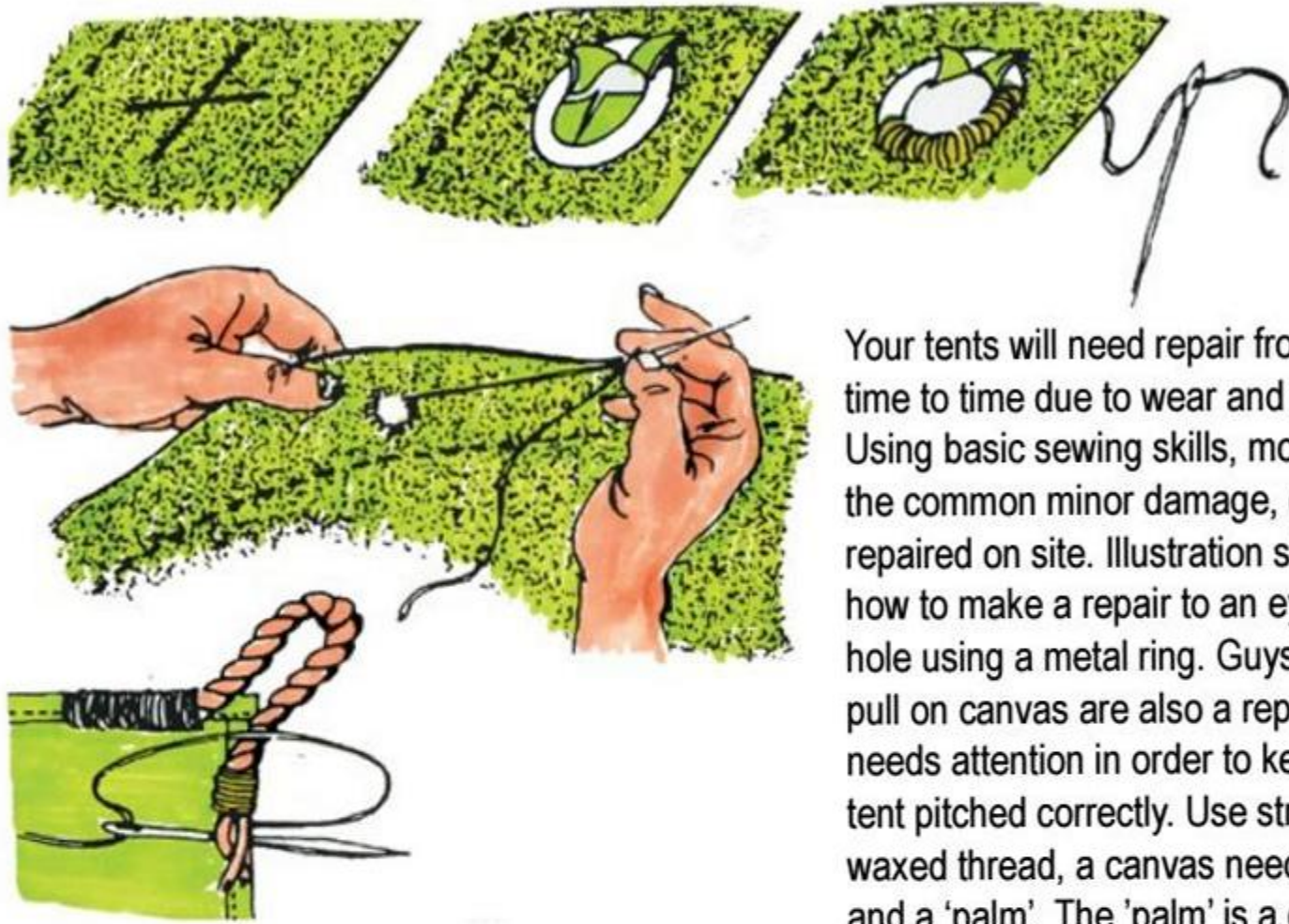
At night a tent should not be fully locked up to the extent that no fresh air can get into it. Leave a number of the door loops unlocked near the top of the door, perhaps using a small stick to keep the canvas apart, so that air can enter the tent freely.

Any damage to tentage should be reported to the Troop Quartermaster so that repairs can be undertaken. Small repairs should be undertaken immediately to prevent further damage due to wind or strain on the damaged part of the tent.

When breaking camp ensure that all tents are thoroughly dry before packing. If it is necessary to pack tents when wet, ensure that they are allowed to dry out properly on your return home. Pegs should be cleaned before packing and a note made of any damage to tent, or pegs that have been broken. The Troop Quartermaster should arrange for repairs to tents and replacement of pegs before the tents are packed away in the store. This will ensure that your tent is in perfect condition the next time you go on camp.



Tent repairs



Your tents will need repair from time to time due to wear and tear. Using basic sewing skills, most of the common minor damage, can be repaired on site. Illustration shows how to make a repair to an eyelet hole using a metal ring. Guys which pull on canvas are also a repair that needs attention in order to keep your tent pitched correctly. Use strong waxed thread, a canvas needle and a 'palm'. The 'palm' is a device which allows you to push the needle through the canvas with ease and safety.



Canvas is sewn in a number of ways as shown. These folding seam methods give strength to the join and prevent water seeping through the joint.

Kitchen Area

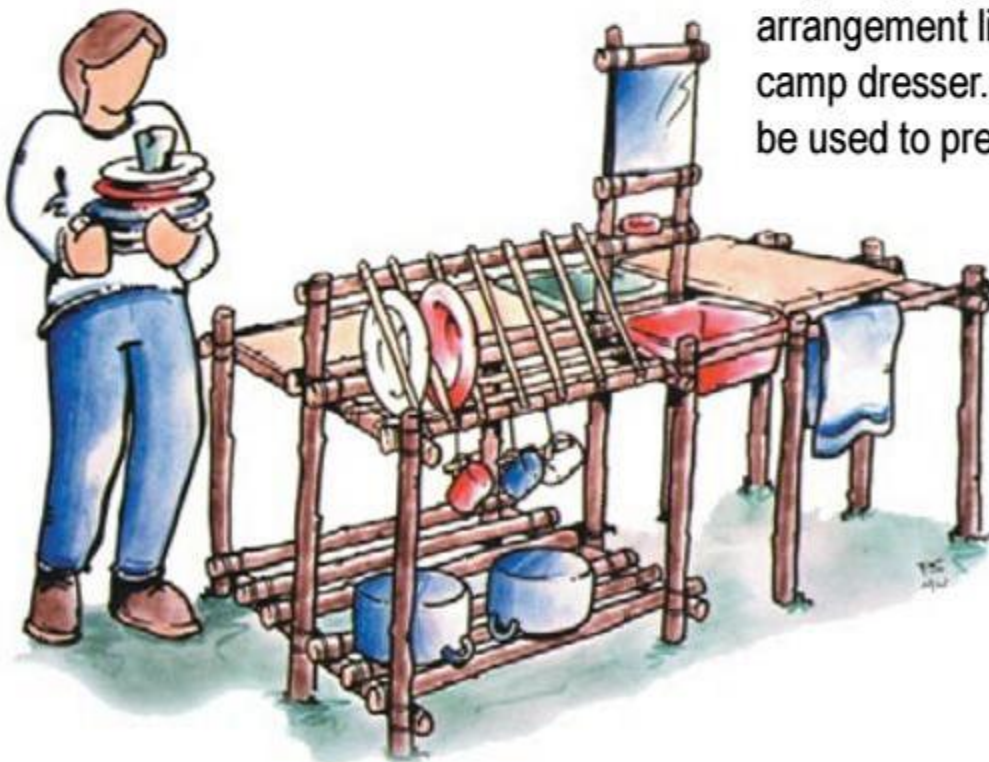
The kitchen area of your site is the place where food is prepared for cooking. This area is situated close to the fire and the dining areas.

Cooking on camp should not be an opportunity to abandon cleanliness and hygiene but rather an opportunity to display your cooking skills in the open air- anyone can prepare food with ease in their home kitchen. A preparation table and a dresser are required to allow you to do this task with ease. Basins and water should be at hand to clean vegetables and utensils.

Utensils such as billies, pots and pans as well as plates, sharp knives, mixing spoons and bowls need to be at hand much as they are in your kitchen at home.

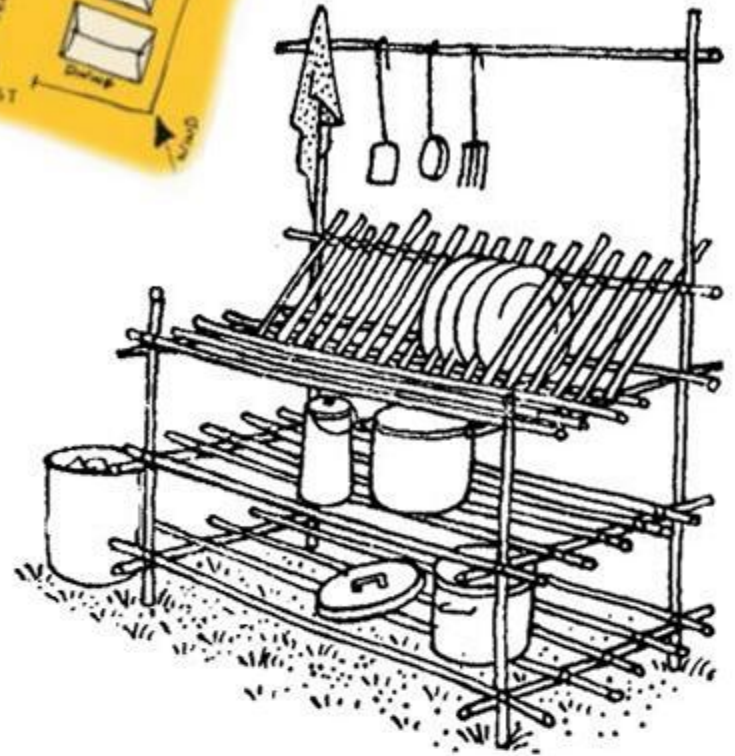


Some simple and more advanced gadgets are illustrated to provide examples of the type of structures you can build in your camp kitchen.



It is better to have a flat solid table top on your gadget rather than an open pole arrangement like that on a traditional camp dresser. Chopping boards should be used to prepare vegetables and meat

and these boards should be cleaned thoroughly in hot water after use. Chopping boards should be part of your Patrol equipment. You may wish to have a small box containing such items as salt, pepper, herbs, and spices commonly

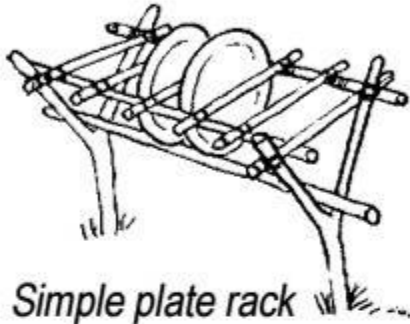


Traditional Camp dresser design

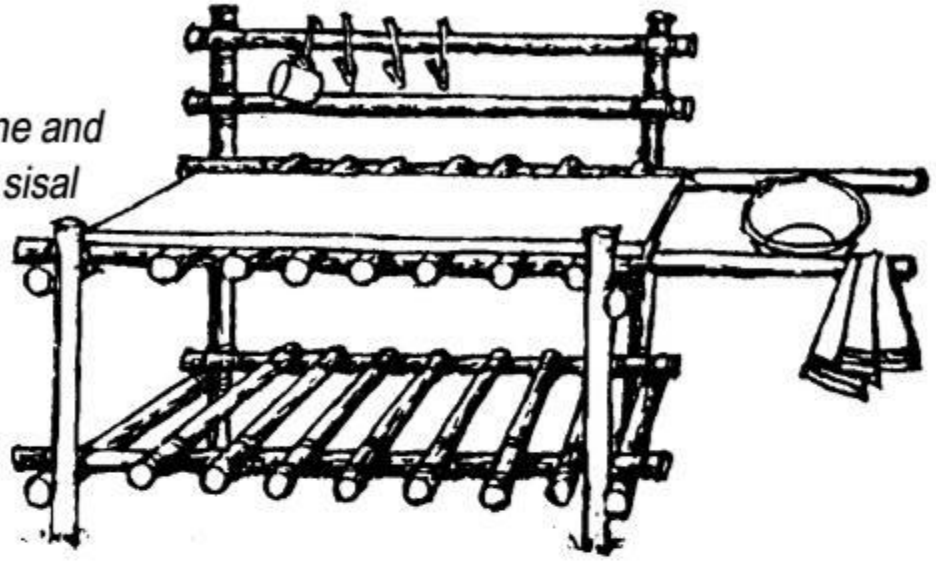




Plate rack detail using bamboo cane and elastic bands as well as traditional sisal lashings for main structure



Simple plate rack



Simple Kitchen table. Billies stored underneath



Free standing pot and plate structure using tripod construction



T- cloth clothes line using bamboo



Plate detail - using bamboo

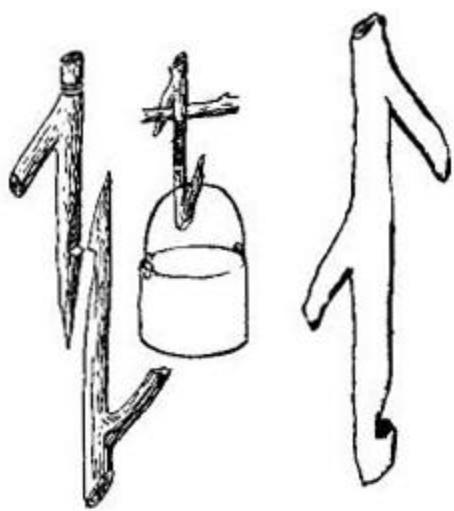


Dresser detail - hanging cups

used for seasoning, at hand on your table/ dresser when preparing your food. A basin should be provided in your kitchen area (other than the basin used in washing area) as well as wiping cloths and drying cloths.

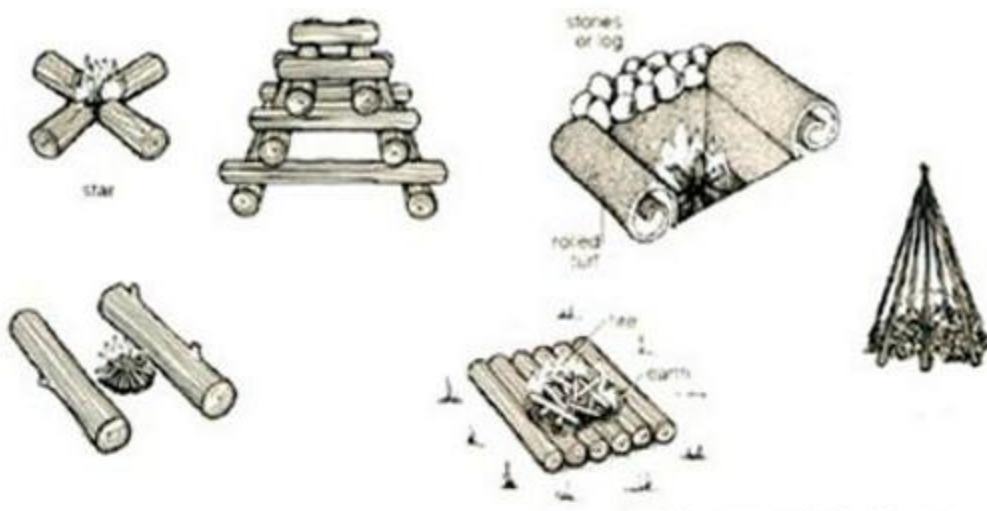
A good idea for Patrols is to construct a fold down table top made of two pieces of wood hinged in the middle, that can be placed in your Patrol box. It is also a good idea to use bamboo garden canes, cut to size to make such things as plate racks.

Strong elastic bands are excellent for fixing these bamboos to a stronger frame of larger spars. The disposal of waste - water, vegetable and wrapper waste - (see Waste Disposal) also needs to be considered in the design of your kitchen area. The waste disposal gadget can form part of your table/dresser or be a separate gadget. Only make gadgets that are practical and functional in your kitchen area.



Pot hooks

Ground fires can damage the ground. If you have to make a fire on the ground then remove the sod and prevent the fire from spreading by using rocks or logs to surround the fire area.



Mound fire - place a fire proof cloth or heavy duty tinfoil on the ground and build a mound of clay at least 150mm high.



Hot Water Boiler



Hot water boilers are an excellent idea for a standing camp. The boiler and oven shown have been constructed from old beer barrels, you can also use other containers. Water is poured into the funnel that delivers water to the bottom of the boiler and pushes the hot water to the top. Hot water can then be poured from the tap mounted on front panel.

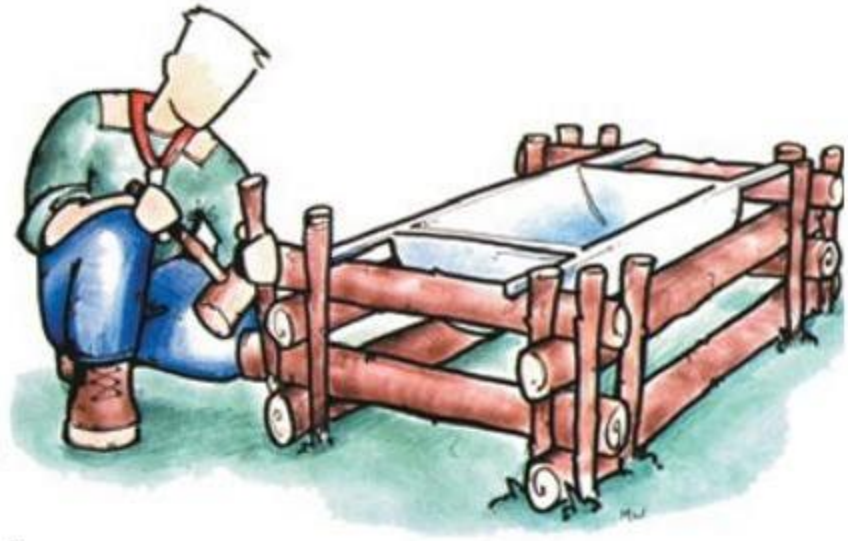
FIRE PRECAUTION



Fires can flare up if left unattended and sparks may travel on a gust of wind, therefore it is a wise precaution to set up a fire point on site. Have small fire extinguishers or fire blankets nearby in case of emergency.



Building an altar fire

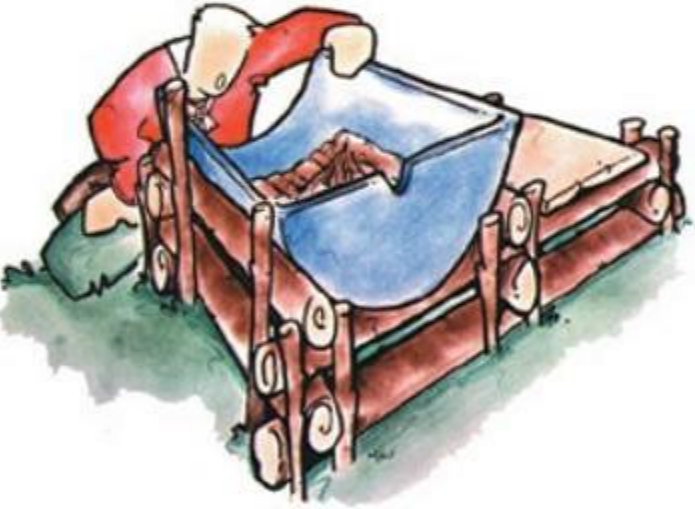


Fires built directly on the ground are normally discouraged due to the damage that is caused to the ground as a result of burning. Scouts are encouraged to construct altar or raised platform fires which are more environmentally friendly. Altar fires are also easier to cook on and because of their size result in the burning of smaller and more controllable fires.

There are many possible designs and the guiding factors in building an altar fire are:-

The platform must be stable and solid. The platform is made with timber or stones and a metal fire box.

The fire box can be made using a cut down barrel or a metal plate. You can also make a fire base using mud and clay on a wooden base.



It is a good idea to cover the metal fire box with a layer of mud and clay to prevent heat transfer to wooden structure.

The platform should be high enough to cook safely and in comfort.

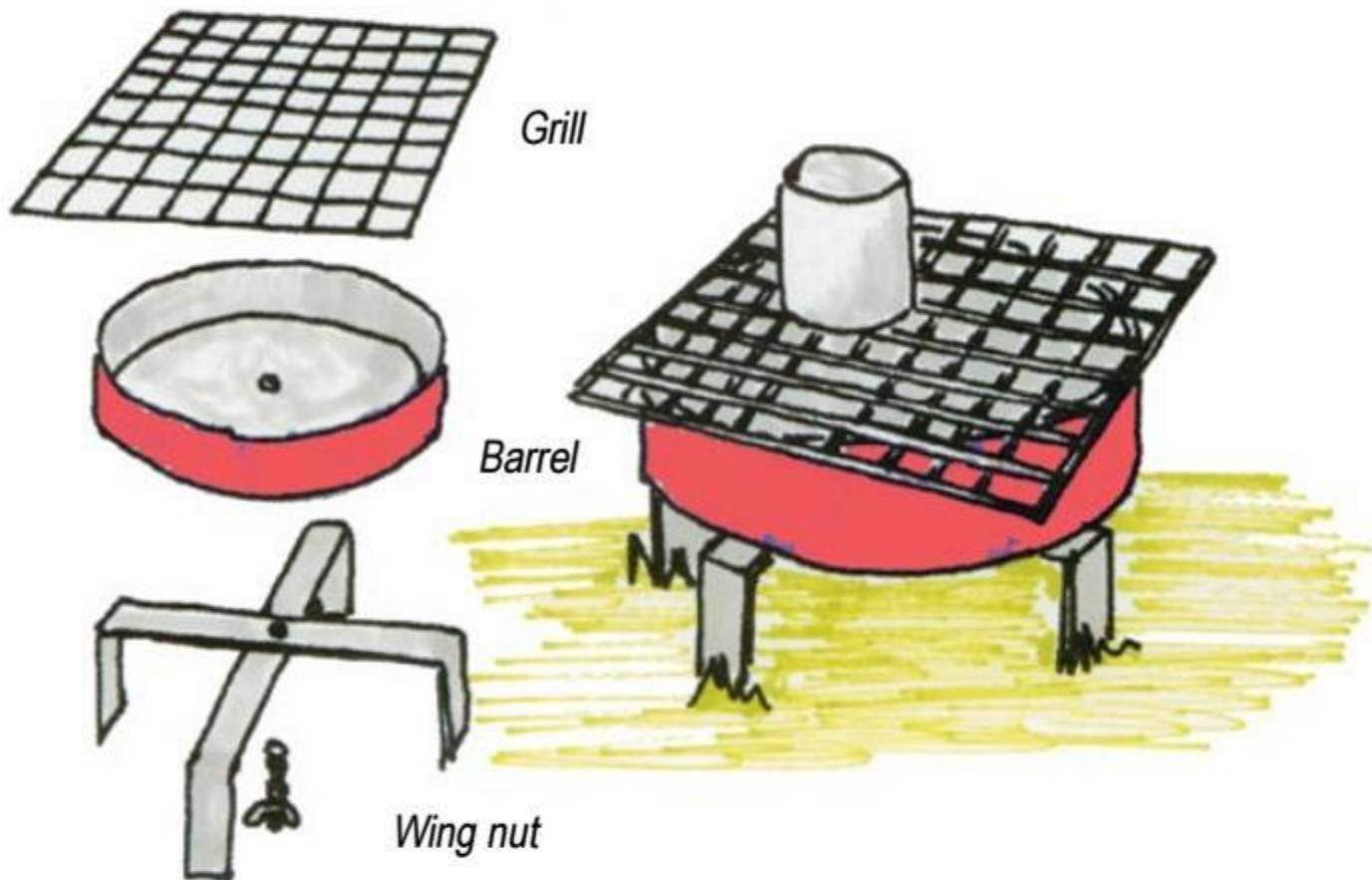
The timber used in the construction of the fire can be protected by wrapping the exposed parts with tin foil.



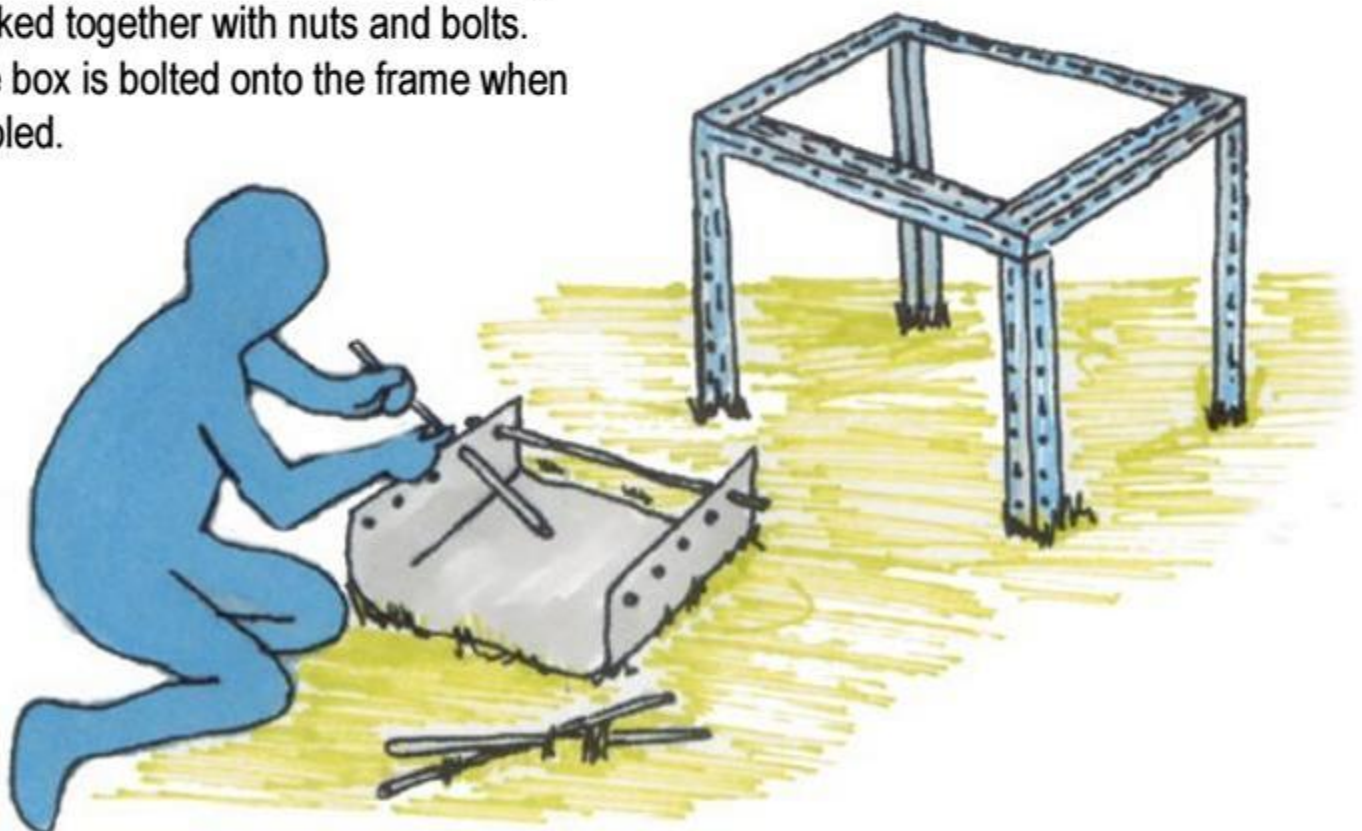
Fold down altar fire

This fold down altar fire was made from the bottom of a barrel that has been cut down. The sides of the barrel are 15 centimetres high. The legs are constructed from steel bars which are bent to form legs

which can be pushed into the ground. A wing nut and bolt are used to join the legs and barrel together to form the fire. A piece of wire mesh is used to form a grill



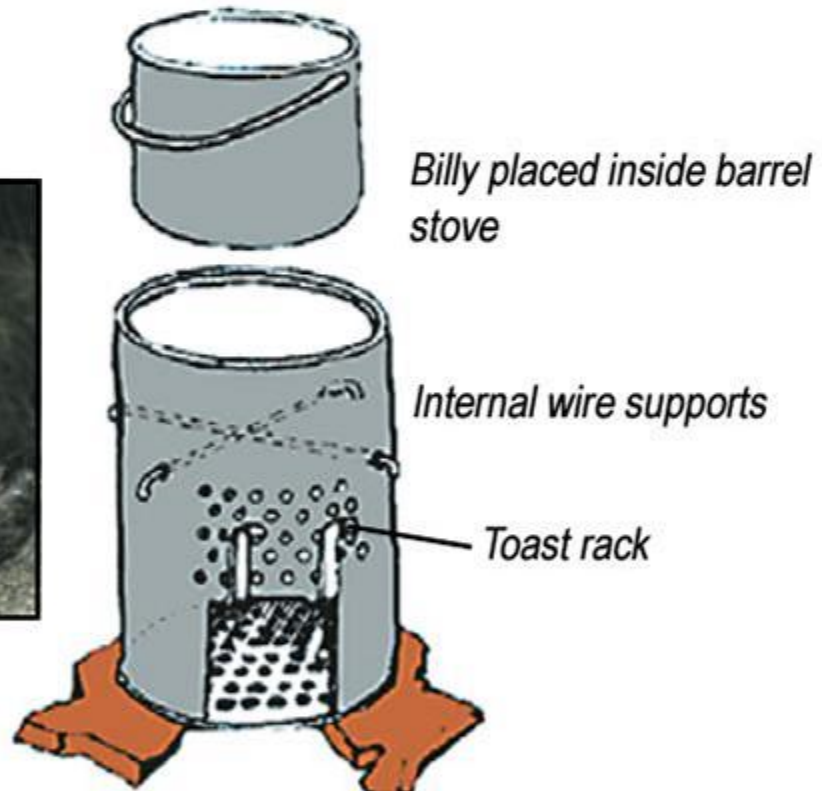
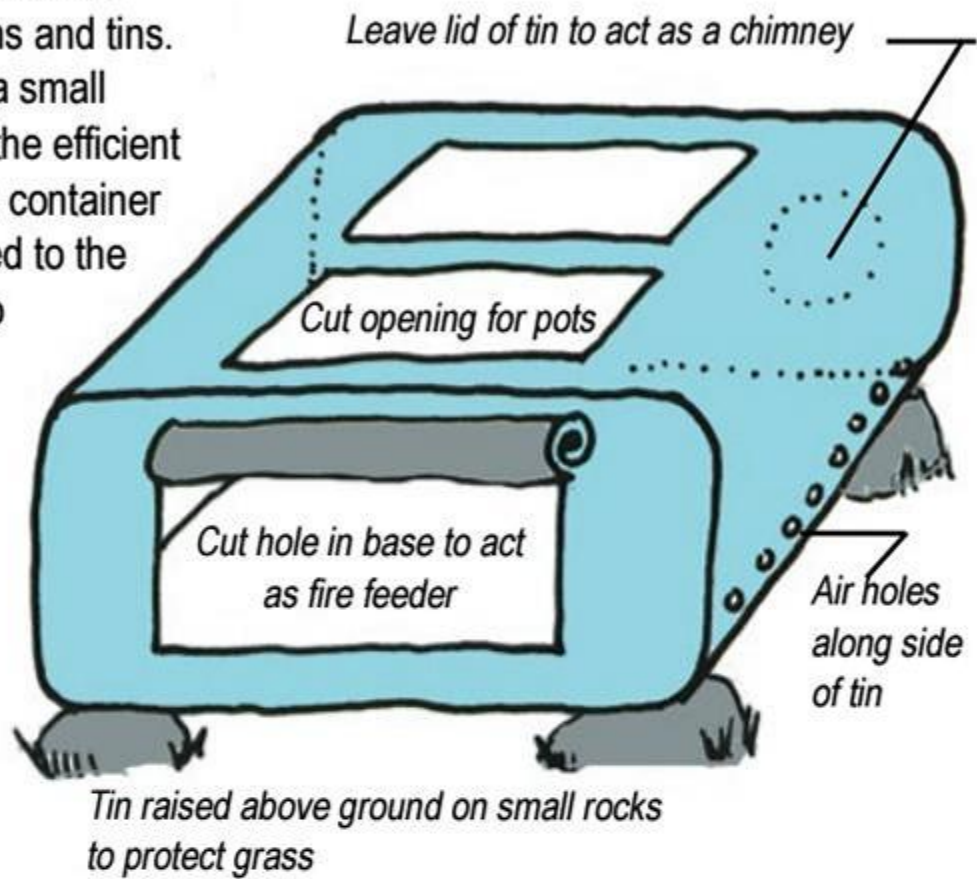
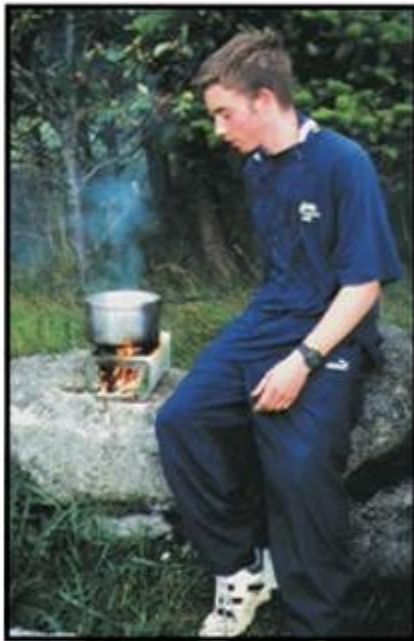
This fire is made from a piece of bent metal plate. Holes are drilled near the top of the plate in which metal rods are placed. The rods from the cooking grill. The base is made from shelving angle bars and locked together with nuts and bolts. The fire box is bolted onto the frame when assembled.



Conservation Stoves

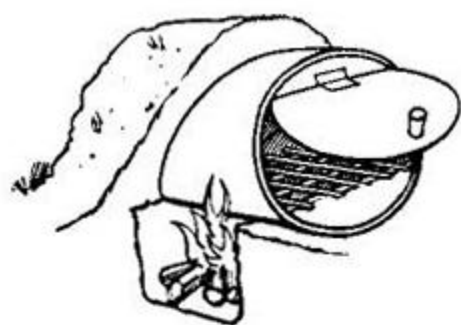
Many designs are possible and two are illustrated, a 5 Litre tin and a larger barrel stove. Tins should be thoroughly cleaned before use.

Simple fuel efficient stoves can be made easily using old drums and tins. These stoves require only a small amount of fuel because of the efficient way the fuel is burned. The container channels the heat generated to the pot rather than being lost to the surrounding air.

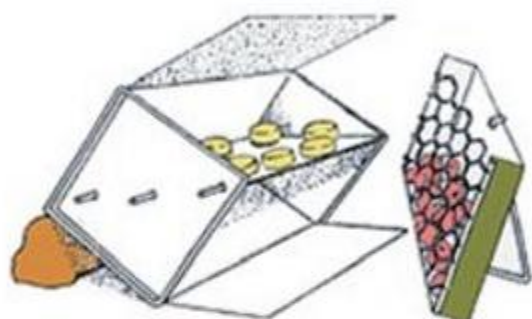


Bucket Stoves

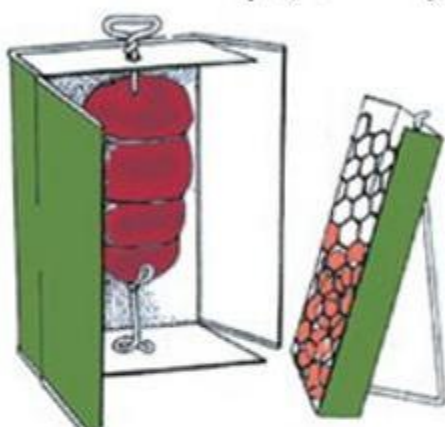
Camp Ovens



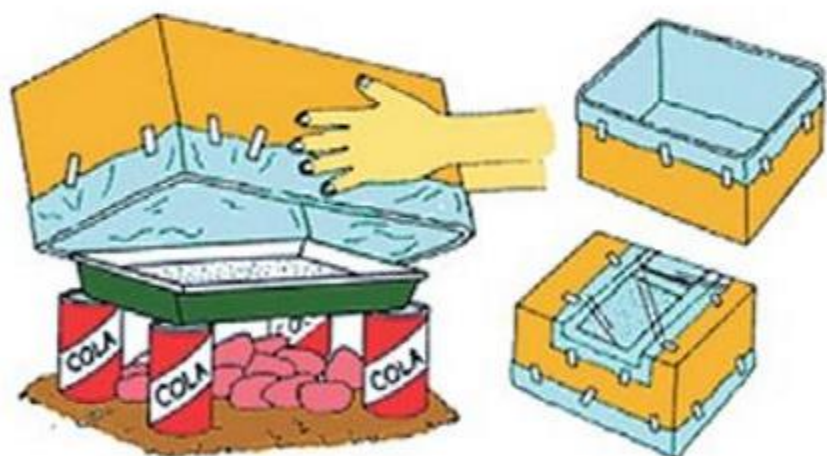
Traditional clay oven - barrel bridges fire pit, chimney constructed of tin cans



Reflector stoves made from oil drums and cans or sheet metal

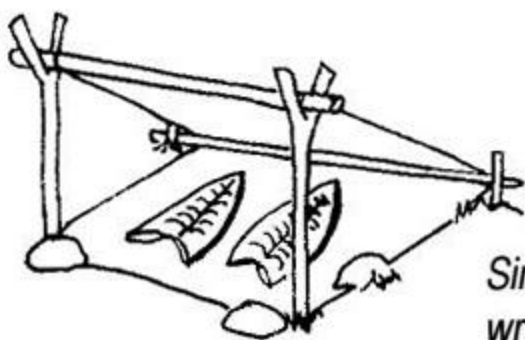


Turkey bag stove works on the same principle as cardboard box stove and uses charcoal



Cardboard box stove.

Line a box with tin foil. Leave a small gap under edge of box to allow air in. The average temperature of an individual coal is 20 degrees. Place inside the box the number of coals required to make up temperature as stated in recipe.



Simple reflector stove using foil wrapped around a simple frame

Chopping Area

The chopping and cutting area is a controlled area on camp. Only one person can work in safety within this area due to the nature of the work. Axes and saws will be in use. Onlookers should be discouraged and be a minimum of 3 axe lengths away where they are not in danger of being injured by tools or flying woodchips.



Before work commences in the area the ground should be cleared of any branches or other obstructions.

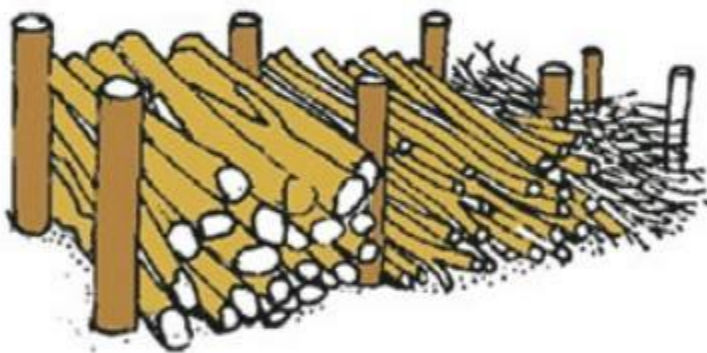
Any loose clothing or attachments such as lanyards or neckerchiefs should be removed.

Always wear strong boots and never sports shoes or trainers.

Check all tools before use to ensure blades and heads are secure and safe to use

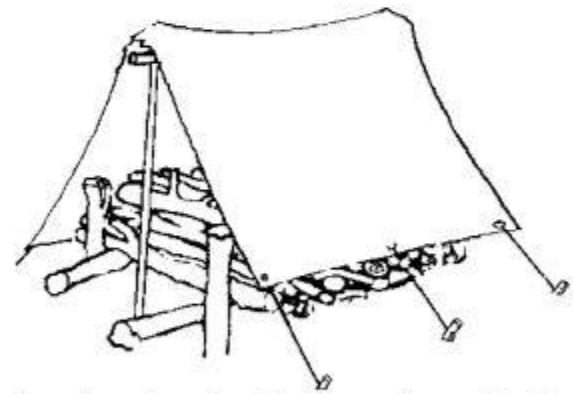
Use a chopping block

It is a good idea to place a piece of plastic on the ground to aid the clean up of wood chips and sawdust.



Simple and tidy wood pile with timber to a manageable size and graded for use.

Scout at work in chopping area. Note neckerchief tucked away safely, ground sheet and use of chopping block



Construct a simple shelter using plastic sheeting or piece of old canvas to keep your firewood dry.



Saws

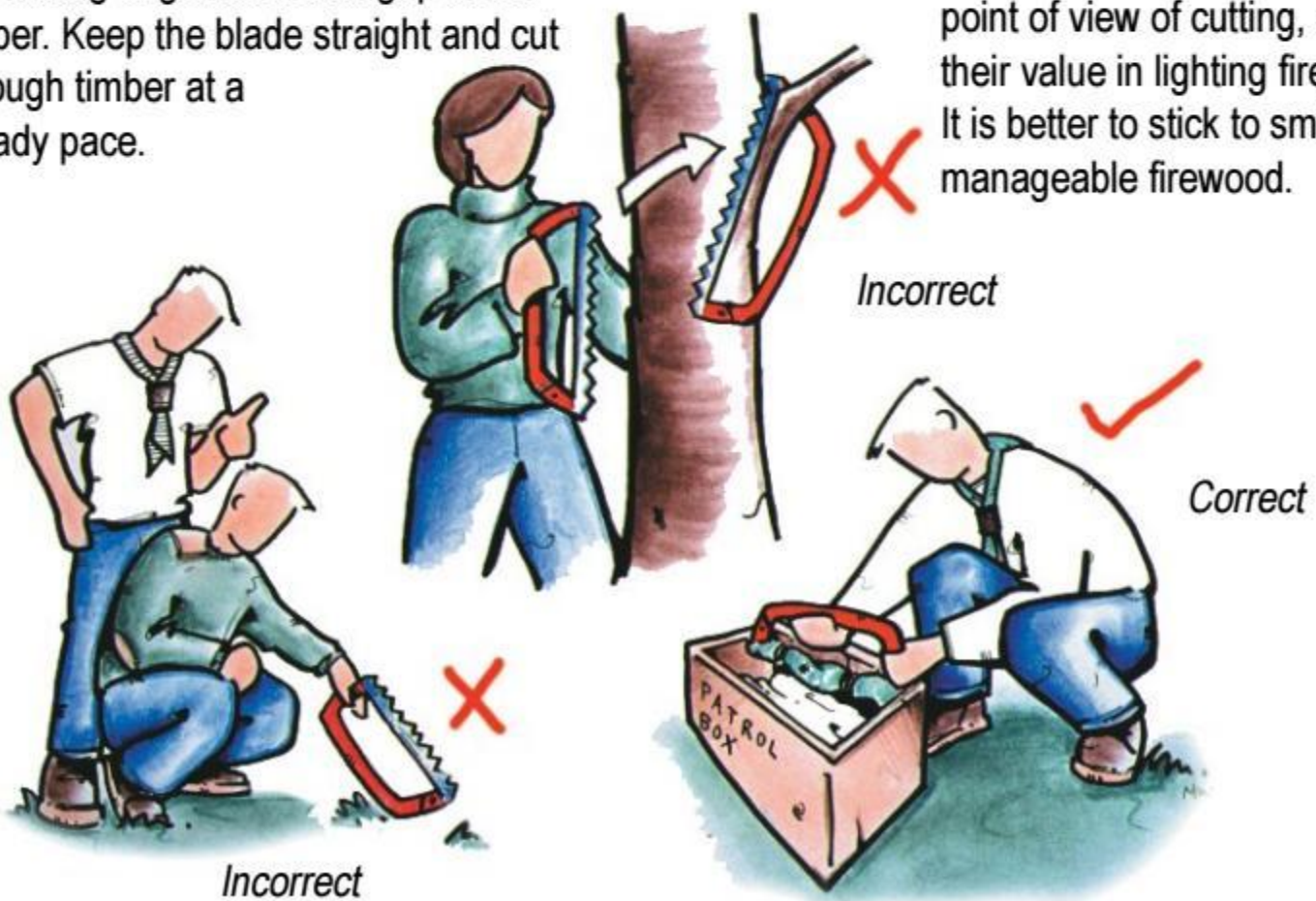


The cutting of timber on camp is best done with a saw. Although it does not have the same appeal as an axe, a saw cuts wood with greater economy. The bush saw is ideal for working on small timber in camp because it leaves no wood chips.

Some rules to remember

When a saw or axe is not in use it should be put away safely. An axe should be securely placed in a chopping block. The saw should be masked and left in a safe place.

When cutting timber start off slowly until the cutting edge has a firm grip in the timber. Keep the blade straight and cut through timber at a steady pace.



It is a wise precaution to wear a pair of industrial gloves to prevent serious cuts if the saw blade should slip.

The construction of a saw horse for holding logs steady when cutting is another safety measure worth considering on long term camps.

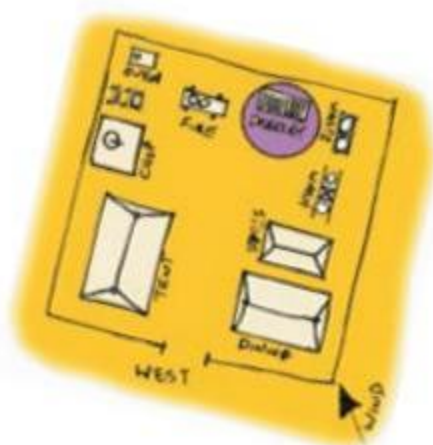


When a saw is not in use or being put away after camp, remove the blade, wrap it in paper or sacking and secure it with sisal.

A small bush saw is just as good as a large saw and easier handled by most Scouts. In general we should not be cutting large diameter timber in camp, pioneering timber being perhaps the thickest. The cutting of large logs is not advisable, both from the point of view of cutting, and their value in lighting fires. It is better to stick to small, manageable firewood.

Dining Area

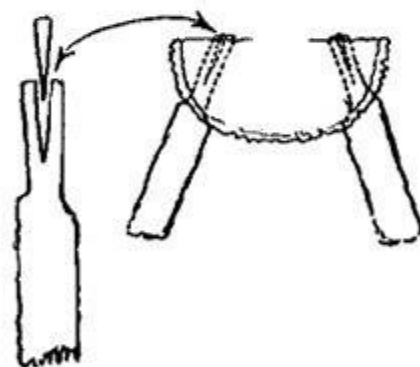
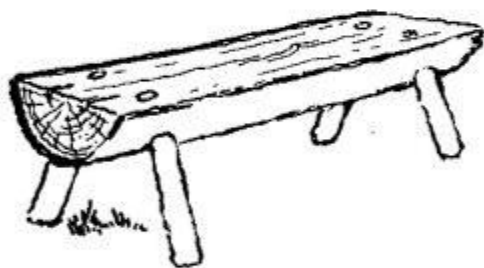
A table and chairs are necessary gadgets for long term camping. On a weekend or lightweight camp a simple arrangement of logs or rocks can provide a dining area. However in a standing camp situation a dining area is needed on your site. Some ideas are presented here, and there are many more possibilities. Some dining shelters have their own poles so the table and chair arrangement needs to be created independently of these poles. The examples show dining shelters that are constructed using pioneering spars with a canvas covering.



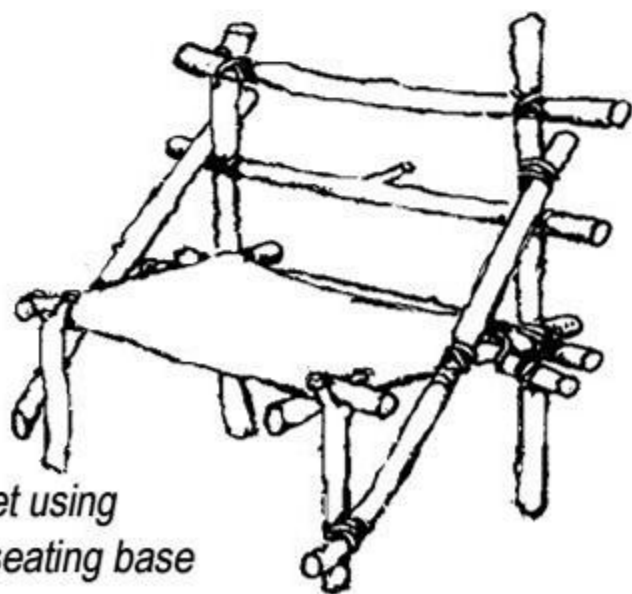
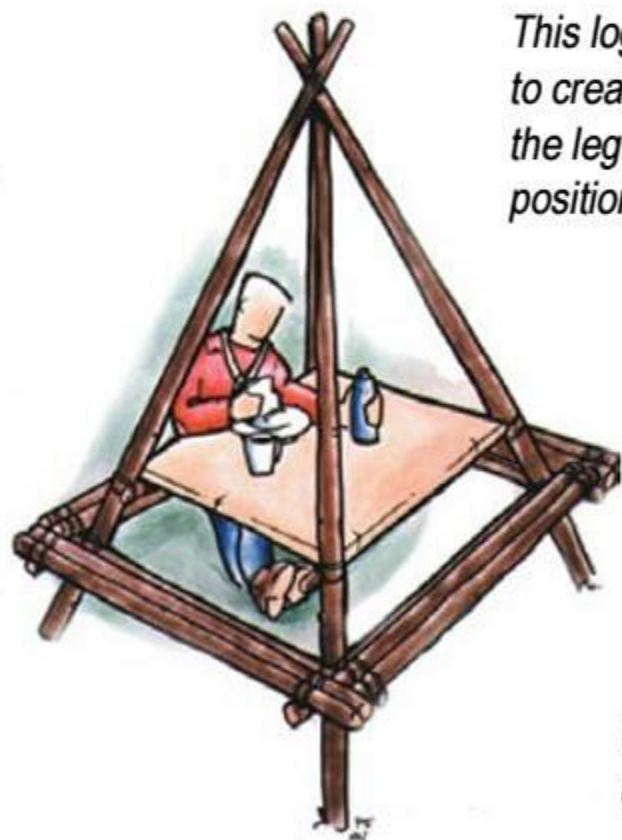
The use of side poles at the corners of the canvas sheeting can provide more headroom inside the shelter.

Within your dining area you may create a number of gadgets to store plates and cutlery. (see examples)

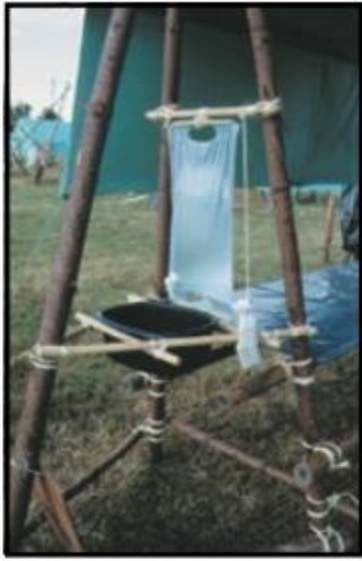
ROOM OUTSIDE



This log bench is constructed using an auger drill bit to create holes. A split or cut is made in the peg end of the leg. A wedge is driven into the cut, after the leg is in position. (see Scout Stuff Chapter)



Chair gadget using canvas as seating base



Wash stand built in tripod section of shelter



Plate, cup, knife and fork holder attached to ridge pole

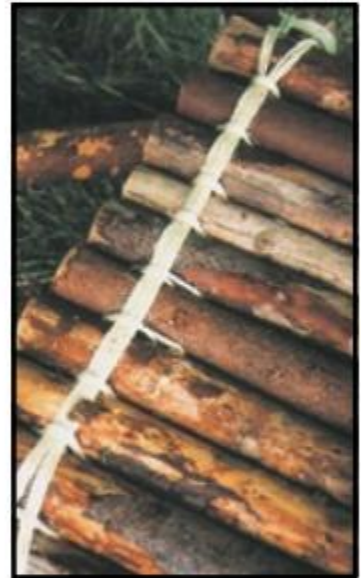


Table top created from bamboo cane



Wash stand and plate holder created as an extension to shelter

Alternative table top construction using logs. Note binding method



Simple storage solution for cutlery



Simple mug hanging solution



Alternative to hanging log - placing log in centre of table

Storage

On camp the safe storage of foodstuffs is very important. All foodstuffs should be placed in secure containers, in particular such items as sugar, cereal, bread, in fact any food item that does not have a resealable packaging. In general it is better to buy perishable foodstuffs such as milk, meat and bread on a daily basis.

It is not a good idea to store foodstuffs in your sleeping tent so a small store tent needs to be erected to store foodstuffs, and camp equipment. The tent should be laid out in an orderly fashion so that it is easy to find what you want. It is the job of the Patrol quartermaster to keep the tent in order.



Camp Cooler

Billy contains salt water in which the water is drawn from billy onto the muslin by capillary action. Evaporation process causes the temperature inside the cooler to drop dramatically. Water needs to be replenished as required.

Billy is covered by (wet) muslin cloth to create cooler and tied at bottom with sisal.

Small shelves are hung by sisal to hooks which clip onto billy rim.

ROOM OUTSIDE



Some points on storage

All foodstuffs should be stored in sealed containers within a wooden box or other large storage box. These boxes should be raised off the ground.

All packaging should be disposed of and not allowed to clog up the store. Spillages should be cleaned up immediately so as not to attract flies and insects.

All fuels and lanterns should be stored outside the store under their own cover.

Never change gas cylinders or allow methylated spirits or other fuels to be filled from one container to another inside the store tent.

Don't use the store tent as a meeting place.

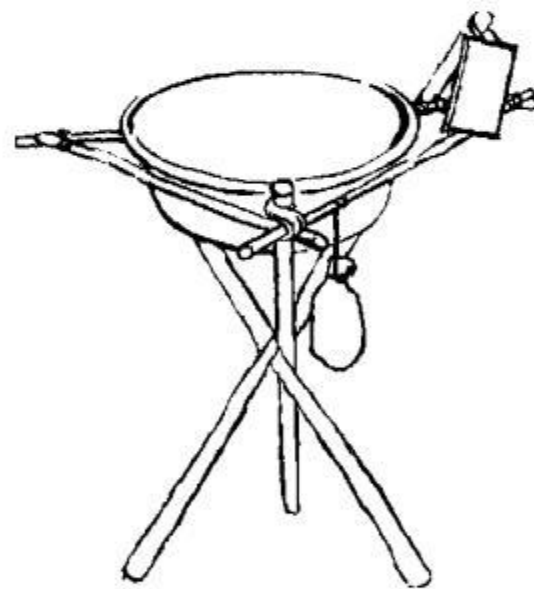
Wash Area



A wash area is needed on your site for health and general cleanliness, as well as preparing food and cleaning utensils. You may choose to have just one general wash stand or construct two, one for personal use - washing of hands at meal times, before preparing food etc., and one for general use.

on site then these should be used on a regular basis for general bathing and hair cleaning.

Living in the open exposes your foodstuffs to insects and wind borne dust particles even if they are carefully stored, as a precaution, food should be cleaned before



Basic washstand

Everybody on camp should wash every morning when they get up. This is the same routine as would be practised at home - face, hands, teeth and the combing/brushing of hair. Scouts should use their own personal towels and T cloths for drying plates etc. These can be placed on the Patrol clothes lines to dry out after use, before being put back in rucksack. If shower facilities are available

use. Likewise, all plates and cutlery should be cleaned properly after use, in hot water. Insects and indeed wild animals will be attracted to your site if food pickings are easily available.

Waste water from washstands should be placed in the waste water bin, for filtering of soap and food particles before disposal.

Waste Disposal



Camp incinerator



Waste and rubbish management on camp

Waste water filter system



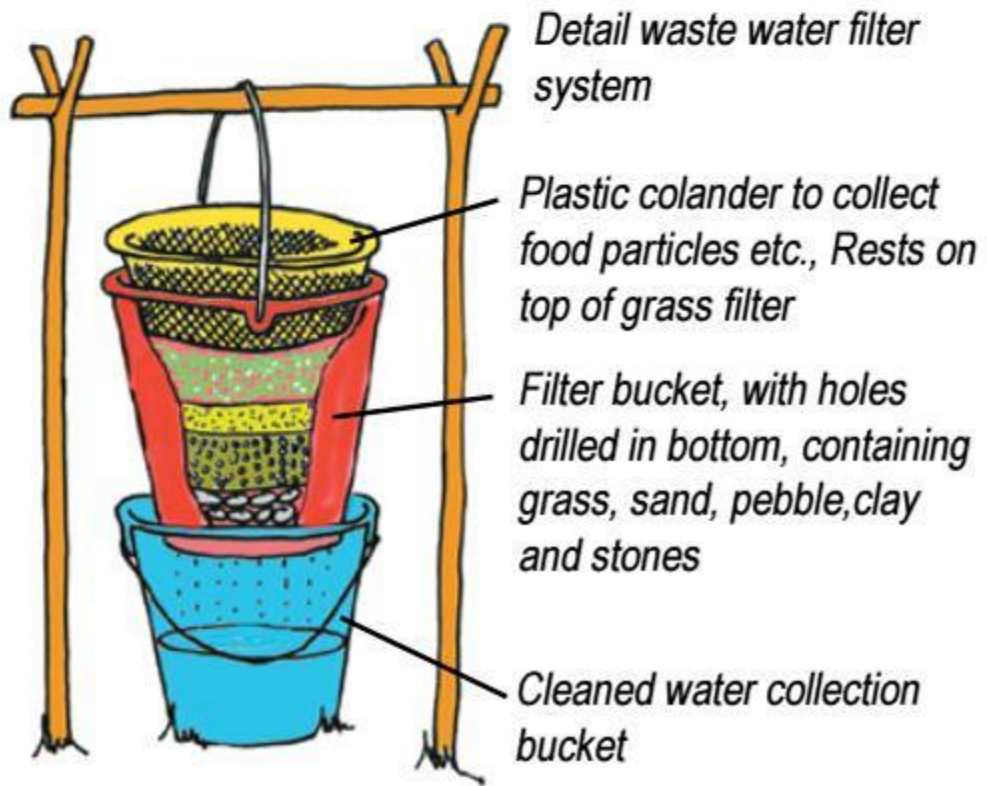
Once you start to live on camp you will generate waste of all kinds -water waste, wrapper waste and bodily waste. Each is dealt with in its own special way.

All paper and food waste should be burned on the Patrol fire or in a special incinerator as shown, constructed from an old barrel. Tin cans and containers should be rinsed out, burned and bashed flat and then placed in a rubbish bag, recycle if possible.

Waste water needs to be filtered before it is returned to the earth, to remove food debris, soap and grease. This filter system is constructed above ground and the filter water collected before spreading it over waste ground away from the site. The filter system will contain grass or straw to trap the particles and this must be replaced daily.

The above will be necessary on all campsites even if the campsite has a refuse facility on the site. Waste that is burned, bashed and bagged should be placed in the campsite bins for transport to the local dump, or recycling centre.

In the case of bodily waste, it is best to seek a campsite that has toilet facilities. However, in remote locations, while backpacking, or on remote mountainside, you should be aware of procedures.



Latrines

If the campsite has no permanent toilet facilities then it will be necessary to construct latrines for the duration of the camp. The latrines are sited on the leeward side of the camp and a reasonable distance from the site. A small toilet tent with a chemical toilet is the ideal.

The condition of this toilet tent will determine its use. It should be clean and private and have washing facilities available outside the tent.

Dig a dry pit (100cm X 30cm X 60cm deep) line with stones or pebbles, near to the toilet tent for wet waste. Have a small trowel nearby so that some soil can be thrown into the pit after each visit.

Construct a wash stand, with water and soap provided for hand cleaning.

The toilet on camp is different from that at home. Special chemicals have to be mixed according to instructions and placed in the toilet container to control smells and act



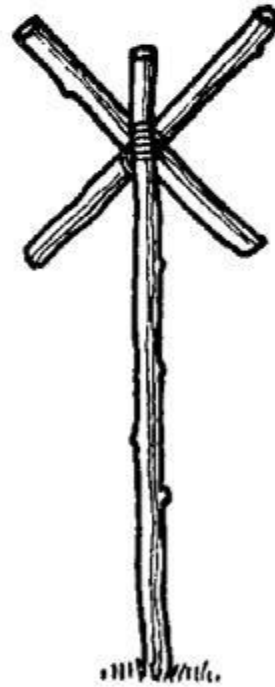
Toilet tent and chemical toilet

as a disinfectant. Each day the contents of this container must be emptied into a pit (100cm X 60cm X 60cm) especially dug for this purpose. The container should be cleaned with water and fresh chemicals mixed and replaced. The pit should be marked with a foul ground sign to warn other campers.

This is not a pleasant job but it should be treated in a serious manner and must be done correctly to prevent the spread of germs and infection on camp. The use of masks and rubber gloves, thoroughly cleaned in disinfectant afterwards, can make it easier.



If you are on the trail you need to dig a small cat hole latrine. A small trowel is brought in your pack for this purpose. Dig hole at least 150mm



Foul Ground sign

On a Troop Camp, it is normal to appoint a Duty Patrol to carry out a number of duties on camp each day. This can include the cleaning of toilets. The Patrol are assisted in their duties by a Scouter.

PATROL EQUIPMENT

Tentage

There should be enough tentage to accommodate the Patrol

Sleeping tents – Icelandic's or Domes

Store tent

Dining shelter

Tarpaulin sheet

Pegs, guys, poles, groundsheet and mallet

Patrol Box

Four basins – washing and food preparation

Buckets & plastic colander – for waste water gadget

Bucket – two for general use

Water container.

Gas Stove and gas cylinder.

Meths Stove and fuel.

Axe and saw.

Lantern – spare gas cylinder, mantles or batteries.

Muslin or nylon netting for food storage.

Small tool box

Hammer, pliers, hacksaw, vice grips, sharpening stone.

Cleaning

Mirror, shoe polish, cleaning cloths, pot scrubbers, sponge, plastic bags, toilet paper, washing up liquid.

Cooking equipment

Two chopping boards.

A selection of wooden spoons.

Whisk.

Ladle.

Large lifting spoon.

Large perforated lifting spoon.

Knives – chopping and cutting.

Egg lifter.

Tin Opener

Potato peeler.

Potato masher.

Sieve.

Colander.

Cooling rack - metal.

Two plastic mixing bowls.

Measuring cup and spoons.

Plastic containers - various sizes.

Selection of herbs and spices.

Salt and pepper shaker.

Two sets of billies.

A large pan.

A small pan.

Oven gloves.

Two baking tins.

Baking trays – camp oven.

Roll of aluminium foil.

Plastic table cloth.

Two large serving plates.

Tea tray.

Tea pot.

Eating

Table and benches.

Table top - if making gadget.

Altar fire base.

Safety

First aid kit.

Fire blanket.

Fire extinguisher

General

Rope and pulleys – for pioneering.

Rope and sisal – for gadgets.

Bamboo and elastic bands – for gadgets.

Patrol flag.

Note paper and pens.

Log Book.

Map and compass.

Mending kit.

Matches, disposable lighter, candles.