

HOBO STOVES

Making stoves be recycling cans
and scrap metal



LEAVE NO TRACE - MOUND FIRES



When we enter into the backwoods, away from direct contact with civilisation, we enter an area that is unspoiled - a natural environment.

Leave No Trace principles state that we should pass through an area and leave no trace of our presence. In a backwoods activity we will wish to camp and live with minimum equipment using what we find around us in the forest. Where we camp, light fires, cook and dispose of waste of all kinds is an important consideration.

In this resource we present many ideas for the creation of lightweight backpacking stoves using recycled cans and piece of metal. Most of the stoves will be small and work by placing them on flat stones. However, if you are considering placing them on rough ground it is a good idea to create a mound fire base to protect the ground

Mound Fires

Mound fires can be constructed on many durable surfaces without destroying the earth beneath it. A covering made of a fire blanket or heavy duty tin foil is placed on the surface. Then a mound of clay is placed on top on which the fire is built.

Ideally, when travelling on the trail or in a backwoods situation you will bring with you in your kit a trowel, some heavy duty tinfoil or flame proof cloth and a few small plastic bags. The fire is easy to construct - first choose a location, what you are looking for is a durable or scrub surface free of vegetation. The sandy or pebble banks beside a river are ideal.

Collect the clay, sand for the mound in the plastic bags and build a mound at least 150 mm high this thick layer of clay will insulate from the heat of the fire. The tin foil or cloth gives extra protect both to the direct heat and from sparks and stray embers that might fall to the ground.

The size of the mound circle should be wide enough to allow for cooking utensils and the spread of coals from the fire.

When you have no longer a need for the fire the clay and embers can be returned to the source and spread around so that no trace exists of your presence

BASIC TIN CAN STOVE

An open fire or fireplace in our homes is not a very efficient use of fuel as most of the heat generated goes up the chimney or into our surroundings. In countries where fuel is in short supply they have adapted open fireplaces by containing the fire with a box. Traditionally these stove were built using clay. In modern times tin can and sheet metal have been fashioned to create simple stoves and ovens. The walls of the tin act to funnel and increase the heat of the stove and in doing so also burn other gases that are produced as fuel burns.

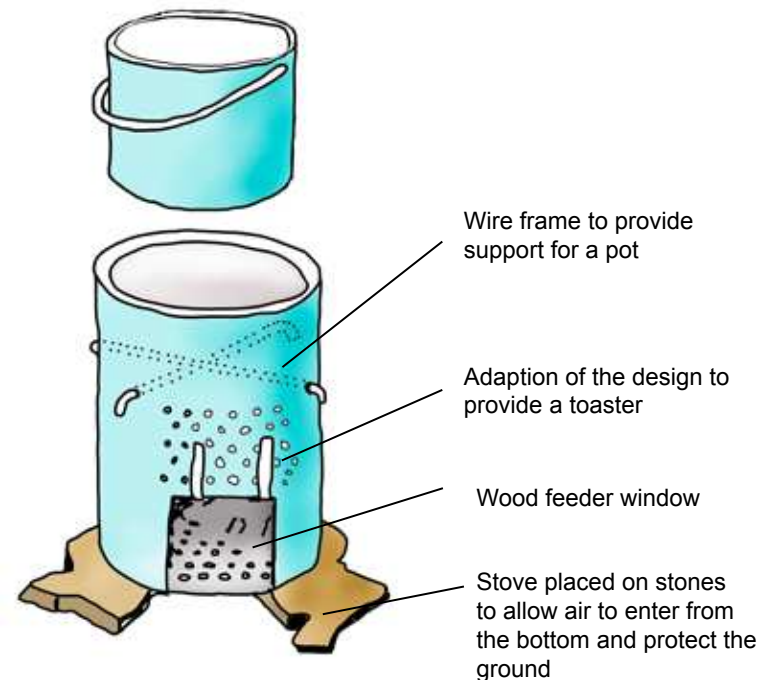
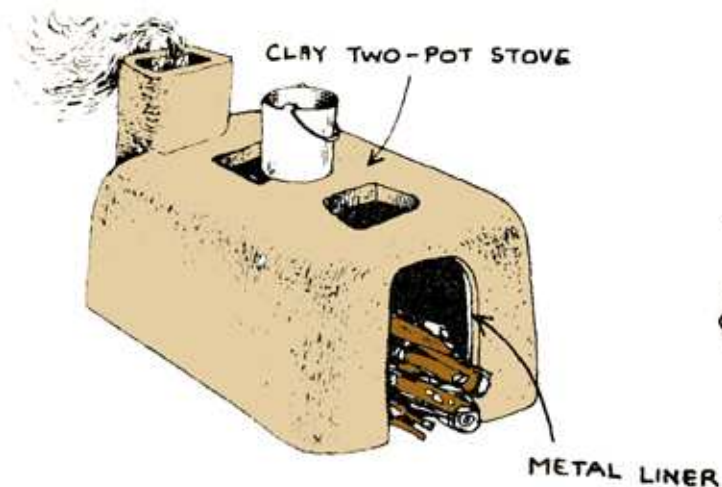

Today we have a vast array of tin cans available to be recycled into small and large camping stoves. The humble 'bean tin' is a good starting point for a small stove to perhaps heat water or warm up food. Bigger tins are better for heating pots and cooking bigger meals. The basic principle is to provide a 'window' in the tin into which fuel can be feed to the fire. Holes punched into the tin allow air to enter the stove and provide combustion. Steel rods, nails or metal tent pegs can be use to slot into the body of the stove to act as pot stands or to fix the stove to the ground.

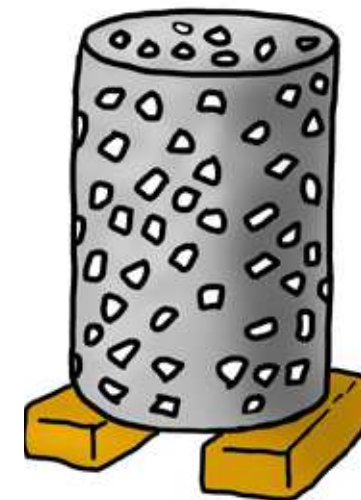

IKEA HACK STOVE

The simple cutlery draining container available in IKEA is a favourite item to be 'hacked' to make a wood burning stove. The basic design is to create a stand using some nuts and bolts and cutting a hole in the body of the container as a wood feeder.

Many other inventive cuts and attachments can be added to the basic model. Tent pegs can be slotted through the holes to act as pot stands. Tent pegs can also be fashioned to make legs and stands. The container can also be used as a wind barrier for use with alcohol stoves.

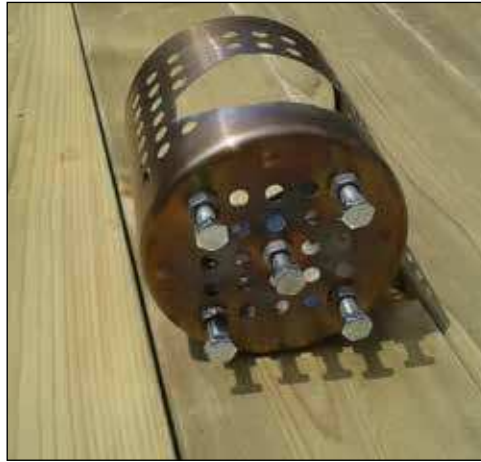

STEEL BOX STOVE

With some basic metal work skills it is possible to make a fold down fire box. The parts can be placed in a small bag and carried in your kit. It can be quickly assembled and small twigs can be collected as fuel.

The front is open and the top is open. You just get a small fire going and put your pot on top. It will boil 3 cups of water in less than 5 minutes, once the fire is going. The stove has air slots cut into the side walls which allow for excellent air flow. Also the stove bottom sits 25mm above the ground.

The box is placed on a few small stones to assist air flow and protect the ground from scorching.

While the box stove will support the weigh of a small pot it may also require a bot stand for bigger pots. Fuel tablets can also be used as a fuel source

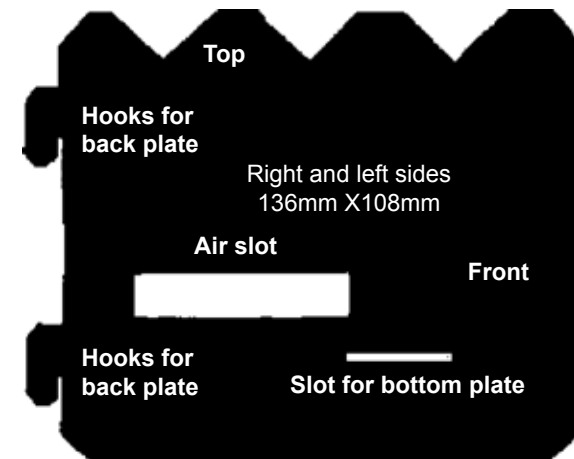
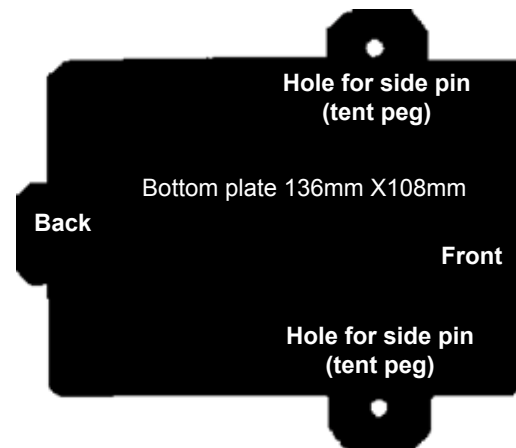
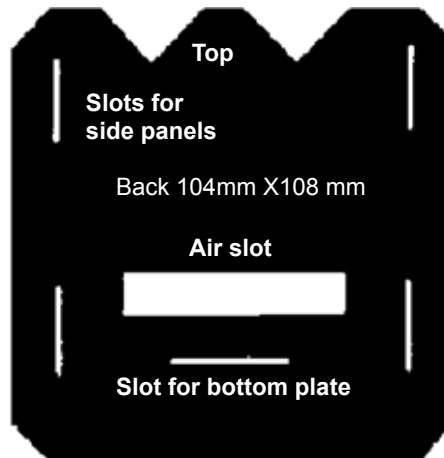
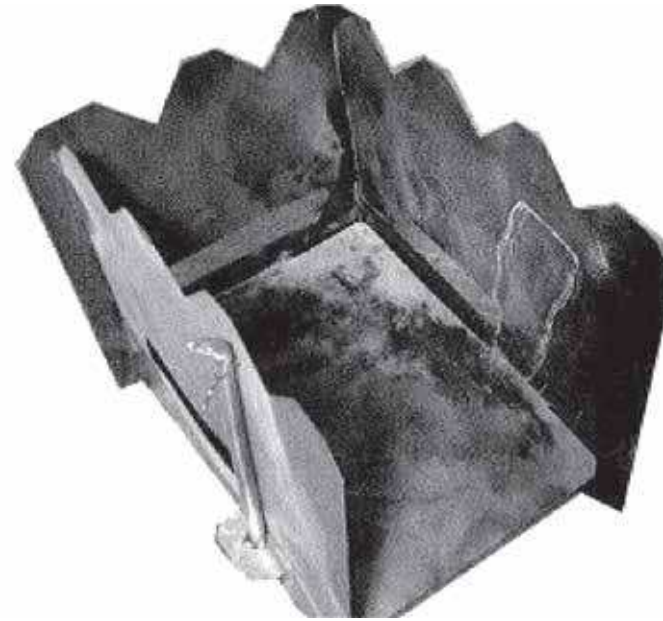

OIL CAN STOVE

Rectangular oil tins make idea stoves and mimic the traditional clay stove.

Cut out the slots and drill air holes along the base and sides of the container.

The pouring opening will be used as a small chimney and to introduce 'draw' into the container as fuel burns.

The mechanics of this stove with the wide feeder and slots for the pots create a very hot stove. Air is quickly drawn into the fire box and the small opening 'chimney' at the rear pulls the flame into the box and aids combustion.

This stove is best used in a camping situation, perhaps with a covering of earth, rather than as a backpacking stove due to its size and inability to collapse to a smaller size.



Remove lid of can to make a chimney



Cooking Oil tins (1 Gallon tins/4 liters)

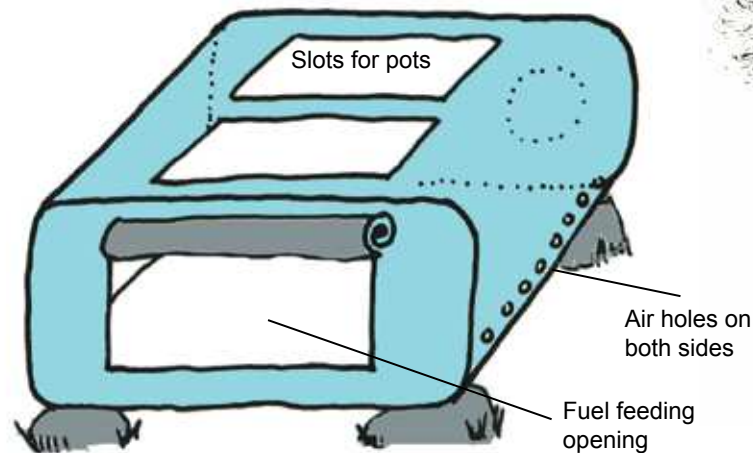

Place on small stones to protect ground

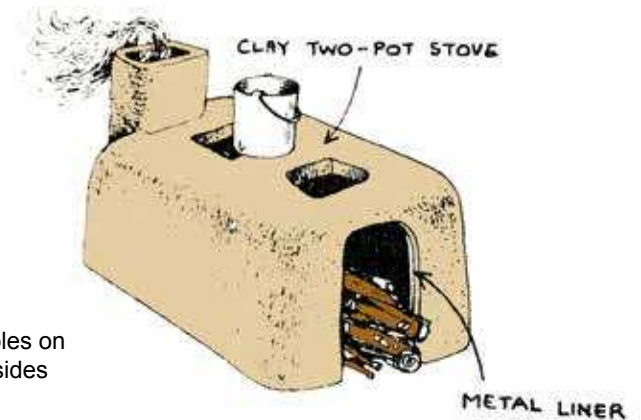

CLAY TWO-POT STOVE

METAL LINER

SIEGE MULTI PURPOSE FRAME

MAKE A SURVIVAL STOVE IN UNDER 2 MINUTES

WITH AN EMPTY CAN & SIEGE STOVE CROSS-MEMBERS

① CREATE:

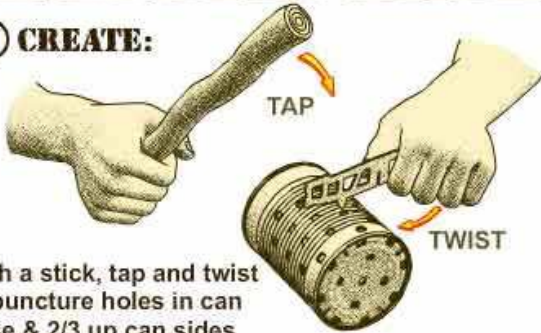

With a stick, tap and twist to puncture holes in can base & 2/3 up can sides for air flow & hotter fire.

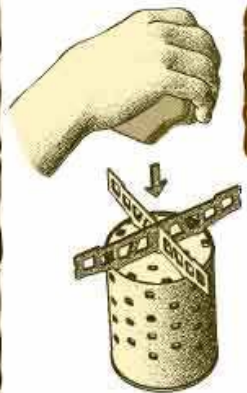

Cross-Member with sharpened fang tips

Use a stick or rock to tap the bottom Cross-Members into the can base

② ASSEMBLE:

INTERLOCK TOP AND BOTTOM CROSS-MEMBERS

PRESS CROSS-MEMBERS ONTO CAN

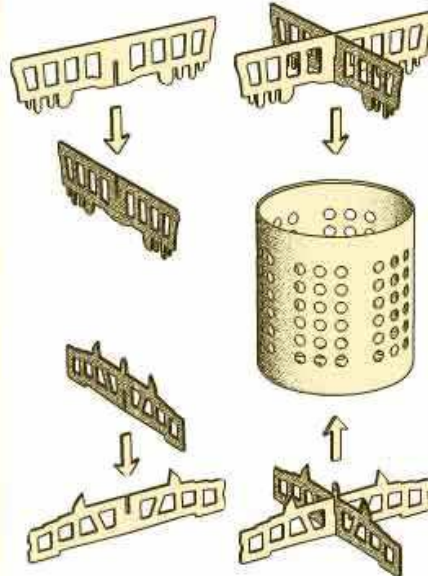

SIEGESTOVES.COM



The slots cut in the top cross members are spaced to match the dimensions of various sized cans. The piercing points are tapped into the bottom of the tin.

The cross members can be bought as a set from the siege stove site in nice shiny stainless steel but with some basic metal work skills they can be easily created in your garden shed as a low cost project.



METHS BURNER

Meths burners are used in the catering industry to keep food trays warm. The burner has also been adapted as a vital part of the Trangia stove. The Trangia stove is a key piece of scouting equipment, it provides a stable and sturdy container for cooking, pots fitting into its frame. The complete Trangia stove is a slightly heavy and bulky bit of equipment and not suited to lightweight backpacking as such. However, the key component of the stove - the burner - is a lightweight item that can, with the combination of a pot stand, a useful lightweight camp stove.

Trangia burners are relatively cheap to buy and catering meths burners are usually a bit cheaper - check out some of the online shops and our own scout shop.

The burner uses Methylated spirit which burns with a blow flame. This fuel is easy to obtain in camping shops and local chemists also carry supplies.

A fill of the fuel reservoir will provide heat for approx. 40 mins - enough to cook a full meal. The screw top cover will seal in unused fuel for the next time use. Fuel is generally carried in a fuel bottle.



Multi purpose pot stand that will fit on top of a meths burner



Alcohol burner

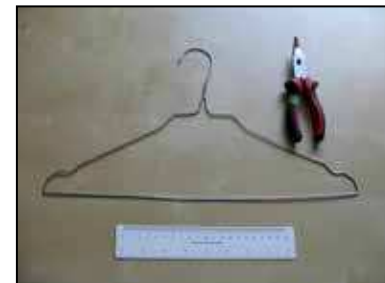

COKE TIN STOVE



Mark the cut line on the can with a marker



Cut off bottom of can with a craft knife



Place some cotton wool or fibre glass matting in the can



Place second can on top and squeeze them together



With a small nail punch a collection of holes equally placed around the rim



Also pierce 4 holes in the centre of the top as shown.



Simple alcohol burner

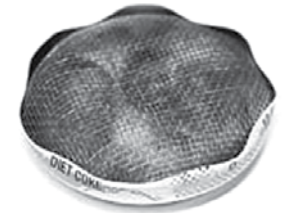

Wire mesh

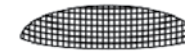

Fibre Glass matting



Bottom of a drinks can

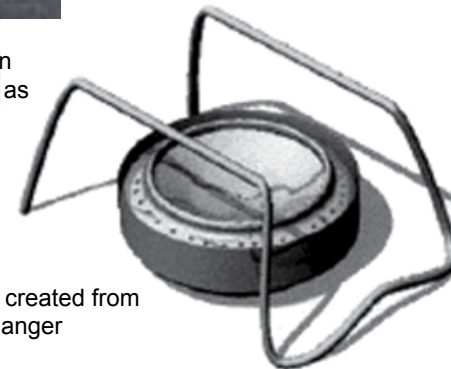
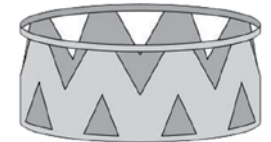

Pot stand created from old coat hanger

TABLET STOVE

Tablet stoves are cheap heating stoves that use fuel tablets as fuel. Esbit stoves are a common folding variety. The stoves are simple in design and easy to use, however they are more designed for reheating ration packs rather than cooking a meal from scratch. The stoves were designed for military use - light, reliable and easy to carry. They are good for heating up enough water for a cup of tea.



The basic frame can be modified using some light aluminum or a piece of a tin can to create a firebox so the stove can be used as a wood burner. Two panels are required one for the back and a one for the front. This makes a windproof box and aids in the burning of fuel. Check out the video via the qr code opposite.

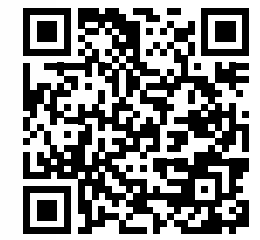

MINT TIN STOVE

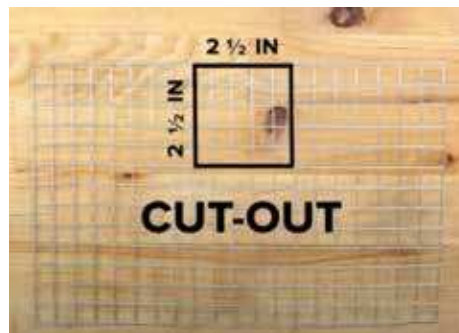

You will need some wire mesh to hold the fuel in place. Cut a section that will fit into your tin

If you are burning twigs remove the mesh to make a bigger fire box.

Small mint tins make idea containers for a stove. They are more suited to simple cooking, warming up food and quick drinks along the trail. The fuel can be alcohol, fuel tablets, waxed cardboard or twigs



Start by punching or drilling a number of air holes in the side of the tin. You then need to make 4 holes in the bottom of the tin for the support bolts. Fix the bolts to the tin as shown.



RUSSIAN HEX STOVE

Similar to the Esbit tablet stove but simpler in design - this is a Russian army ration pack cooker.

The older design is easy to make with some light tin or metal - a square with some slots cut on each side. This allows the metal plate to be bent into shape. The improved version provides a more stable stand and wind breaker plus some extra air holes to aid combustion.

The Hex stand design could be used with other stoves, such as the coke can stove, as a pot stand with some modifications.

Tablet burner

100mm

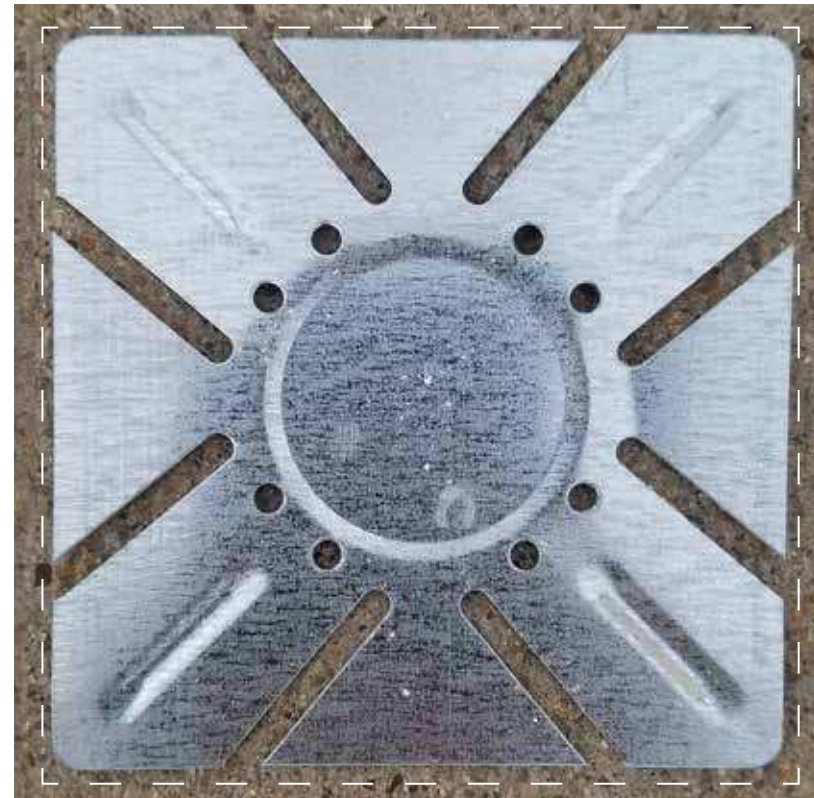

100mm



WW2 RATION STOVE



This is another ration stove, issued to Commandos during the Second world war, that can easily be made with a tin can or scraps of metal. The stove is comprised of 4 parts - a fuel base plate that is slotted into three pot supports. The pot supports are bent so that they can fit inside of the tin which also contains a number of fuel tablets. The circle fuel platform fits inside of the lid.

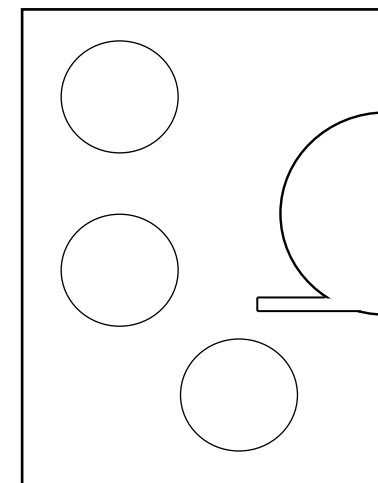
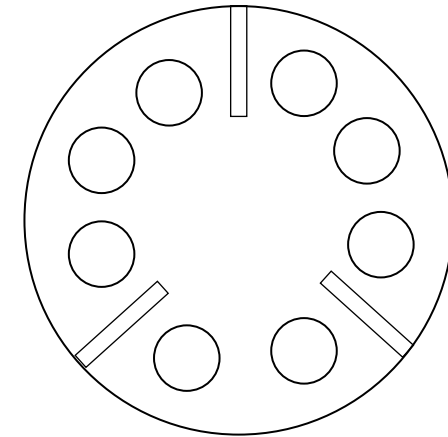

3 no. pot supports bent in a curve so they can fit inside a small tin.



A tiny ration stove issued to US marines during WW2. Again this is easy to create using metal from a tin can, a drill and a rivet.

CARDBOARD STOVE

Wax burner



To make this stove you need some corrugated cardboard, a small fruit or bean can, a craft knife and some candle wax.



Measure the inside of the tin and cut the cardboard into strips to this size.



Place a large piece (to act as a wick starter) and roll the cardboard around this. Adding strips till you create a roll that will fit tightly into the can.



Melt some old candle ends and stubs and pour the wax into the tin filling up all the holes.



Create a pot holder from some wire mesh.

SUPPORT STANDS



John McCann stove - stabilisation frames

All stoves need to have stabilisation stands to ensure that pots have a firm base to stand on and will not topple over. The designs are limitless - here are two designs that require some metal work skills but result in an excellent solution and the stabilisers are light and easy to carry.



Take a bit of care when cutting the joining slots - they need to be cut at an angle so that the parts fit together snugly.



John has approached his design from an engineering background and has produced an excellent solution. Start firstly by making a paper template, then use this template to mark up the cutting lines. The holes on each of the frames reduce the weight of each piece. Check out his template designs on the next page and visit his website for construction guidelines

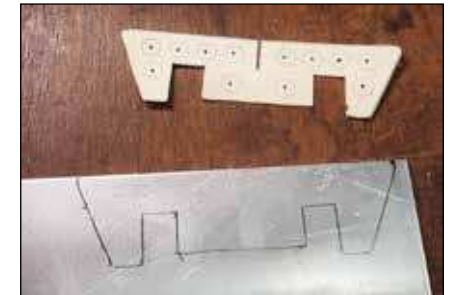

Pot stand

Trangia Alcohol Stove Pot Support

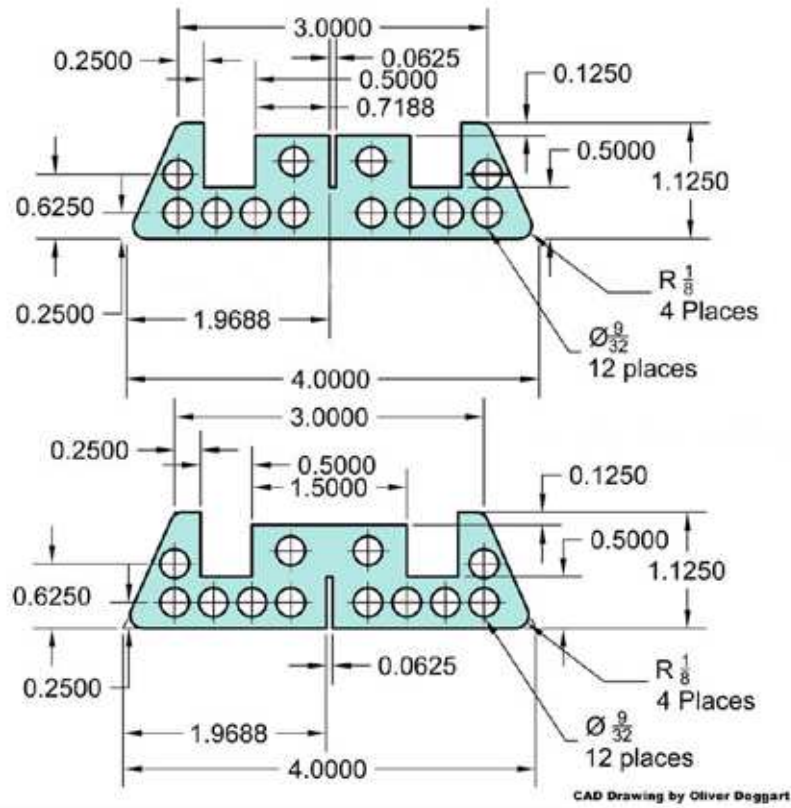

John McCann stove - stabilisation frames

Trangia Alcohol Stove Stand

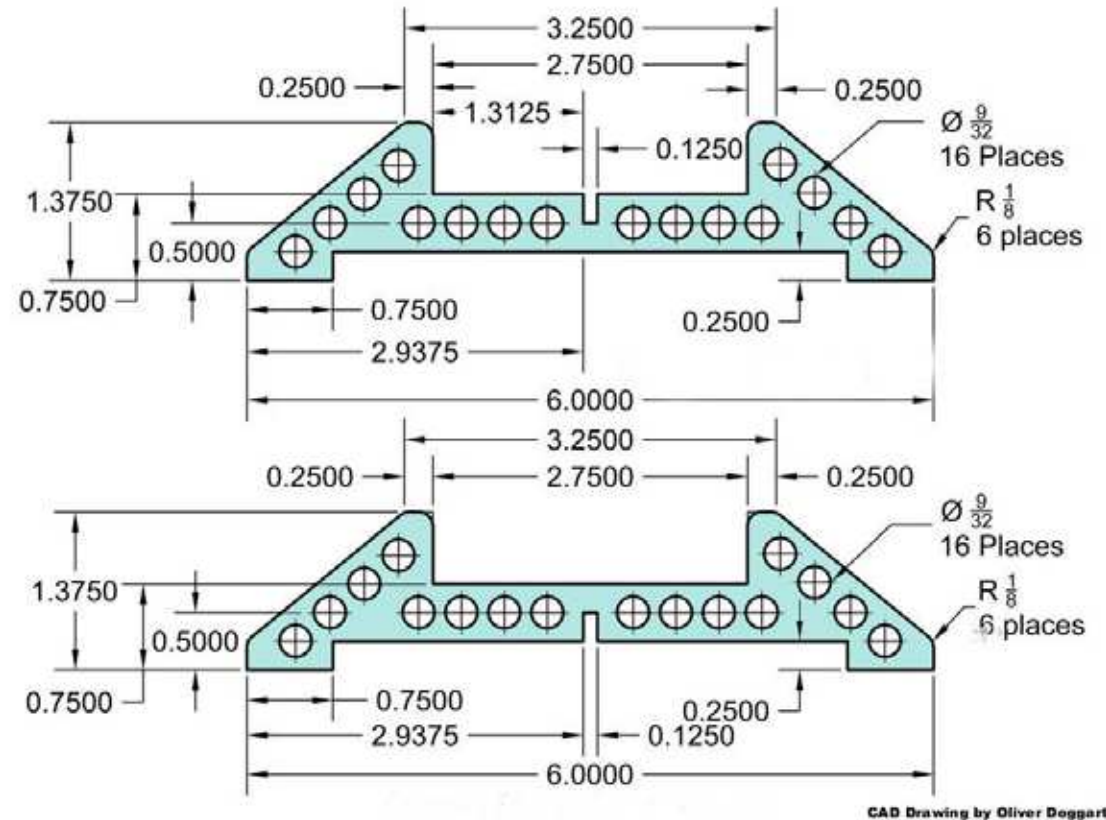

Drawings are not to scale and are in inches.

Construction instructions



TENT PEG AND WIRE STANDS

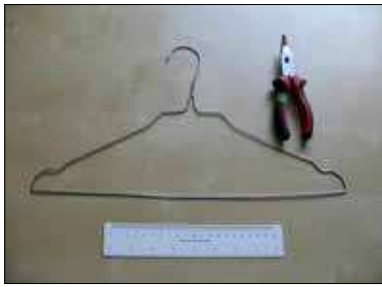

This frame can be clipped around a pot or container to save space.



Two wire frames joined by a simple wire joint that allows the frame to be folded flat.



This frame uses a small metal tube to provide the hinge for the frames

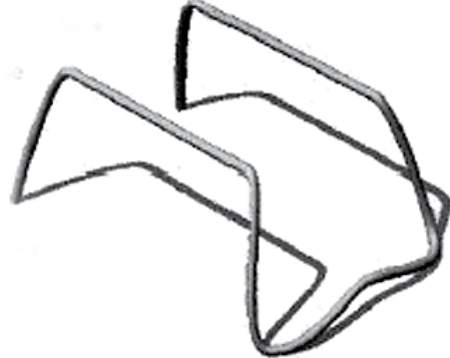

ROCKET STOVES

The rocket stove is a tube based stove that exploits the fundamental feature of a fireplace or cooking stove requiring a chimney. The draught created within the tube draws the fire and heat into the tube and releases the smoke and fumes up the chimney.

Rocket stove combustion systems deserve attention for a few reasons:

- they offer close to complete combustion of the wood, meaning they are hyper-efficient and burn super-clean
- they can reach very high temperatures, and can be hooked up to almost anything we want to use that heat for
- they can use wood typically considered too small to call firewood
- they are easily built from common materials.

THE FUNDAMENTALS OF A BASIC J-STYLE ROCKET STOVE BURN UNIT

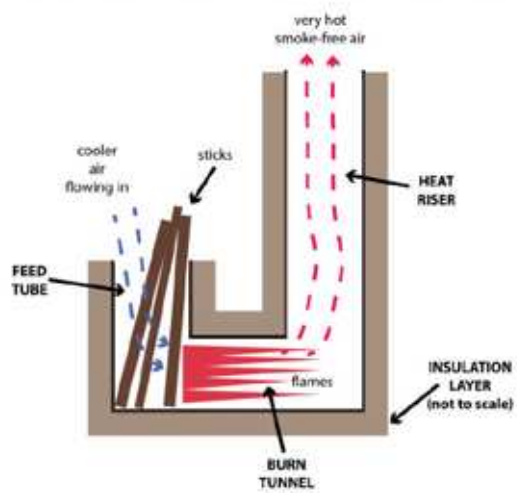

Very simple rocket stove using a metal bucket



Firstly you need a selection of cans

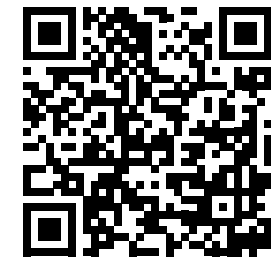

Mark out a hole in the big can and cut out a hole so that the 'feeder can' (small sized can) will slot in tightly.



Cut a slot in the 'funnel can' (medium sized can) so that it will fit over the 'feeder' can when placed inside the larger can. Then cut off the base of the tin to create a funnel.



Lastly, place clay and loose stones around the inner funnel to the level of the funnel can. to act as an insulating layer. Cut slots on the bigger can to allow air flow under the pot and you are good to go.

OIL DRUMS FIRES AND OVENS

In a camp situation oil drums and cans can be re purposed to create more efficient stove and cookers. Containers also protect the ground from burning and if used in a clever way can be fashioned into reflective oven to allow the possibilities of other recipes to be tried. Scones, bread, cakes, roasting of meats.

Coat hangers, piece of wire, nails and tent pegs can also be used to create grills and supports.

Traditionally, Scouts also created camp ovens by placing a tin box on the ground and surrounding the box with clay to hold in and insulate the heat in the box.

Cardboard box ovens are also a favorite alternative using bar-b-que coals and nuggets as the heating source.

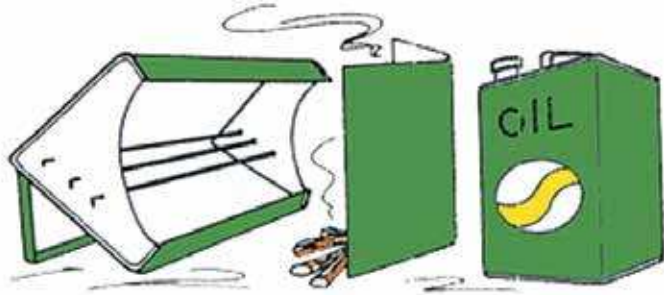

Reflector oven

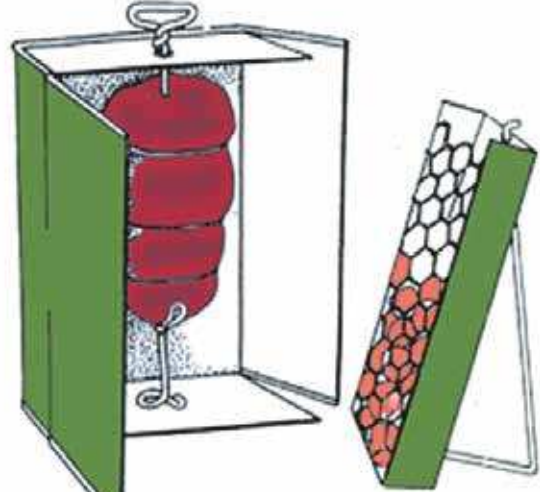

Roasting spit

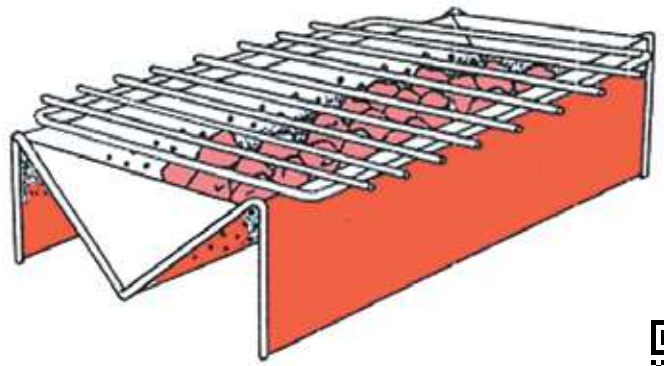

Bar-b-que box

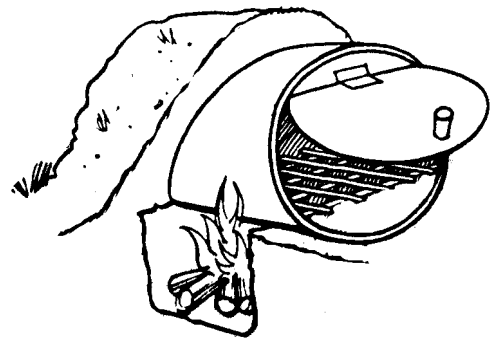
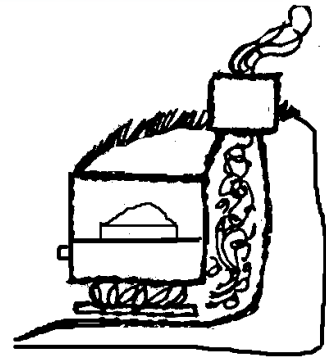

The fire pit and chimney work similar to a rocket stove - air is drawn up the chimney and this in turn draws the flames across the fire box and around the tin oven.