

FUN BOATS

Easy to construct boats and canoes for fun water activities



 **SCOUTING
IRELAND**
**BEGIN
ADVENTURES
HERE**

ON THE WATER FUN

This resource provides some fun boat building ideas to try during the coming months.

Most of the boats can be built with easy to find materials - cardboard and some duct tape.

We also present a more ambitious suggestion of constructing a traditional coracle and a canvas covered canoe in the Inuit Greenland tradition that will appeal as project for a Patrol or Venture Scout unit.

The nature of these suggestions are experimental. Scouts will get wet and some boats may fall apart if not constructed with care. Learning by doing is a key principle to keep in mind. Scouts will learn how to craft and cut materials to size and with care. Taping the seams will be really important to prevent leaks and the possibility that your boat may sink or fall apart.

All boats will need testing and refining of design, some will be stable while others rely on weight positioning to prevent rollover - these are things to be explored.

The activity should take place in shallow water, and all water safety measures employed - life jackets, bouyance aids and buddy system.

To add to the challenge a boat race or trials adds to the activity. Cardboard boat building and racing is a popular activity in many places - particularly with engineering and design students - but why should they have all the fun.

While it is possible to build good boats from just using and recycling packaging boxes it is often better to get 'clean' sheets from a packaging supplier. These sheets come without folds and aid in strengthening the boat design. Check out the web for suppliers. Local printing companies may also be able to direct you to a supplier.

Large appliance stores often remove and recycle packaging and they may also be a good source.

Building supply stores also carry floor protection sheets which are made of thin plastic cardboard. While they are often a bit thin to provide the rigidity to make a boat from them alone, they do make ideal waterproof outer sheets and are relatively cheap to buy. They would be wrapped around the outer cardboard shell.

The suggested designs should be used as a starting point. Scouts should be encouraged to experiment and modify designs, maybe even create a new design.

Activity leaders should be aware of the use of tools and make sure they are used in a safe manner. Supervision is helpful - but do not have adults making these boats **LET THE SCOUTS DO IT!!**

Opposite are the rules of a cardboard boat competition for reference if you wish to create such an event in your section or group.



Cardboard Boat Challenge

To design and build a boat using only cardboard and duct tape that will successfully carry two passengers across a swimming pool in the least amount of time.

The **ENTIRE BOAT** must be **BUILT ONLY OF CARDBOARD** and duct tape.

- The cardboard should be standard heavy duty cardboard typically used to package appliances or supplies. (The emphasis is on the fun-filled process of turning discarded cardboard boxes into floating boats.)
- The propulsion system, including oars and paddles, must be made from regular cardboard only!!
- Please ensure that the 2 members in the boat know how to swim, and are wearing approved and properly fitted personal flotation devices (PFD). Lifeguards should be on duty.
- Consider "staying dry" as part of the challenge.
- Boats will be launched from the side of the pool at the start of the event.
- Duct Tape is only allowed to assemble and reinforce seams. It is not allowed to wrap, encase or waterproof the boat.

BOAT FUN & WATER SAFETY

Activity on water is always great fun, however care needs to be taken at all times to prevent injury. Open water, such as lakes, rivers and sea can be dangerous.

First and foremost you need to be able to swim. If you don't know how to swim then join a swimming class and learn.

For most boating activities, it is advisable that you can swim a distance of at least 50 metres, and stay afloat for 2 minutes without the aid of a lifejacket.

Always make sure you wear a lifejacket or buoyancy aid as appropriate on all water based activities, even if the water is shallow.

Open water is always cold. Water is a heat conductor and will draw heat away from your body very quickly. Wind chill also plays a big part in the cooling down process. For this reason it is advisable to wear the right clothing when taking part in water activities. Along with your life jacket you will need to wear a wind proof jacket, a tee shirt or light fleece and old training shoes with warm dry clothes available to change into after the activity.

You will get wet, but be careful not to get cold. If you feel you are getting too cold or are shivering, tell the activity leader. Work the Buddy system and keep an eye on each other.



Wet or dry suit
Booties



Wind proof
jacket



Helmet for
protection



Bouyancy Jacket



Buddy system

In all Scouting water activities we use the Buddy system for safety. Each Scout is asked to team up with another Scout while taking part. Your job as a Buddy is to look out for your partner and he/she has to look out for you. If you are a Patrol Leader you will have the additional responsibility of looking out for all the members of your Patrol. From time to time the activity leader will call for 'Buddies'. At the signal you should find your Buddy - who should be close by, and hold his/her hand out of the water so that you can be clearly seen. Once everyone is checked you can resume your enjoyment. Its a simple idea that everyone can understand, a simple idea that can save a life.



CARDBOARD BOAT 1

This is a folded cardboard boat design. It is comprised of two sections - an inner and outer shell.

To create the boat you will need some large sized cardboard sheets that have to be cut out as outlined on the next page.

A series of folds are worked into the cardboard to create the desired shape.

Once the outer shell is created the inner section is placed inside to create a ridge canoe. All joints are sealed with duck tape and a protective seal can be applied to the outer shell to preserve the waterproof the outside of the boat.



<http://cardboat.blogspot.com/2012/08/how-to-build-cardboat.html>



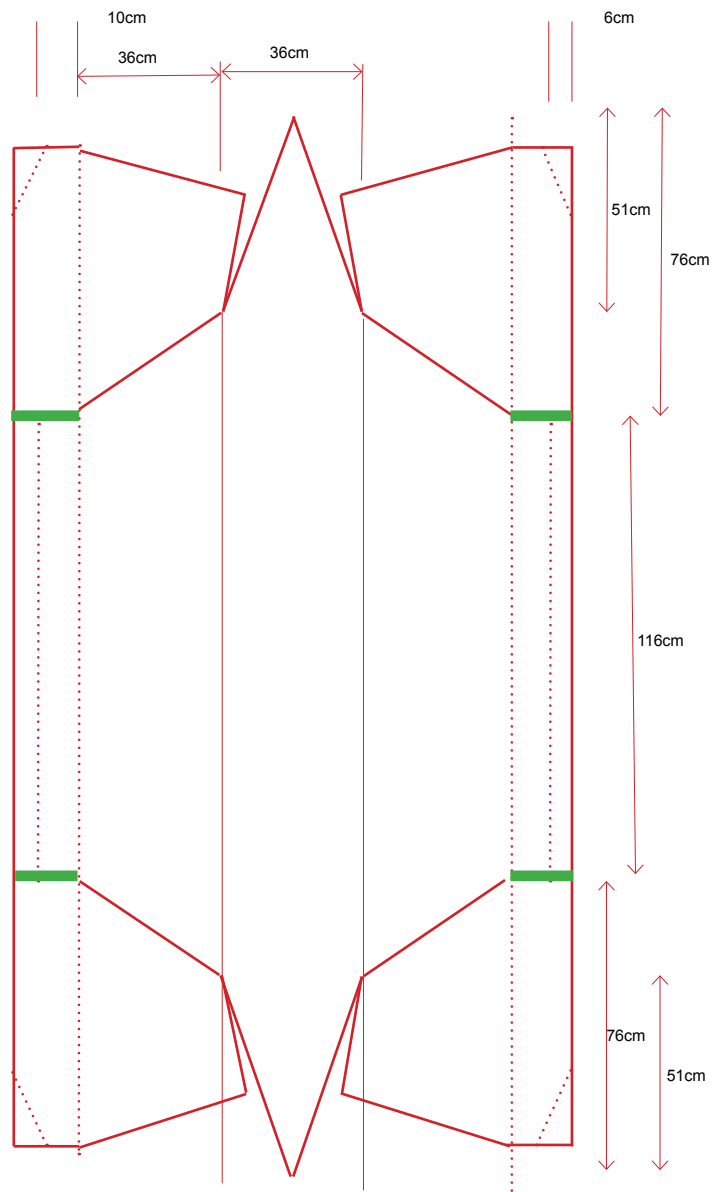

— Fold Reverse fold
 — Cut Canoe insert

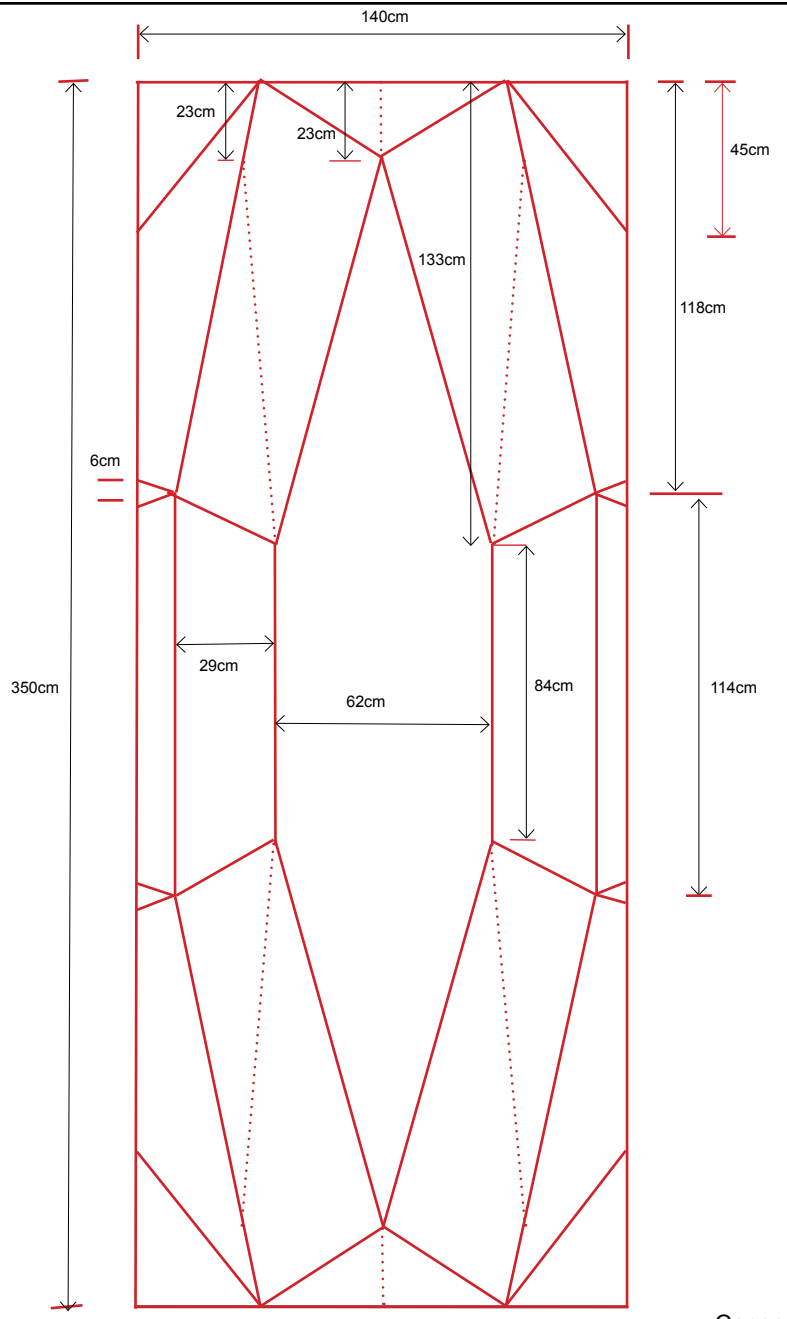

— Fold Reverse fold Canoe outer skin



CARDBOARD BOAT 2

Cardboard boats - that don't sink!! This design enables the construction of a stable and water resistant cardboard boat. To construct the frame requires some layout, planning and cutting skills. Once the pieces are created they slot together to form the boat frame. The frame is then covered with cardboard. All the joints are sealed with duct tape. The outside can also be painted to make it more water tight or an outer plastic 'cardboard' layer can be placed over the basic cardboard boat.

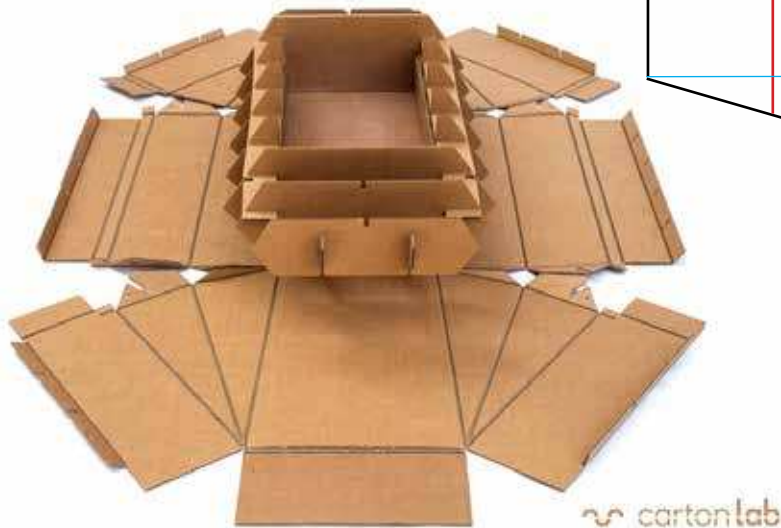
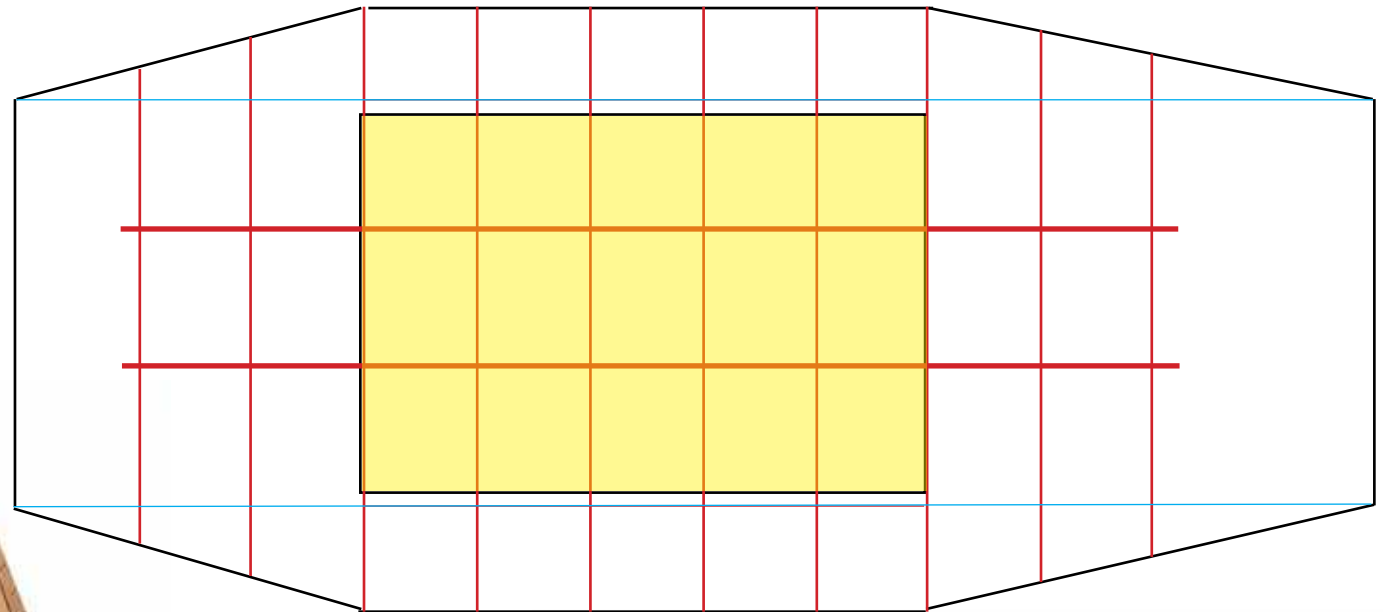
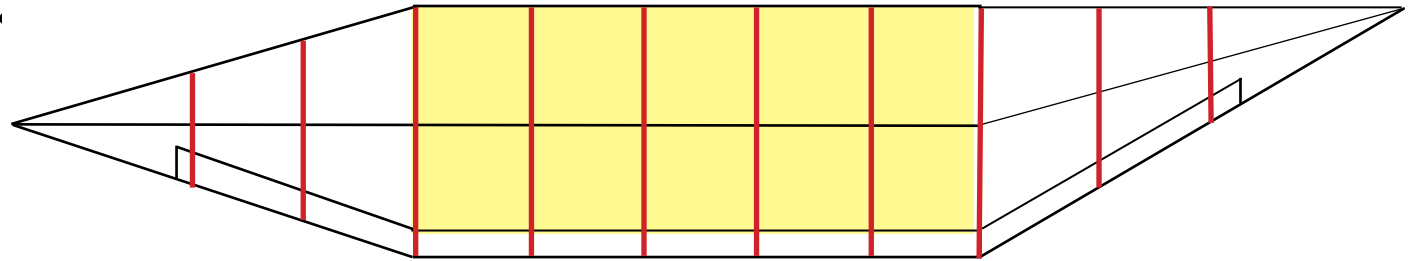

These boats are fun projects. They are used in safe waters, and ponds. While they have a solid structure they also have a short lifespan once water enters the cardboard frame.



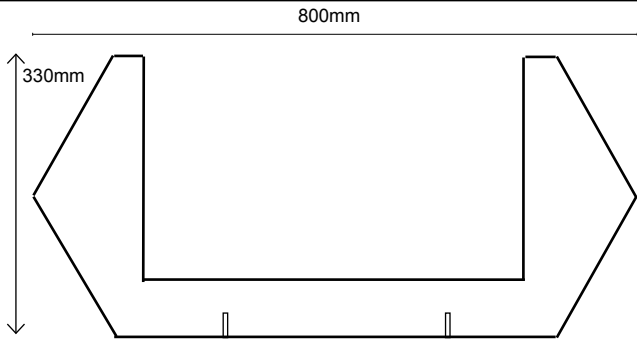

4 no box side wall supports

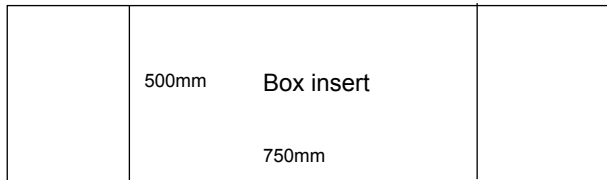

Box insert

750mm

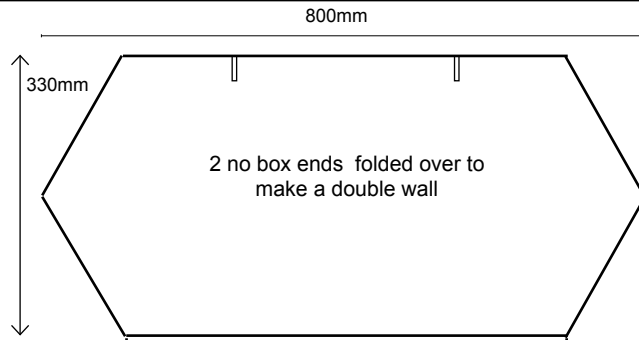

2 no box ends folded over to make a double wall

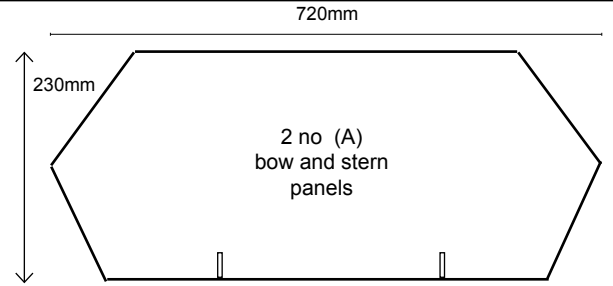
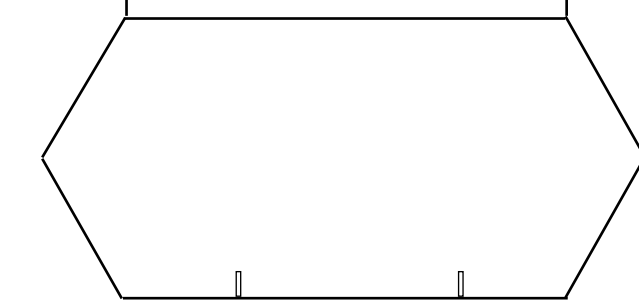

2 no (A) bow and stern panels

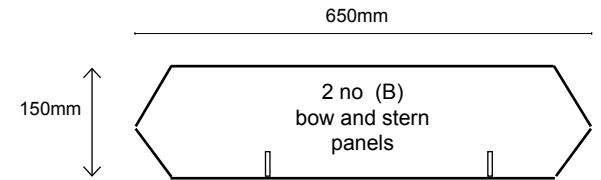

2 no (B) bow and stern panels

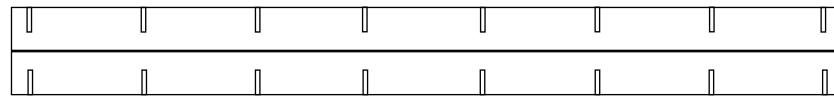

2.no folded in half to act as gunnels

1090mm

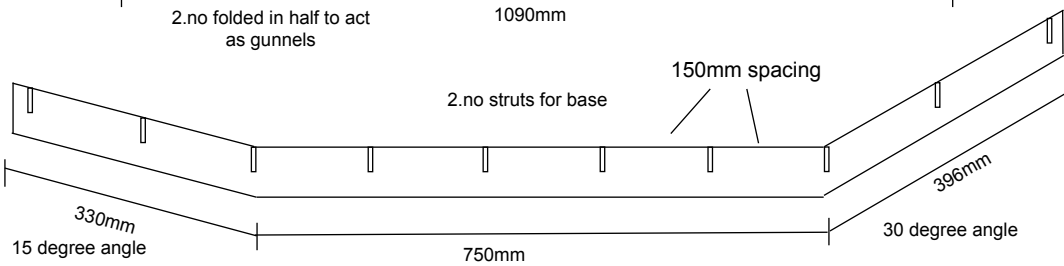

2.no struts for base

150mm spacing

396mm

330mm

15 degree angle

750mm

30 degree angle



Sheet cardboard can be obtained from large appliance packing. Sheets can also be obtained from packaging suppliers. Check it out on line.

Plastic cardboard sheeting can be obtained in building suppliers. It is used as a floor protector. It is light and easy to work with and can form an outer water proof layer for your boat. All joints need to be sealed with duct tape.

Measurements should be used as a guide. It will be necessary to adapt frames as you construct the boat and fix the other layer of cardboard.



PLASTIC WRAP CANOE

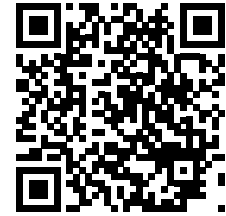

1.



3.



5.



7.



2.



4.



6.



8.

CORACLE

The Coracle - traditional water craft

The coracle is a traditional water craft used for centuries by river men fishing salmon. It was particularly popular on the Boyne where the last known coracle was used. It is an excellent and fun filled activity for Scouts and its backward element certainly makes it a scouting skill worth possessing. They can be simply built in one day or two days if you want a more permanent craft.



The picture shows traditional Welsh coracle circa 1890. This craft is built using ash lathes and covered with cowhide.



The coracle is paddled by leaning over the edge of the craft as shown and using a drawing stroke in a 'S' movement. This may feel strange at first but is the best method of propelling the craft.

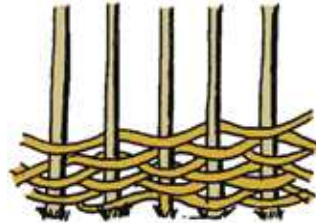

An interlacing binding is woven around the base of the rods before the frame is removed from the ground. These needs to be about 100mm deep and constructed using light willow or hazel rods

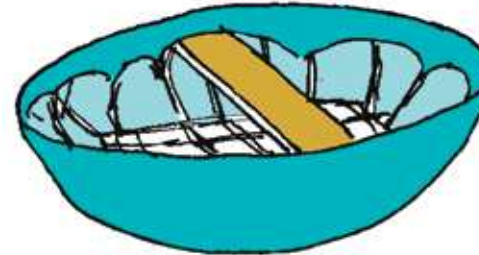

The coracle is created by making a frame and then covering it with a tarpaulin sheet or heavy plastic sheet which is stretched over the frame and secured to the inside of the craft.

The frame of the coracle is constructed using 32 hazel or ash rods about 25mm in diameter. The rods are pushed into the ground to create a 2 metre by 1.5 metre frame. The idea is to create a basket about 50cm high. When the frame is created place rocks or a heavy weight on top of the frame to keep it in shape over night.

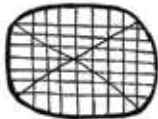

Bend over the rods to create a basket shape. The rods need to be tied together first before trimming the overlap. Don't trim straight away but rather wait until the frame is correctly shaped. The trimming needs to be done carefully so that their are no burrs that may damage the skin of the craft

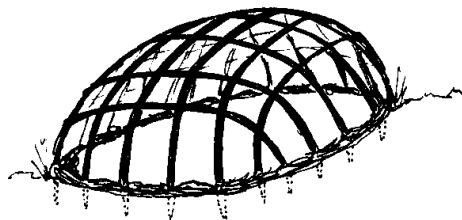

When the frame is complete check it for any sharp edges. Trim these and sand down if necessary. Place a simple lashing at each intersection of the frame, this helps to hold it together. When you are happy cut the frame away from the ground rather than pull it out of the ground. This action prevents the frame from being damaged. Secure the interlacing binding and fix in the seat. Be happy that the frame is sound before drawing on the over sheeting.

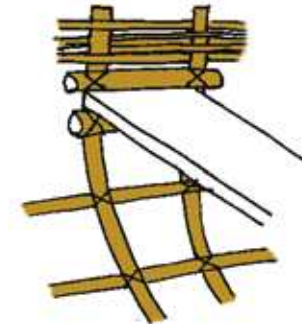

Seat Detail
The seat should be fixed against the frame of the craft and secured by a top and bottom brace.

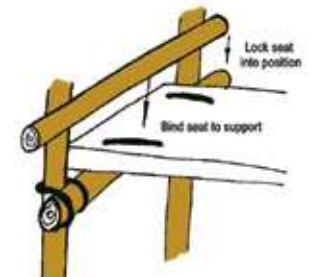

RUBBER TUBE BOATS

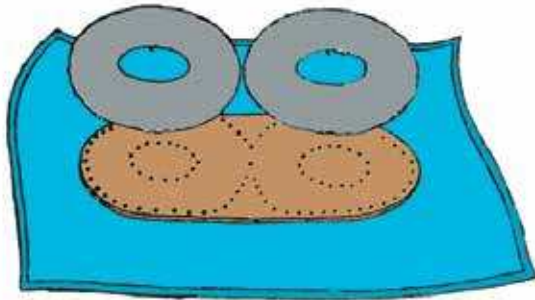

Inner tyre tubes provide instant buoyancy and are ideal for the creation of simple rafts and boats.

A baseboard is cut from ply sheeting and the inner tubes are laced onto the board. A plastic tarp sheet is then used to cover the base and tubes and it is ready for use.

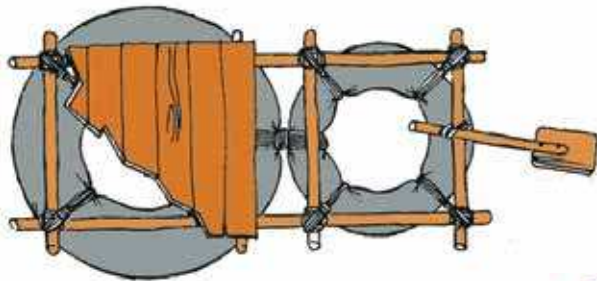

This design uses a simple lashed frame to provide stability. The tubes are lashed to the frame. This design also shows a simple rudder to add maneuvers on water.



A bigger challenge...this raft/boat requires a number of large tubes and a solid frame. A simple sail structure is also used. This mast is placed in a solid board that is lashed to the frame and guy ropes keep the mast upright.

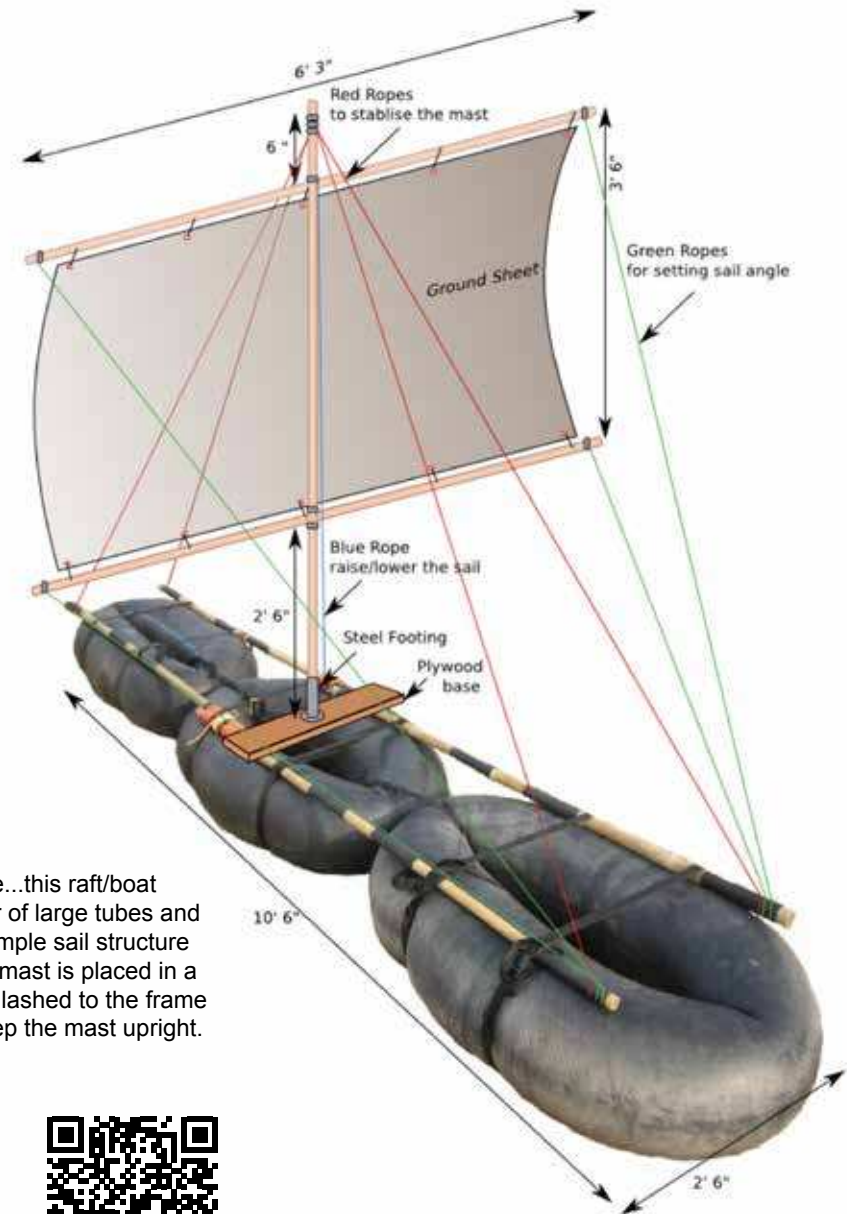

ORIGAMI BOAT DESIGN

This is a design concept boat that could be used for disaster relief. Its design is simple and with minimal skills the sheet can be folded and secured to create a boat shape.

The whole piece consists of the main body and two paddles. It is constructed of 'Corriboard' a plastic cardboard which is flexible and durable.

The paddles are separated from the main sheet and the sheet is folded according to the creases.

When folded to shape, the frame of the boat is kept in shape by threading a short piece of rope through the holes at the top and bottom of the sheet.



CANOE MAKING FOR THE MORE AMBITIOUS

This canoe construction is an idea project for a Venture Section or a Patrol with supervision. It requires some basic woodworking skills. Detailed instruction methods can be observed on the video links

